

SANYO	No. ※4965	LC75741E, 75741W
1/2 Duty VFD Driver for Frequency Displays		

Preliminary

Overview

The LC75741E and LC75741W are 1/2 duty VFD drivers for use in electronic tuning frequency displays controlled by a microcontroller. These products can directly drive VFD displays with up to 106 segments.

Functions and Features

- 106 segment outputs
- Noise reduction circuit built into the output drivers.
- Display and dimmer data communication with the controller using the C²B* format.
- High generality, since display data is displayed directly without decoder intervention
- All segments can be turned off with the BLK pins.
- Package: QFP64E (LC75741E)
SQFP64 (LC75741W)

Note: * C²B is Sanyo's original bus format with address management for all Sanyo products.

Package Dimensions

unit: mm

3159-QFP64E

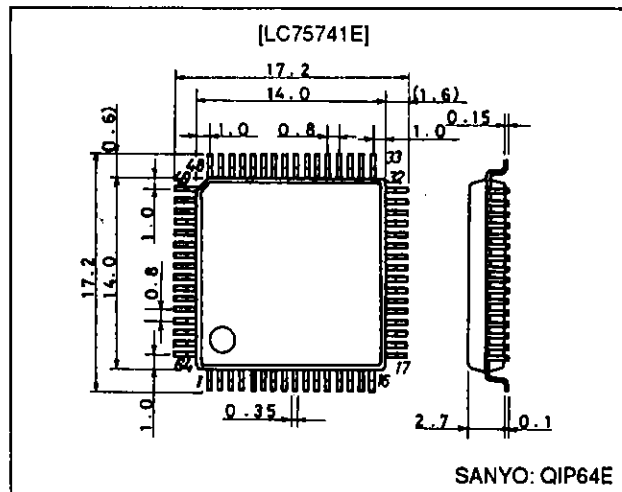

unit: mm

3190-SQFP64

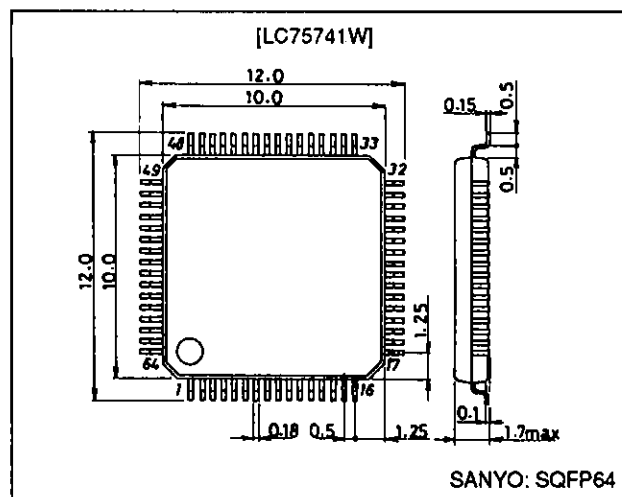

Specifications

Absolute Maximum Ratings at $T_a = 25^\circ\text{C}$, $V_{SS} = 0\text{ V}$

Parameter	Symbol	Conditions	Ratings	Unit
Maximum supply voltage	$V_{DD\text{ max}}$	V_{DD}	-0.3 to +6.5	V
	$V_{FL\text{ max}}$	V_{FL}	-0.3 to +21.0	V
Input voltage	V_{IN1}	DI, CL, CE, $\overline{\text{BLK}}$	-0.3 to +6.5	V
	V_{IN2}	OSCI	-0.3 to $V_{DD} + 0.3$	V
Output voltage	V_{OUT1}	S1 to S53, G1, G2	-0.3 to $V_{FL} + 0.3$	V
	V_{OUT2}	OSCO	-0.3 to $V_{DD} + 0.3$	V
Output current	I_{OUT1}	S1 to S53	5	mA
	I_{OUT2}	G1, G2	60	mA
Allowable power dissipation	$P_d\text{ max}$	$T_a = 85^\circ\text{C}$	400 (LC75741E)	mW
			300 (LC75741W)	mW
Operating temperature	T_{opr}		-40 to +85	$^\circ\text{C}$
Storage temperature	T_{stg}		-50 to +150	$^\circ\text{C}$

Allowable Operating Ranges at $T_a = -40$ to $+85^\circ\text{C}$, $V_{DD} = 4.5$ to 5.5 V , $V_{SS} = 0\text{ V}$

Parameter	Symbol	Conditions	min	typ	max	Unit
Supply voltage	V_{DD}	V_{DD}	4.5	5.0	5.5	V
	V_{FL}	V_{FL}	8	12	18	V
Input high level voltage	V_{IH1}	DI, CL, CE, $\overline{\text{BLK}}$	$0.8 V_{DD}$		5.5	V
	V_{IH2}	OSCI	$0.7 V_{DD}$		V_{DD}	V
Input low level voltage	V_{IL1}	DI, CL, CE, $\overline{\text{BLK}}$	0		$0.2 V_{DD}$	V
	V_{IL2}	OSCI	0		$0.3 V_{DD}$	V
Guaranteed oscillator range	f_{OSC}	OSCI, OSCO	0.4	1.6	3.0	MHz
Recommended external resistance	R_{OSC}	OSCI, OSCO		20		k Ω
Recommended external capacitance	C_{OSC}	OSCI, OSCO		47		pF
Low level clock pulse width	t_{bL}	CL: Figure 1	0.5			μs
High level clock pulse width	t_{bH}	CL: Figure 1	0.5			μs
Data setup time	t_{ds}	DI, CL: Figure 1	0.5			μs
Data hold time	t_{dh}	DI, CL: Figure 1	0.5			μs
CE wait time	t_{cp}	CE, CL: Figure 1	0.5			μs
CE setup time	t_{cs}	CE, CL: Figure 1	0.5			μs
CE hold time	t_{ch}	CE, CL: Figure 1	0.5			μs
$\overline{\text{BLK}}$ switching time	t_c	$\overline{\text{BLK}}$, CE: Figure 3	10			μs

Electrical Characteristics in the Allowable Operating Ranges

Parameter	Symbol	Conditions	min	typ	max	Unit
Input high level current	I_{IH}	DI, CL, CE, $\overline{\text{BLK}}$, OSCI: $V_I = 5.5\text{ V}$			5	μA
Input low level current	I_{IL}	DI, CL, CE, $\overline{\text{BLK}}$, OSCI: $V_I = 0\text{ V}$	-5			μA
Output high level voltage	V_{OH1}	S1 to S53: $I_O = 2\text{ mA}$	$V_{FL} - 0.6$			V
	V_{OH2}	G1, G2: $I_O = 25\text{ mA}$	$V_{FL} - 0.6$			V
	V_{OH3}	G1, G2: $I_O = 50\text{ mA}$	$V_{FL} - 1.3$			V
	V_{OH4}	OSCO: $I_O = 0.5\text{ mA}$	$V_{DD} - 2.0$			V
Output low level voltage	V_{OL1}	S1 to S53, G1, G2: $I_O = -5\text{ }\mu\text{A}$, $T_a = 25^\circ\text{C}$		0.25	0.5	V
	V_{OL2}	OSCO: $I_O = -0.5\text{ mA}$			2.0	V
Oscillator frequency	f_{OSC}	$R_{OSC} = 20\text{ k}\Omega$, $C_{OSC} = 47\text{ pF}$		1.6		MHz
Hysteresis voltage	V_H	DI, CL, CE, $\overline{\text{BLK}}$		$0.1 V_{DD}$		V
Current drain	I_{DD}	Output open: $f_{OSC} = 1.6\text{ MHz}$			10	mA

1. When CL is stopped at the low level

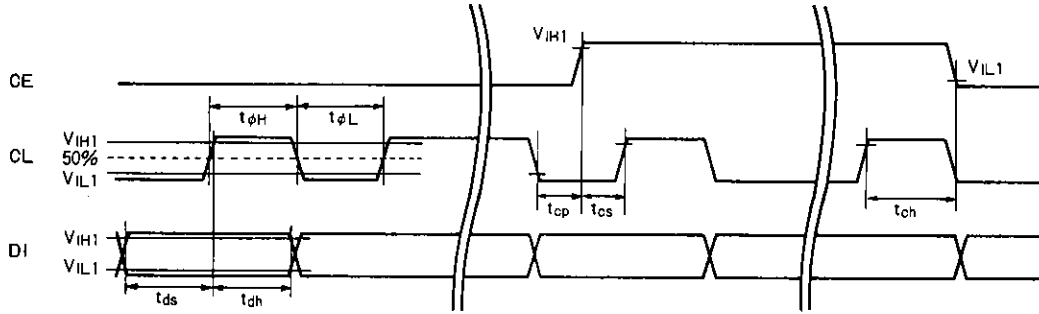

2. When CL is stopped at the high level

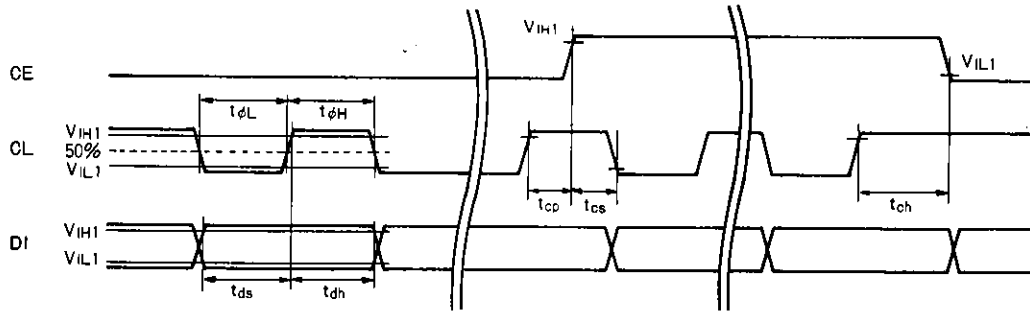
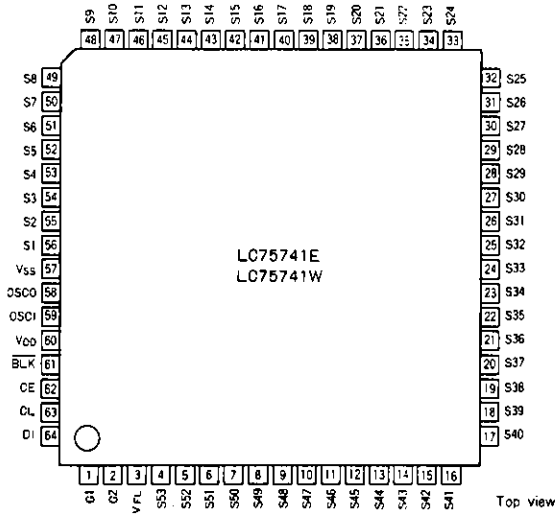
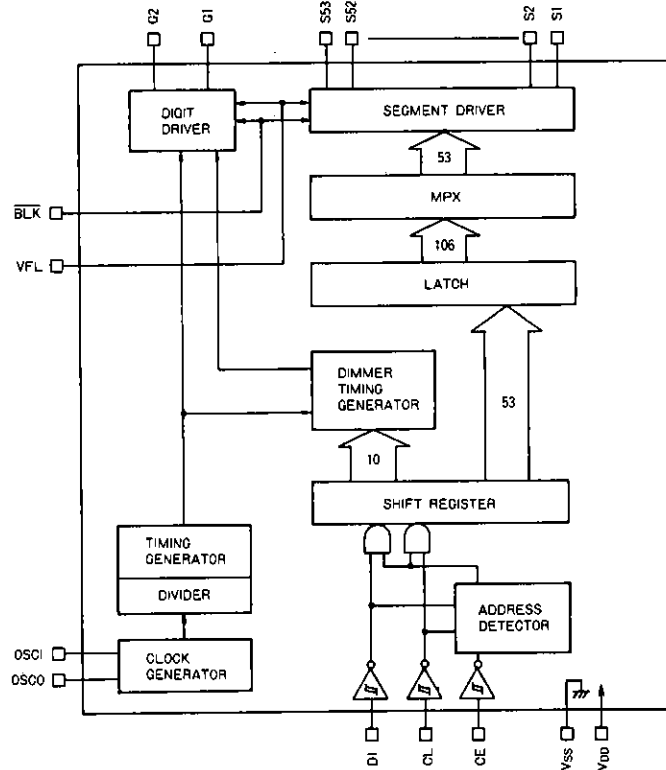

Figure 1

Pin Assignment



Block Diagram



Pin Functions

Pin	Pin No.	I/O	Function
V _{FL}	3	—	Driver block power supply. A voltage of between 8.0 and 18.0 V must be supplied.
V _{DD}	60	—	Logic block power supply. A voltage of between 4.5 and 5.5 V must be supplied.
V _{SS}	57	—	Power supply. Must be connected to ground.
OSC1, OSCO	59 58	I/O	Oscillator connections. An oscillator circuit is formed by connecting an external resistor and capacitor at these pins.
BLK	61	I	Display off control input BLK = low (V _{SS}): Display off (S1 to S53, G1 and G2 = low) BLK = high (V _{DD}): Display on Note that serial data transfers are still allowed when display is turned off using this pin.
CL	63	I	Serial data transfer inputs. Connect to the system microcontroller. CL: Synchronization clock DI: Transfer data CE: Chip enable
DI	64		
CE	62		
G1, G2	1, 2	O	Digit outputs. The frame frequency f_O is $f_{OSC}/4096$ Hz.
S1 to S53	56 to 4	O	Segment outputs for displaying the display data transferred by serial data input.

Serial Data Transfer Format

1. When CL is stopped at the low level

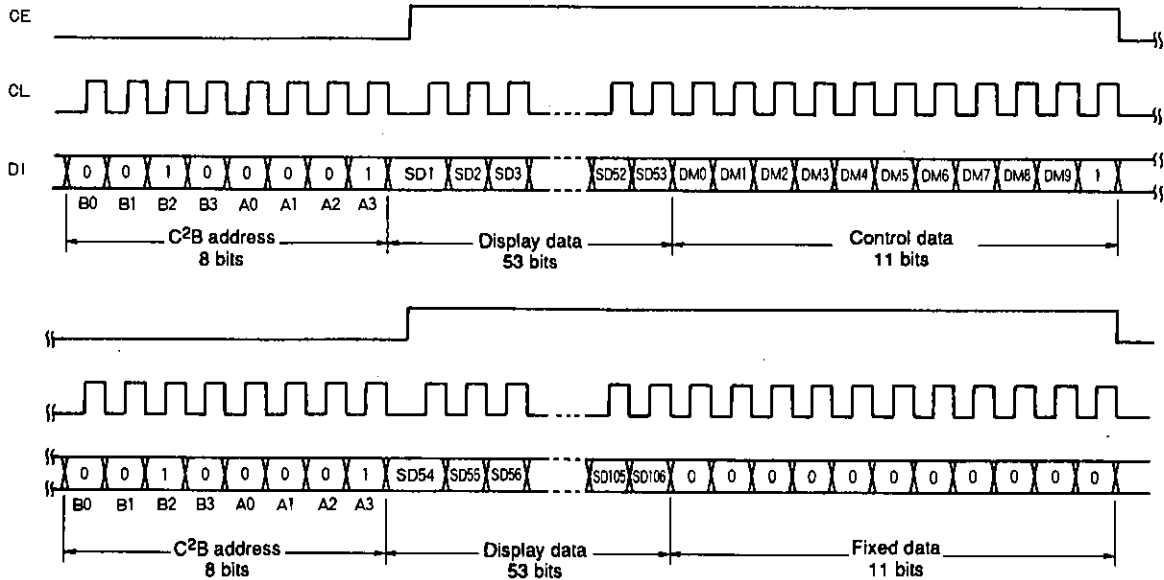

2. When CL is stopped at the high level

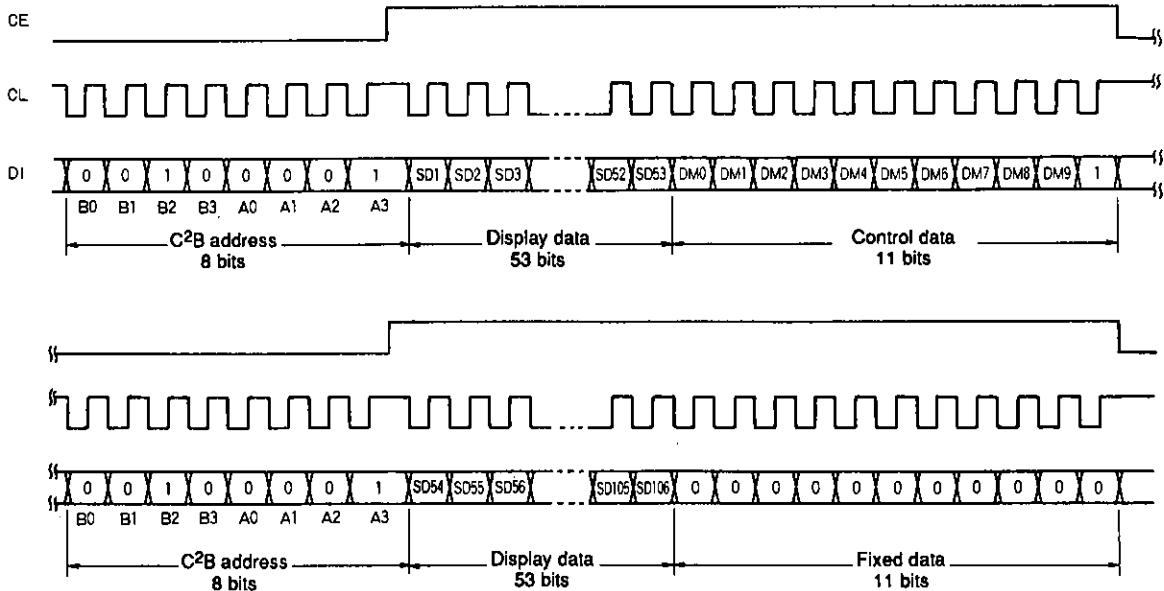

Figure 2

C²B address: Transfer 00100001_B as shown in Figure 2.

DM0 to DM9: Dimmer data

This data controls the duty of the G1 and G2 digit output pins, and consists of 10 bits with DM0 being the LSB. Note that the intensity of the display can be adjusted by controlling the duty of the G1 and G2 digit output pins.

SD1 to SD53: Display data for the G1 digit output pin.

SD_n (n = 1 to 53) = 1: On

SD_n (n = 1 to 53) = 0: Off

SD54 to SD106: Display data for the G2 digit output pin.

SD_n (n = 54 to 106) = 1: On

SD_n (n = 54 to 106) = 0: Off

Correspondence between Display Data (SD1 to SD106) and Segment Output Pins

Segment output pin	G1	G2
S1	SD1	SD54
S2	SD2	SD55
S3	SD3	SD56
S4	SD4	SD57
S5	SD5	SD58
S6	SD6	SD59
S7	SD7	SD60
S8	SD8	SD61
S9	SD9	SD62
S10	SD10	SD63
S11	SD11	SD64
S12	SD12	SD65
S13	SD13	SD66
S14	SD14	SD67
S15	SD15	SD68
S16	SD16	SD69
S17	SD17	SD70
S18	SD18	SD71
S19	SD19	SD72
S20	SD20	SD73
S21	SD21	SD74
S22	SD22	SD75
S23	SD23	SD76
S24	SD24	SD77
S25	SD25	SD78
S26	SD26	SD79
S27	SD27	SD80

Segment output pin	G1	G2
S28	SD28	SD81
S29	SD29	SD82
S30	SD30	SD83
S31	SD31	SD84
S32	SD32	SD85
S33	SD33	SD86
S34	SD34	SD87
S35	SD35	SD88
S36	SD36	SD89
S37	SD37	SD90
S38	SD38	SD91
S39	SD39	SD92
S40	SD40	SD93
S41	SD41	SD94
S42	SD42	SD95
S43	SD43	SD96
S44	SD44	SD97
S45	SD45	SD98
S46	SD46	SD99
S47	SD47	SD100
S48	SD48	SD101
S49	SD49	SD102
S50	SD50	SD103
S51	SD51	SD104
S52	SD52	SD105
S53	SD53	SD106

For example, the table below lists the segment output states for the S11 segment output pin.

Display data		Segment output pin (S11) state
SD11	SD64	
0	0	Both segments for the G1 and G2 digit output pins are off
0	1	Segment for the G2 digit output pin is on
1	0	Segment for the G1 digit output pin is on
1	1	Both segments for the G1 and G2 digit output pins are on

BLK and the Display Control

Since the LSI internal data (SD1 to SD106 and DM0 to DM9) is undefined when power is first applied, the display is off (S1 to S53, G1 and G2 = low) by setting the $\overline{\text{BLK}}$ pin low at the same time as power is applied. Then, meaningless display at power-on can be prevented by transferring all 144 bits of serial data from the controller while the display is off and setting $\overline{\text{BLK}}$ pin high after the transfer completes. (See Figure 3.)

Power Supply Sequence

Observe the following sequences when turning the power on and off. (See Figure 3.)

- Power on: Logic block power supply (V_{DD}) on → Driver block power supply (V_{FL}) on
- Power off: Driver block power supply (V_{FL}) off → Logic block power supply (V_{DD}) off

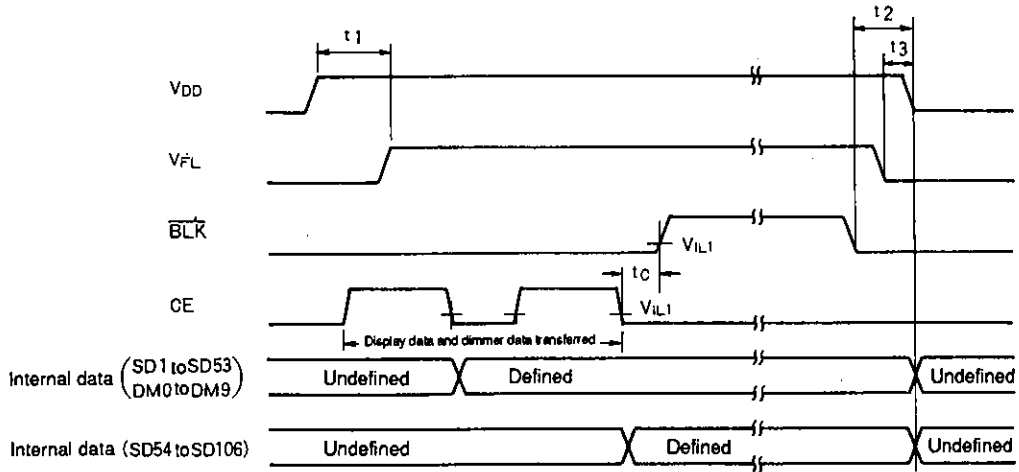

$t1 > 0$
 $t2 > 0$
 $t3 > 0$ ($t2 > t3$)
 $t_c \dots\dots 10\mu s$ min

Figure 3

Output Waveforms (S1 to S53)

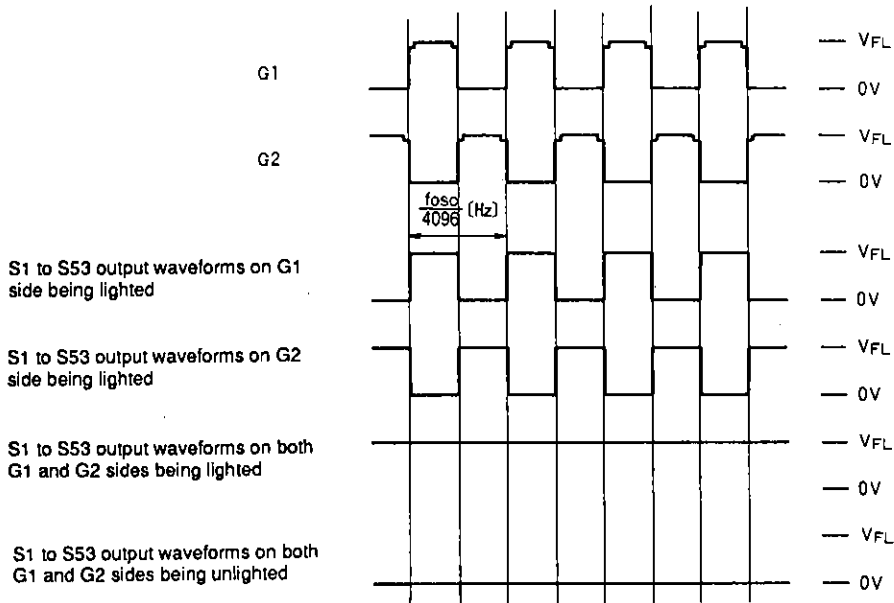

Relation between Segment and Digit Outputs

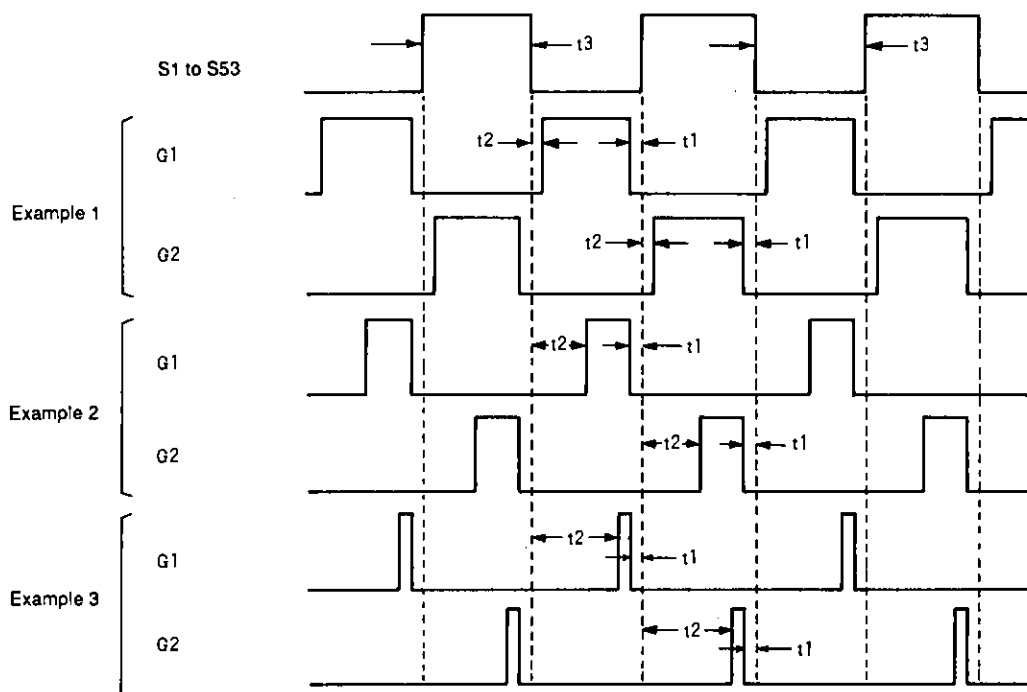

Figure 4

Description

1. Consider the examples shown in Figure 4, where data is set up so that the segment outputs S1 to S53 output a low level on the G1 digit output timing and a high level on the G2 digit output timing. (Here, the G2 side being lighted)
2. The waveforms for G1 and G2 in example 1 are output when the 10 bits of dimmer data (DM0 to DM9) are set to 3FF_H. The relation between t1 and the oscillator frequency f_{OSC} is:

$$t1 = 2/f_{OSC}$$

For example, if f_{OSC} is 1.6 [MHz]:

t1 = 2/1.6 [MHz] = 1.25 [μs]. Note that t1 and t2 will be the same period in example 1.

3. The waveforms for G1 and G2 in example 2 are those when the dimmer data (DM0 to DM9) are set to a smaller value. Although the time t1, which is from the point where digit output falls to segment output changes, does not change, the time t2, which is from the point where segment output changes to the time the digit output rises, becomes longer. When the dimmer data (DM0 to DM9) are set to 0FF_H and f_{OSC} is 1.6 [MHz],

$$\begin{aligned} \text{the frame frequency } f_{frame} &= 1/(t3 \times 2) \\ &= f_{OSC}/4096 \\ &= 391 \text{ [Hz]}, \\ \text{and } t3 &= 1.28 \text{ [ms]}. \end{aligned}$$

$$\text{Therefore, } t2 = \frac{(1.28 \text{ [ms]} - 1.25 \text{ [μs]} \times 2) \times (3FF_H - 0FF_H)}{1023} = 0.96 \text{ [ms]}.$$

4. When the dimmer data (DM0 to DM9) are set to an even smaller value, the time t2, which is from the point where segment output changes to the time the digit output rises, becomes even longer, as in example 3. Note that t1 does not change here, either.

Sample Application Circuit

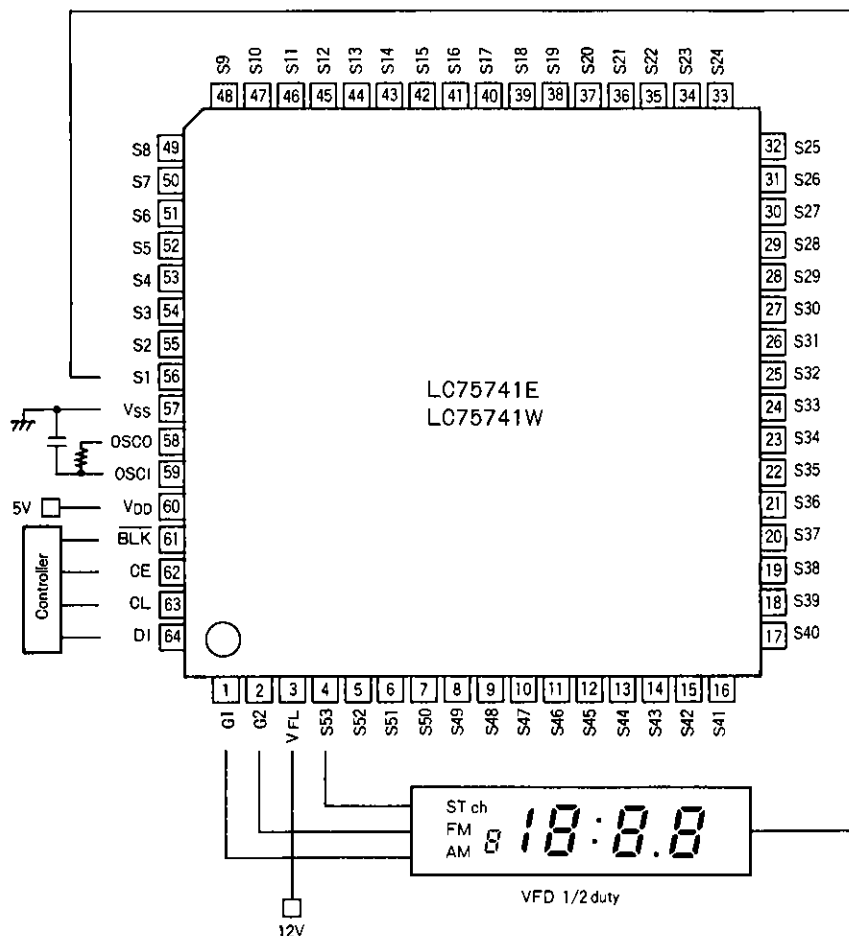

Usage Notes

1. Segment and digit waveforms

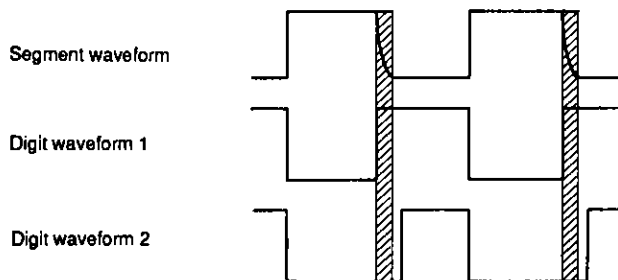

Figure 5

The segment waveform is distorted by the wiring of the VFD panel used, and furthermore, in the case of being used with essentially no dimming as in the digit waveform 1, as shown in Figure 5, the VFD panel glow dimly. By carefully considering the segment waveform, it can be seen that this problem can be resolved by applying an adequate amount of dimming, as shown in digit waveform 2. When f_{OSC} is 1.6 [MHz], we recommend using 10 bits of dimmer data in the range 000_H to $3E0_H$.

2. Serial data transfer

Since display data is transferred in two operations as shown in Figure 2, we recommend that all display data be transferred within 30 [ms] to prevent degradation of the visual quality of the displayed image.

- No products described or contained herein are intended for use in surgical implants, life-support systems, aerospace equipment, nuclear power control systems, vehicles, disaster/crime-prevention equipment and the like, the failure of which may directly or indirectly cause injury, death or property loss.
- Anyone purchasing any products described or contained herein for an above-mentioned use shall:
 - ① Accept full responsibility and indemnify and defend SANYO ELECTRIC CO., LTD., its affiliates, subsidiaries and distributors and all their officers and employees, jointly and severally, against any and all claims and litigation and all damages, cost and expenses associated with such use:
 - ② Not impose any responsibility for any fault or negligence which may be cited in any such claim or litigation on SANYO ELECTRIC CO., LTD., its affiliates, subsidiaries and distributors or any of their officers and employees jointly or severally.
- Information (including circuit diagrams and circuit parameters) herein is for example only; it is not guaranteed for volume production. SANYO believes information herein is accurate and reliable, but no guarantees are made or implied regarding its use or any infringements of intellectual property rights or other rights of third parties.

This catalog provide information as of May, 1995. Specifications and information herein are subject to change without notice.