

DATA SHEET

SAA1502ATS Safety IC for Li-ion

Preliminary specification
File under Integrated Circuits, IC11

1998 Jan 15

Safety IC for Li-ion

SAA1502ATS

FEATURES

- Integrated power switches
- Temperature protection
- Zero voltage start-up
- Discharge and charge overcurrent protection
- Automatic release of current protection at removal of charger or load
- Extremely low current consumption when battery voltage is lower than 2.3 V
- Low current consumption in normal operation mode
- Accurate voltage detection levels
- Low resistance in current path
- Able to accommodate 17.5 V charge voltage
- Read out of charge disable status
- Small package (SSOP16)
- Low external components count
- Continuous monitoring of the battery voltage and (dis)charge current.

GENERAL DESCRIPTION

The SAA1502ATS is manufactured in a Bipolar, CMOS and DMOS (BCD) Power Logic 70 process and is intended to be used as a protection circuit for single cell Li-ion battery packs. The current and voltage ratings are especially designed for use in battery packs for portable telephones such as GSM.

The circuit monitors the battery voltage, current and temperature and will disconnect the battery in case of an overload situation:

- Overdischarge protection prevents deep discharge of the cell; deep discharge of a Li-ion cell degrades the lifetime
- Overcharge protection for safety reasons
- Overcurrent protection on charge as well as discharge current rate
- Temperature protection for preventing charge or discharge at high temperatures.

It must be stated that the unit is a safety unit to be integrated inside a battery pack. It is not intended as an end of charge provision.

ORDERING INFORMATION

TYPE NUMBER	PACKAGE		
	NAME	DESCRIPTION	VERSION
SAA1502ATS	SSOP16	plastic shrink small outline package; 16 leads; body width 5.3 mm	SOT338-1

Safety IC for Li-ion

SAA1502ATS

BLOCK DIAGRAM

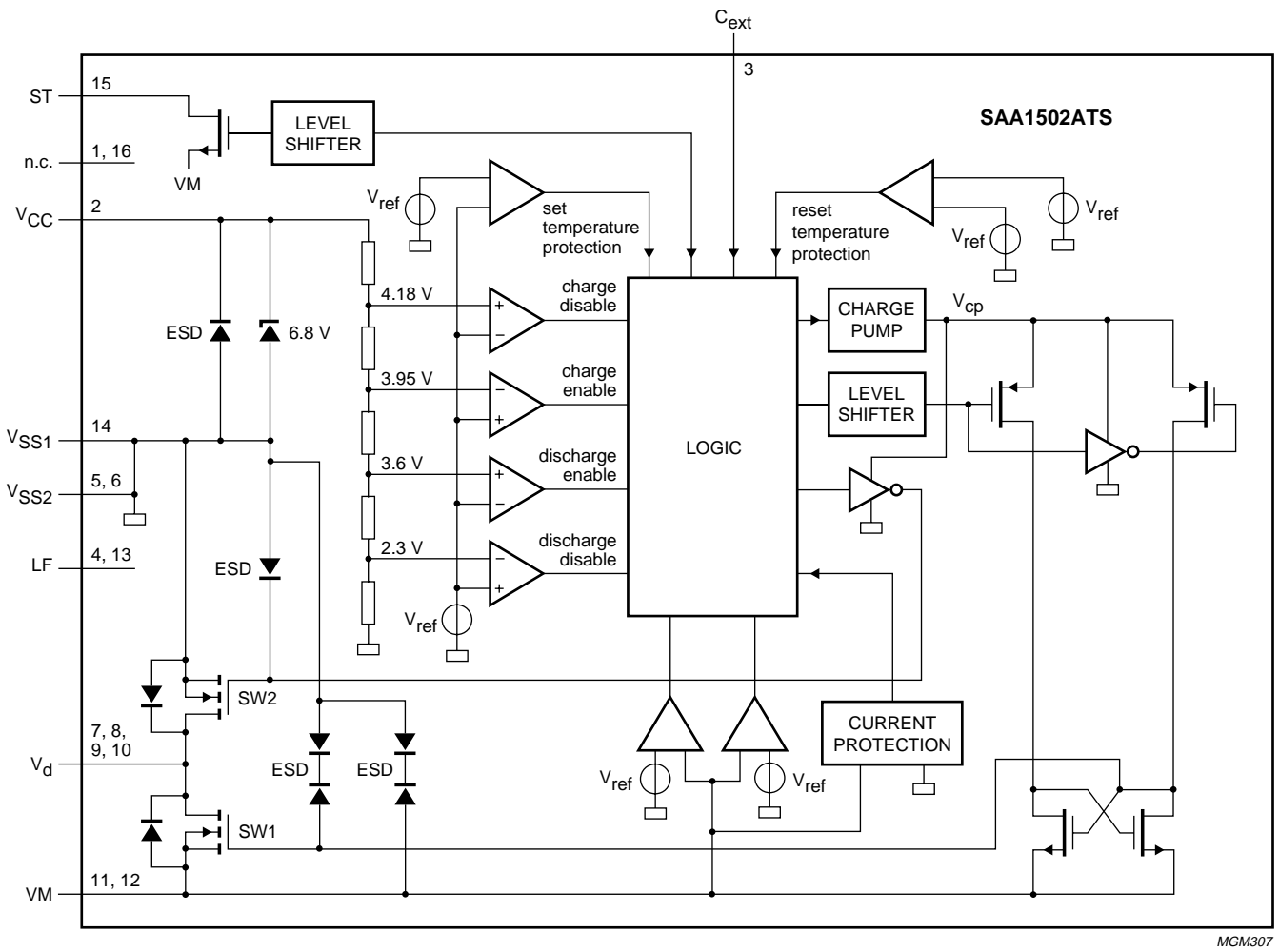

Fig.1 Block diagram.

Safety IC for Li-ion

SAA1502ATS

PINNING

SYMBOL	PIN	DESCRIPTION
n.c.	1, 16	not connected
V _{CC}	2	positive battery sense input
C _{ext}	3	external delay capacitor
LF	4, 13	leadframe connection control circuit
V _{SS2}	5, 6	negative battery input and power ground
V _d	7, 8, 9, 10	drain voltage of SW1 and SW2
VM	11, 12	negative sense input
V _{SS1}	14	ground for the control circuit
ST	15	status output

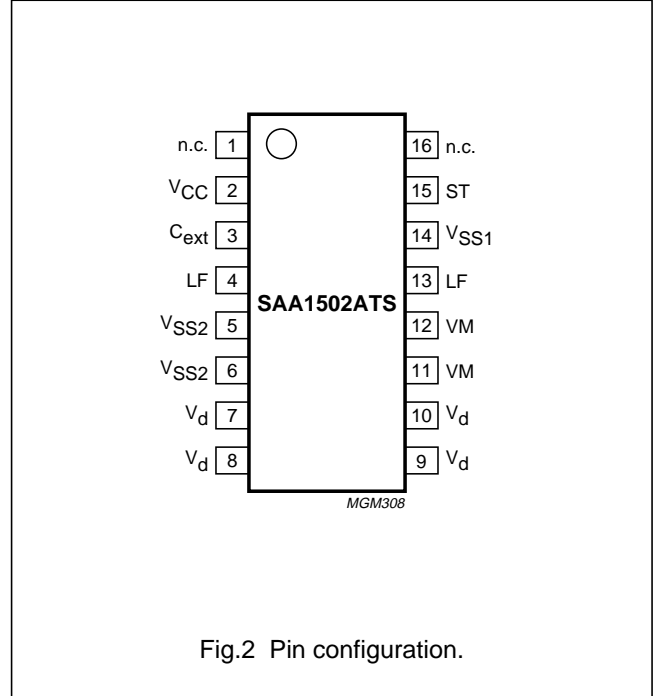

Fig.2 Pin configuration.

FUNCTIONAL DESCRIPTION

Figure 3 gives the connection diagram of a Li-ion battery pack. All that is contained within the solid perimeter is the safety IC SAA1502ATS. It is a Multichip Module (MCM), containing two separate but interconnected chips, one is the control IC and the other contains two vertical power NMOS transistors which are connected in anti series. Both transistors have their backgate connected to their source, resulting in two backgate diodes in anti series. The basic function of the SAA1502ATS is to protect a single Li-ion cell against overcharge and overdischarge for reasons of lifetime and safety. The voltage across the cell terminals is monitored continuously and compared to an accurate internal reference voltage. For battery voltages between 3.6 and 4.18 V and a (dis)charge current below the current protection level, the safety unit is in normal operating mode (see Fig.4). In this state both switches are driven with an elevated supply voltage (with a charge pump) which guarantees a low resistance in the main current path. This is important for fully utilizing the high energy density of Li-ion battery technology.

The discharge PowerMOS transistor SW2 is disabled to block further discharge, when the battery is discharged below 2.3 V. The battery voltage will increase stepwise, because of the sudden disconnection of the load. The unit will not re-enter the normal operation mode at this event

unless the battery voltage exceeds the voltage restarting level of 3.6 V.

When no charger is present in the discharge inhibit mode, the system will switch to the Power-down mode.

The current consumption of the unit (SAA1502ATS and the Li-ion cell) is then reduced to a typical value of 0.1 µA for minimizing the discharge of the battery pack.

Connecting a charger in the Power-down mode is detected by a voltage difference between V_{CC} and VM of more than 3 V. The system will then return to the discharge inhibit mode. After a short transition phase characterized by conduction of the backgate diode between the drain and source leads of SW2, the system goes to the normal operating mode and SW2 is powered again.

At zero voltage start-up, the system will start at the reset mode. A special circuit keeps the charge transistor SW1 on as much as possible.

When the battery is charged to a voltage level of 4.18 V it will enter the charge inhibit mode and the charge PowerMOS transistor SW1 is switched off, disabling charging. Connecting a load is then detected by the reversal of the voltage across SW1 (I_{dch} > 1.5 mA) and will immediately reactivate SW1, entering the discharge enable state.

Safety IC for Li-ion

SAA1502ATS

A short time is needed to charge the gate of SW1. During this time the backgate diode between drain and source of SW1 conducts.

The system will remain in the discharge enable mode unless:

- The battery voltage drops below 3.95 V, which results in re-entering normal operation. This transition is not externally noticeable, because both switches remain low ohmic.
- A charger is connected which will immediately deactivate SW1 if $I_{ch} > 280$ mA. As an additional safety precaution also $V_{CC} > 4.18$ V yields the same reaction, because a small current of a charger may be undetected with the condition of $I_{ch} > 280$ mA, leading to overcharging the Li-ion cell.

Current protection will deactivate both switches and is detected by a voltage drop or rise of V_{VM} when both switches are activated. A release of this state can only be achieved by removing the load (or charger).

The temperature protection overrules all other states and yields deactivation of both switches. This situation is activated at a junction temperature of 130 °C and released at a junction temperature of 60 °C. The temperature protection is followed by a return to its preceding mode.

Normal mode

In case of correct temperature, battery voltage and (dis)charge current, the system will be in the normal operation mode. Both the charge and discharge output will be active high, so both switches are conducting (SW1 = SW2 = 1).

Discharge inhibit mode

If the battery drops below 2.3 V, the system will switch to the discharge inhibit mode. In this mode only charging of the battery is allowed (SW1 = 1, SW2 = 0). The system will return to the normal operation mode as soon as the battery voltage will exceed 3.6 V, or by detection of a charge current.

The overdischarge detection of 2.3 V has a delay of 40 ms typical. The voltage detection level 3.6 V has a delay of 50 ms typical. Because a charge current is necessary to increase the battery voltage, the system will normally switch to the normal operation mode at $V_{CC} = 2.3$ V by detecting a charge current. But if the charge current is too small to detect, the 3.6 V detection is a backup.

To prevent an instable situation between the normal operation and the discharge inhibit mode when the battery

is charged at a voltage below 2.3 V, an extra condition of $V_{bat} > 2.3$ V is included going from the discharge inhibit to the normal operation mode.

Power-down mode

At low battery voltage the supply current is reduced to 100 nA for minimizing the discharge of the battery by the SAA1502ATS.

At the Power-down mode all analog circuitry, except circuitry for detecting a charger present ($V_{CC} - V_{VM} > 3$ V), is disabled. The Power-down mode is entered when the system is in the discharge inhibit mode and no charger is present. The discharge inhibit mode will be entered again as soon as a charger is connected.

The detection of a charger is accomplished by detecting a voltage difference of 3 V between V_{CC} and VM. In this mode the voltage difference (see Fig.5) is:

$$V_{CC} - V_{VM} = V_{bat} - V_{R1} + V_{J(DO)} + V_{ds(CO)} \approx V_{bat} + 0.6 \text{ V.}$$

So in the application the battery has to be charged in the Power-down mode until such a voltage that $V_{CC} - V_{VM} = 3$ V.

Reset mode

If the battery voltage is below 1.9 V, the system will be in the reset mode. Because in this mode the charge pump is disabled and battery charging should be possible, the charge FET is switched on with a reduced V_{gs} voltage.

As soon as the battery voltage exceeds 2.25 V the system will switch to the discharge inhibit mode and the charge pump will be activated again.

Zero voltage start-up

The system has to be able to charge the battery at '0 Volt'. This means that when connecting a charger in case of a complete empty battery, the charge FET has to be active. In the reset mode the charge FET (SW1) is connected via a diode to V_{CC} , so that the charge FET will be active when the V_{VM} voltage is negative. The discharge inhibit mode will be entered as soon as a battery voltage exceeds 2.25 V.

Charge inhibit mode

If the battery voltage exceeds 4.18 V, the charge inhibit mode will be entered. At this mode the battery can only be discharged (SW1 = 0, SW2 = 1). The overcharge detection has a delay of 40 ms. This delay can be increased by an external capacitor. The delay time is then

Safety IC for Li-ion

SAA1502ATS

defined as:

$$t_d = 40 + (37 \times C_{ext}) \text{ [ms]}, \text{ with } C_{ext} \text{ in nF.}$$

The system will return to the normal operation mode from the charge inhibit mode when the battery voltage drops below 3.95 V.

From the discharge enable mode the charge inhibit mode will also be entered as soon as a charge current is detected.

Discharge enable mode

When the system is in the charge inhibit mode, charging of the battery is disabled because switch SW1 is turned off. Discharge of the battery will then occur via the backgate diode of SW1. So the output voltage will be approximately 0.6 V lower and also dissipation of the backgate diode of SW1 occurs. It would be preferable to turn both switches on at that time without allowing charging of the battery until the battery voltage has dropped to 3.95 V.

If a discharge current larger than 1.5 mA is detected in the charge inhibit mode, the system will activate the discharge enable mode, activating both switches. From the discharge enable mode the charge inhibit mode will be re-entered as soon as a charge current is detected larger than 280 mA or the battery voltage exceeds 4.18 V.

The detection of a higher voltage than 4.18 V is a backup. If the battery is charged with a lower charge current than 280 mA, the system will not switch from the discharge enable mode to the charge inhibit mode. Eventually, if the battery is overcharged because of a small charge current, the battery voltage will exceed 4.18 V and the system will switch to the charge inhibit mode.

The system will return to the normal operation mode from the discharge enable mode when the battery voltage drops below 3.95 V.

If the system is in the charge inhibit mode, it will mostly go to the normal mode via the discharge enable mode. But if the system is in the charge inhibit state and the system is stored for several years, the battery voltage can drop because of the battery discharge by the SAA1502ATS and the self-discharge of the battery. So a voltage drop of the battery is possible, without detecting a discharge current. Because of this, the normal operation mode should also be entered from the charge inhibit state when the battery voltage is below 3.95 V and not only from the discharge enable mode. In this way, charging a battery is always possible if the battery voltage is below 3.95 V.

Temperature protection

Internally the system will switch between the different modes as given in the state diagram, independent of the temperature. As the junction temperature exceeds 130 °C, the output signals will be overruled and switched to zero (SW1 = SW2 = 0).

The supply current will be reduced to approximately 100 nA when the Power-down or reset mode is activated. In these modes the temperature protection is deactivated.

When the junction temperature drops below 60 °C, the output signals will not be overruled any more.

Overcurrent protection

When the (dis)charge current exceeds the specified maximum value, the current protection mode is entered.

An extra condition of SW1 = SW2 = 1 is necessary because of the next situation:

If the system is in the discharge inhibit and a charge current is detected (e.g. $V_{VM} = -0.6 \text{ V}$) the normal operation mode will be entered. Because of a minimum time in which the gate capacitors have to be charged, the V_{VM} voltage will be -0.6 V for a short period, when the system is already in the normal operation mode. A V_{VM} voltage of -0.6 V could also occur when the system is charged with current exceeding the maximum charge current. To prevent that a maximum charge current is detected when coming from the discharge inhibit state, the system waits until both SW1 and SW2 are fully charged before a maximum (dis)charge current is detected.

So the voltages at SW1 and SW2 are measured to be sure that the normal operation mode is stabilized before the current protection mode can be entered.

The same applies when entering the discharge enable state from the charge inhibit state by detecting a discharge current.

The delay of the current protection as function of the (dis)charge current is given in Fig.8.

Safety IC for Li-ion

SAA1502ATS

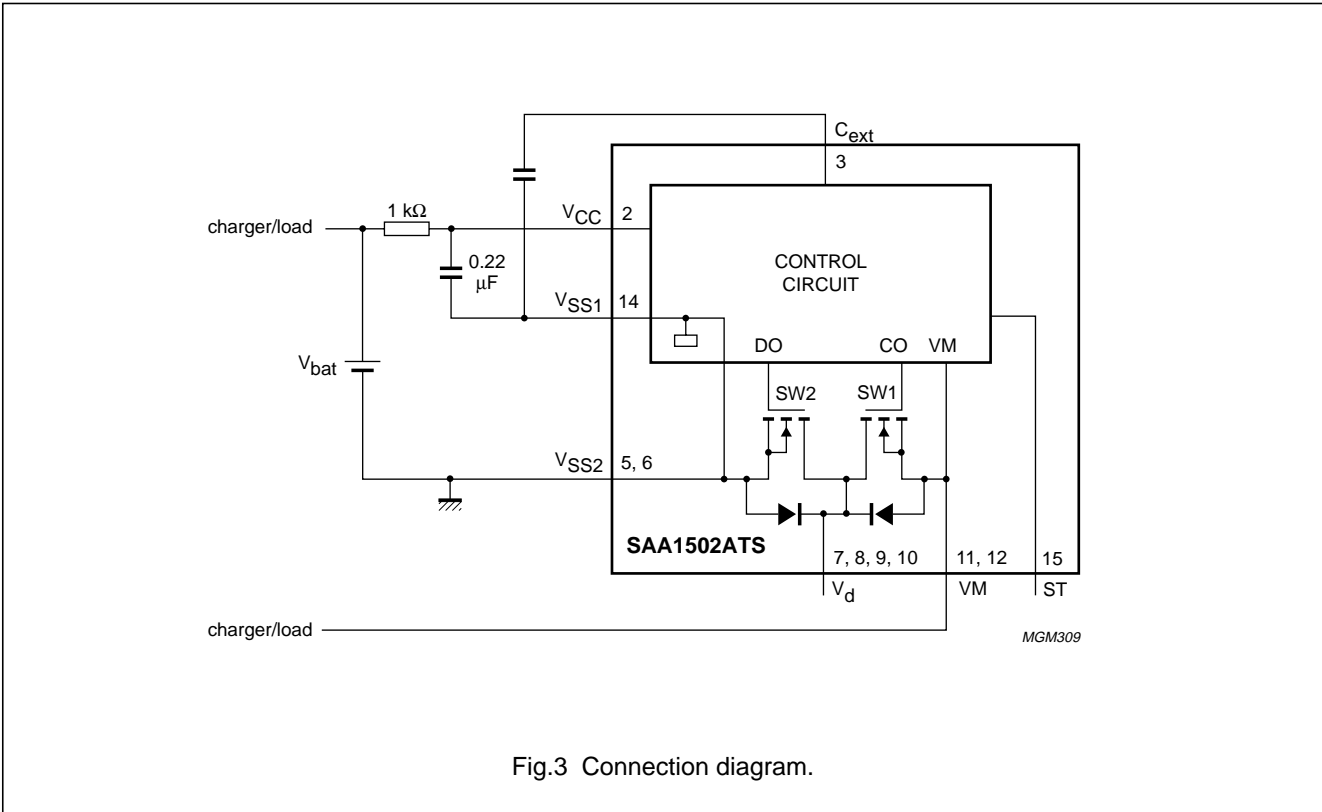

Fig.3 Connection diagram.

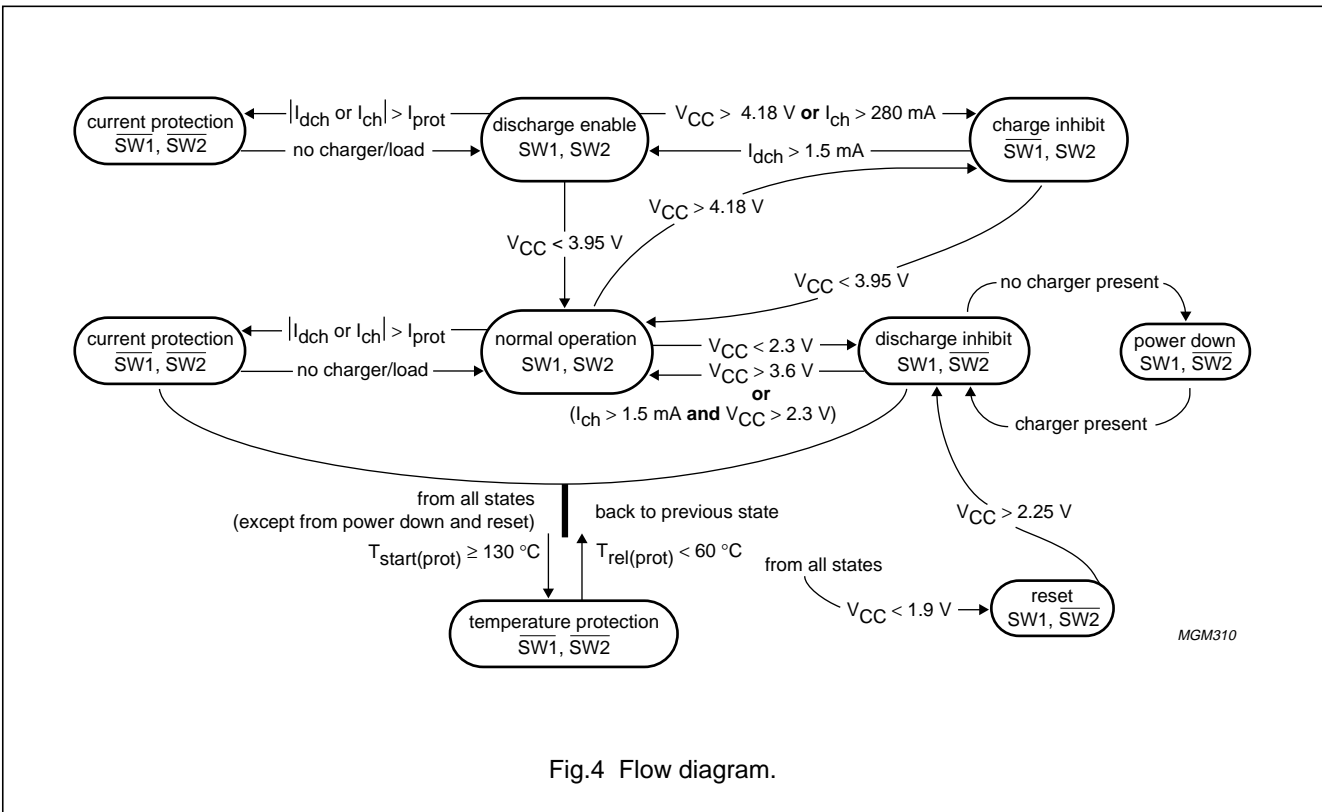

Fig.4 Flow diagram.

Safety IC for Li-ion

SAA1502ATS

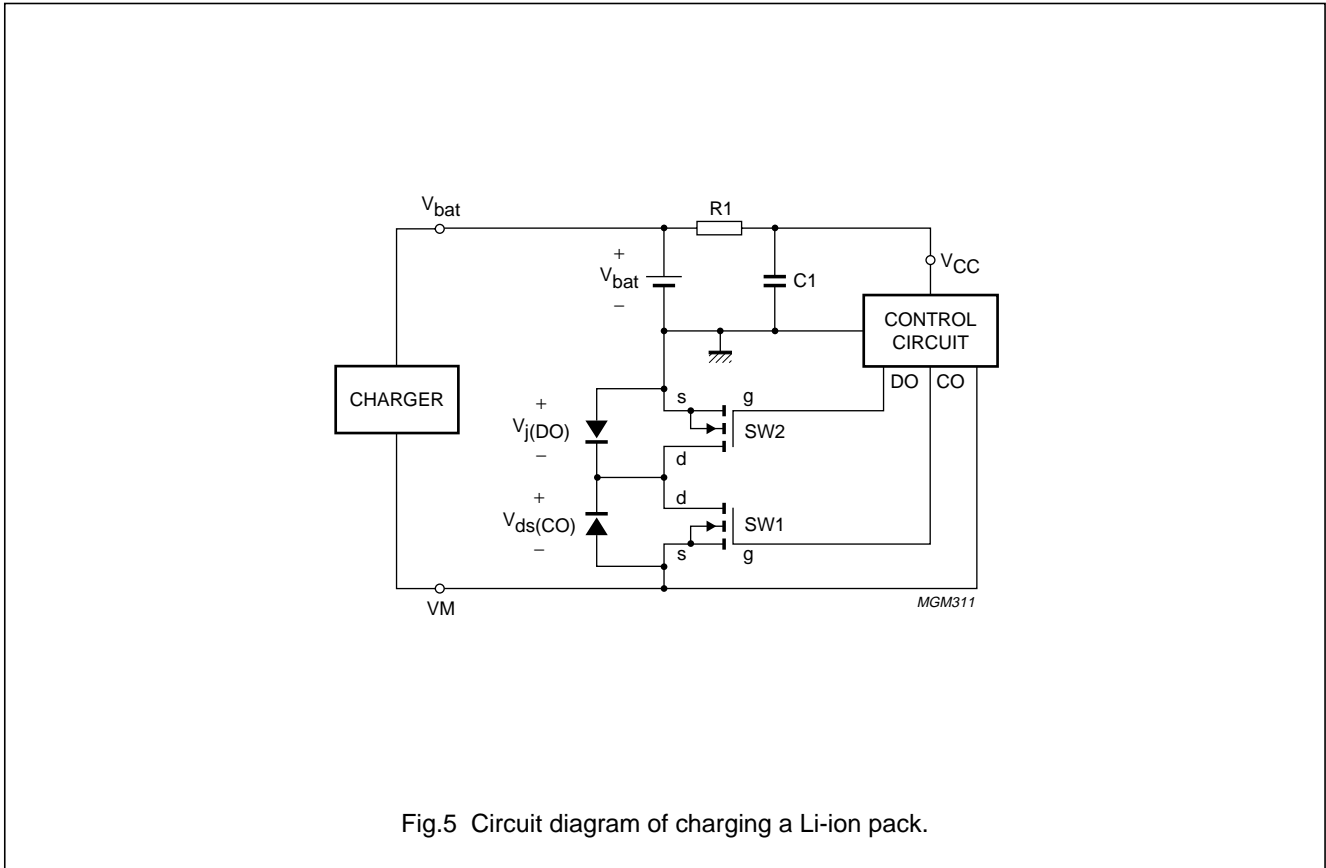

Fig.5 Circuit diagram of charging a Li-ion pack.

Safety IC for Li-ion

SAA1502ATS

LIMITING VALUES

In accordance with the Absolute Maximum Rating System (IEC 134); voltages with respect to pin V_{SS2} .

SYMBOL	PARAMETER	CONDITIONS	MIN.	MAX.	UNIT
V_{CC}	positive battery sense input voltage	DC constant	-0.3	+4.5	V
$V_{CC(\text{clamp})}$	V_{CC} clamping voltage	$t < 60 \text{ ms}$ and $I_{CC} = 7 \text{ mA}$	-	8.5	V
I_{CC}	maximum current through the V_{CC} clamp		-	7	mA
V_{VM}	negative sense input voltage		$V_{CC} - 17.5$	V_{CC}	V
V_{ST}	status output voltage		V_{VM}	V_{CC}	V
$I_{R\text{path}}$	current through SW1 and SW2		-	27	A
T_{amb}	operating ambient temperature		-25	+80	°C
T_{stg}	storage temperature		-55	+150	°C
$ I_{V_{SS-VM}} $	maximum body diode current (DC value)		-	800	mA

THERMAL CHARACTERISTICS

SYMBOL	PARAMETER	CONDITIONS	VALUE	UNIT
$R_{\text{th}(j-a)}$	thermal resistance from junction to ambient	in free air	165	K/W
$R_{\text{th}(j-\text{pin})}$	thermal resistance from junction to pin		22	K/W

Safety IC for Li-ion

SAA1502ATS

CHARACTERISTICS

$T_j = 25\text{ °C}$; all voltages with respect to V_{SS2} ; positive currents flow into the IC.

SYMBOL	PARAMETER	CONDITIONS	MIN.	TYP.	MAX.	UNIT
Supply behaviour						
V_{CC}	positive battery sense input voltage		0	–	4.5	V
I_{CC}	supply current	$V_{CC} = 4.0\text{ V}; -13.5\text{ V} \leq V_{VM} \leq 0$	4.0	7.0	10	μA
I_q	quiescent current	Power-down/reset mode ($V_{CC} = 2.0\text{ V}$)	0.03	0.1	0.3	μA
$V_{CC}-V_{VM}$	minimum charge voltage	at zero charge	1.8	2.4	3.0	V
Voltage detection						
$V_{ec(det)}$	excess charge detection voltage	measured at terminals of the battery and $T_j = 25\text{ °C}$	4.15	4.18	4.20	V
		measured at terminals of the battery and $T_j = -5\text{ to }+55\text{ °C}$	4.145	4.18	4.21	V
$t_{ec(det)}$	excess charge delay time $V_{ec(det)}$	C_{ext} not connected	20	40	60	ms
		$C_{ext} = 33\text{ nF} (\pm 10\%)$	0.5	1.25	2	s
$V_{ec(rel)}$	excess charge release voltage		3.82	3.95	4.08	V
$t_{ec(rel)}$	excess charge delay time $V_{ec(rel)}$		25	50	75	ms
$V_{ed(det)}$	excess discharge detection voltage		2.2	2.3	2.4	V
$t_{ed(det)}$	excess discharge delay time $V_{ed(det)}$		20	40	60	ms
$V_{ed(rel)}$	excess discharge release voltage		3.3	3.6	3.9	V
$t_{ed(rel)}$	excess discharge delay time $V_{ed(rel)}$		25	50	75	ms
$ I_{VSS-VM} $	(dis)charge current detection	charge inhibit state	0.05	1.5	37.5	mA
		discharge enable state	150	280	475	mA
		discharge inhibit state	0.05	1.5	37.5	mA
V_{VM}	negative sense input voltage	discharge inhibit state; no charge current	-7	-12	-20	mV
		current protection mode no load detection	70	90	120	mV
		no charger detection	-7	-12	-20	mV
$V_{CC}-V_{VM}$	charge present detection voltage	Power-down mode	2.4	3.0	3.6	V
V_{CC}	positive battery sense input voltage	start of reset mode	1.7	1.9	2.1	V
		excess of reset mode	2.05	2.25	2.45	V
$t_{d(on)}$	switch-on delay time SW1/SW2	$V_{CC} = 4.0\text{ V}$	–	100	–	μs
$t_{d(off)}$	switch-off delay time SW1/SW2	$V_{CC} = 4.0\text{ V}$	–	100	–	μs

Safety IC for Li-ion

SAA1502ATS

SYMBOL	PARAMETER	CONDITIONS	MIN.	TYP.	MAX.	UNIT
Power transistors						
R _{path}	main current path resistance	V _{CC} = 2.5 V; I _{VSS-VM} = 2 A	52	66	80	mΩ
		V _{CC} = 4.0 V; I _{VSS-VM} = 2 A	48	60	72	mΩ
SW1 transistor						
R _{path(SW1)}	current path resistance	V _{CC} = 2.5 V; I _{VSS-VM} = 2 A	26	33	40	mΩ
		V _{CC} = 4.0 V; I _{VSS-VM} = 2 A	24	30	36	mΩ
SW2 transistor						
R _{path(SW2)}	current path resistance	V _{CC} = 2.5 V; I _{VSS-VM} = 2 A	26	33	40	mΩ
		V _{CC} = 4.0 V; I _{VSS-VM} = 2 A	24	30	36	mΩ
Temperature protection						
T _{start(prot)}	start of the temperature protection		120	130	140	°C
T _{rel(prot)}	release of the temperature protection		50	60	70	°C
Current detection at V_{CC} = 4 V; see Fig.8						
I _{prot(min)}	minimum current protection level	DC level	3.5	5	7	A
t _d	delay time at I _{prot} = 8 A		2	20	200	ms
t _{d(min)}	minimum delay time		190	–	430	μs
Status; see Table 1 and Fig.7						
I _{ST}	output current	ST = 1; V _{CC} – V _{VM} = 17.5 V; V _{ST} – V _{VM} = 0.5 V	40	–	200	μA
		ST = 1; V _{CC} – V _{VM} = 4 V; V _{ST} – V _{VM} = 0.5 V	10	–	100	μA
V _{ST}	output voltage	ST = 1; I _{ST} = 40 μA; V _{CC} – V _{VM} = 17.5 V	–	–	0.5	V
		ST = 1; I _{ST} = 10 μA; V _{CC} – V _{VM} = 4 V	–	–	0.5	V

Table 1 Functional table of the status output (ST);
note 1

CONDITIONS	OUTPUT
Normal operation	0
Charge inhibit	1
Discharge enable	0
Discharge inhibit	0
Power-down	0
Current protection	1
Temperature protection	1

Note

1. At which: '0' is active off, and '1' is active on.

Safety IC for Li-ion

SAA1502ATS

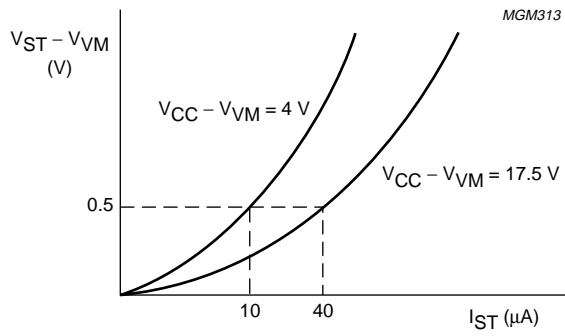

Fig.7 Status output current at different charge voltages.

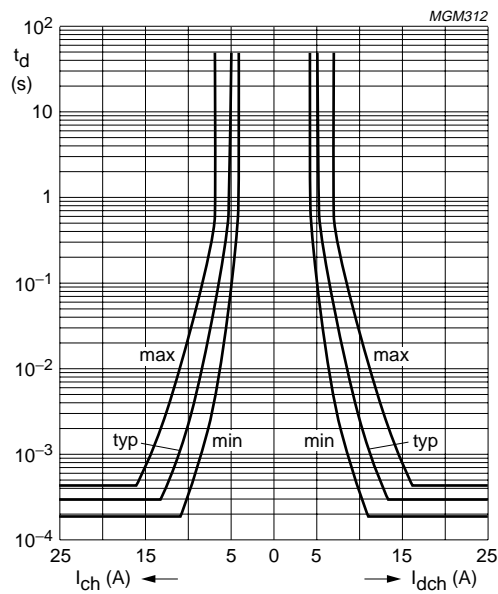

Fig.8 Current protection delay.

Safety IC for Li-ion

SAA1502ATS

APPLICATION INFORMATION

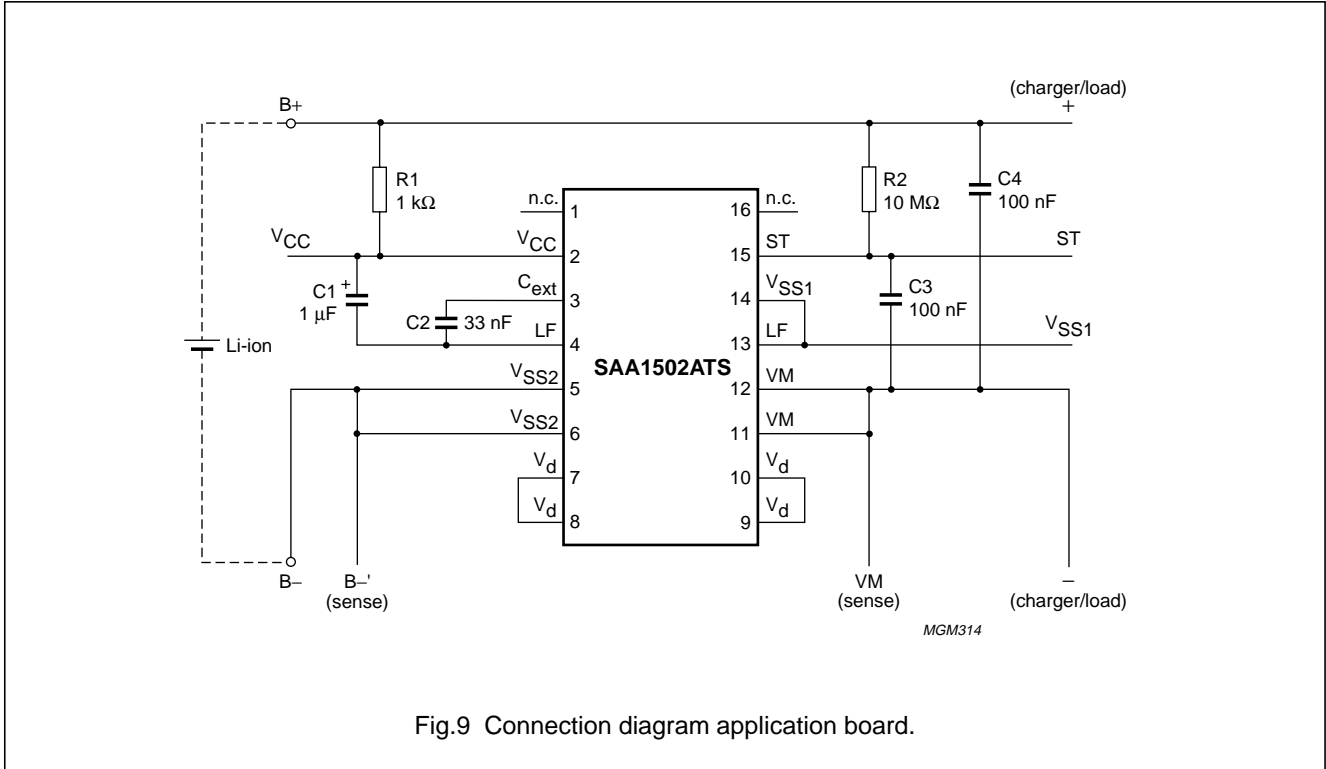
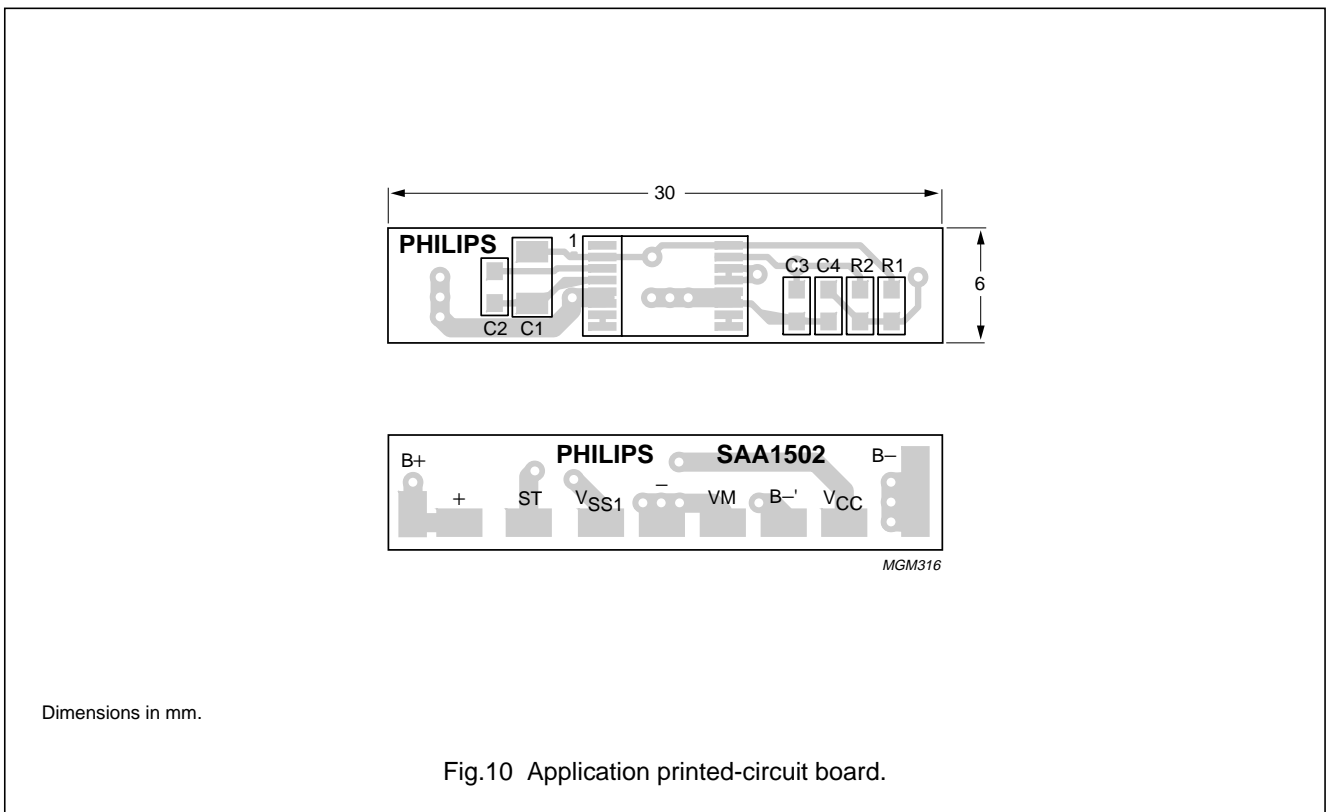

Fig.9 Connection diagram application board.



Dimensions in mm.

Fig.10 Application printed-circuit board.

Safety IC for Li-ion

SAA1502ATS

PACKAGE OUTLINE

SSOP16: plastic shrink small outline package; 16 leads; body width 5.3 mm

SOT338-1

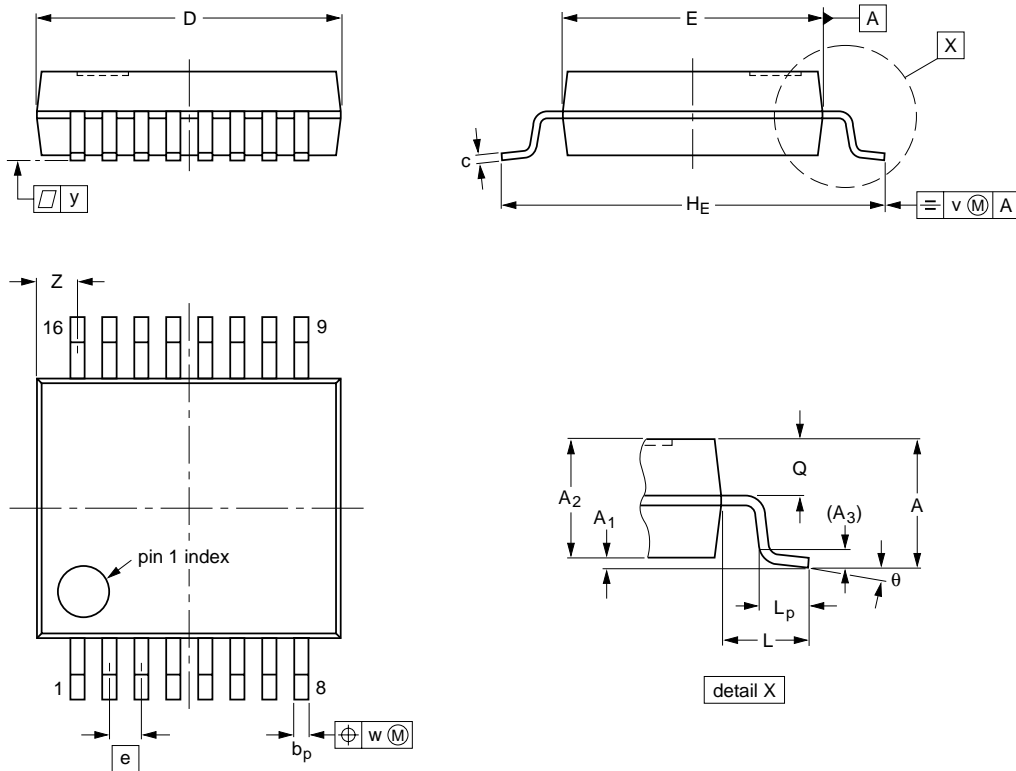

DIMENSIONS (mm are the original dimensions)

UNIT	A max.	A ₁	A ₂	A ₃	b _p	c	D ⁽¹⁾	E ⁽¹⁾	e	H _E	L	L _p	Q	v	w	y	Z ⁽¹⁾	θ
mm	2.0	0.21 0.05	1.80 1.65	0.25	0.38 0.25	0.20 0.09	6.4 6.0	5.4 5.2	0.65	7.9 7.6	1.25	1.03 0.63	0.9 0.7	0.2	0.13	0.1	1.00 0.55	8° 0°

Note

1. Plastic or metal protrusions of 0.25 mm maximum per side are not included.

OUTLINE VERSION	REFERENCES				EUROPEAN PROJECTION	ISSUE DATE
	IEC	JEDEC	EIAJ			
SOT338-1		MO-150AC				94-01-14 95-02-04

Safety IC for Li-ion

SAA1502ATS

SOLDERING

Introduction

There is no soldering method that is ideal for all IC packages. Wave soldering is often preferred when through-hole and surface mounted components are mixed on one printed-circuit board. However, wave soldering is not always suitable for surface mounted ICs, or for printed-circuits with high population densities. In these situations reflow soldering is often used.

This text gives a very brief insight to a complex technology. A more in-depth account of soldering ICs can be found in our *"IC Package Databook"* (order code 9398 652 90011).

Reflow soldering

Reflow soldering techniques are suitable for all SSOP packages.

Reflow soldering requires solder paste (a suspension of fine solder particles, flux and binding agent) to be applied to the printed-circuit board by screen printing, stencilling or pressure-syringe dispensing before package placement.

Several techniques exist for reflowing; for example, thermal conduction by heated belt. Dwell times vary between 50 and 300 seconds depending on heating method. Typical reflow temperatures range from 215 to 250 °C.

Preheating is necessary to dry the paste and evaporate the binding agent. Preheating duration: 45 minutes at 45 °C.

Wave soldering

Wave soldering is **not** recommended for SSOP packages. This is because of the likelihood of solder bridging due to closely-spaced leads and the possibility of incomplete solder penetration in multi-lead devices.

If wave soldering cannot be avoided, the following conditions must be observed:

- **A double-wave (a turbulent wave with high upward pressure followed by a smooth laminar wave) soldering technique should be used.**
- **The longitudinal axis of the package footprint must be parallel to the solder flow and must incorporate solder thieves at the downstream end.**

Even with these conditions, only consider wave soldering SSOP packages that have a body width of 4.4 mm, that is SSOP16 (SOT369-1) or SSOP20 (SOT266-1).

During placement and before soldering, the package must be fixed with a droplet of adhesive. The adhesive can be applied by screen printing, pin transfer or syringe dispensing. The package can be soldered after the adhesive is cured.

Maximum permissible solder temperature is 260 °C, and maximum duration of package immersion in solder is 10 seconds, if cooled to less than 150 °C within 6 seconds. Typical dwell time is 4 seconds at 250 °C.

A mildly-activated flux will eliminate the need for removal of corrosive residues in most applications.

Repairing soldered joints

Fix the component by first soldering two diagonally-opposite end leads. Use only a low voltage soldering iron (less than 24 V) applied to the flat part of the lead. Contact time must be limited to 10 seconds at up to 300 °C. When using a dedicated tool, all other leads can be soldered in one operation within 2 to 5 seconds between 270 and 320 °C.

Safety IC for Li-ion

SAA1502ATS

DEFINITIONS

Data sheet status	
Objective specification	This data sheet contains target or goal specifications for product development.
Preliminary specification	This data sheet contains preliminary data; supplementary data may be published later.
Product specification	This data sheet contains final product specifications.
Limiting values	
Limiting values given are in accordance with the Absolute Maximum Rating System (IEC 134). Stress above one or more of the limiting values may cause permanent damage to the device. These are stress ratings only and operation of the device at these or at any other conditions above those given in the Characteristics sections of the specification is not implied. Exposure to limiting values for extended periods may affect device reliability.	
Application information	
Where application information is given, it is advisory and does not form part of the specification.	

LIFE SUPPORT APPLICATIONS

These products are not designed for use in life support appliances, devices, or systems where malfunction of these products can reasonably be expected to result in personal injury. Philips customers using or selling these products for use in such applications do so at their own risk and agree to fully indemnify Philips for any damages resulting from such improper use or sale.

Safety IC for Li-ion

SAA1502ATS

NOTES

Safety IC for Li-ion

SAA1502ATS

NOTES

Philips Semiconductors – a worldwide company

Argentina: see South America

Australia: 34 Waterloo Road, NORTH RYDE, NSW 2113,
Tel. +61 2 9805 4455, Fax. +61 2 9805 4466

Austria: Computerstr. 6, A-1101 WIEN, P.O. Box 213, Tel. +43 160 1010,
Fax. +43 160 101 1210

Belarus: Hotel Minsk Business Center, Bld. 3, r. 1211, Volodarski Str. 6,
220050 MINSK, Tel. +375 172 200 733, Fax. +375 172 200 773

Belgium: see The Netherlands

Brazil: see South America

Bulgaria: Philips Bulgaria Ltd., Energoproject, 15th floor,
51 James Bourchier Blvd., 1407 SOFIA,
Tel. +359 2 689 211, Fax. +359 2 689 102

Canada: PHILIPS SEMICONDUCTORS/COMPONENTS,
Tel. +1 800 234 7381

China/Hong Kong: 501 Hong Kong Industrial Technology Centre,
72 Tat Chee Avenue, Kowloon Tong, HONG KONG,
Tel. +852 2319 7888, Fax. +852 2319 7700

Colombia: see South America

Czech Republic: see Austria

Denmark: Prags Boulevard 80, PB 1919, DK-2300 COPENHAGEN S,
Tel. +45 32 88 2636, Fax. +45 31 57 0044

Finland: Sinikalliontie 3, FIN-02630 ESPOO,
Tel. +358 9 615800, Fax. +358 9 61580920

France: 51 Rue Carnot, BP317, 92156 SURESNES Cedex,
Tel. +33 1 40 99 6161, Fax. +33 1 40 99 6427

Germany: Hammerbrookstraße 69, D-20097 HAMBURG,
Tel. +49 40 23 53 60, Fax. +49 40 23 536 300

Greece: No. 15, 25th March Street, GR 17778 TAVROS/ATHENS,
Tel. +30 1 4894 339/239, Fax. +30 1 4814 240

Hungary: see Austria

India: Philips INDIA Ltd, Band Box Building, 2nd floor,
254-D, Dr. Annie Besant Road, Worli, MUMBAI 400 025,
Tel. +91 22 493 8541, Fax. +91 22 493 0966

Indonesia: see Singapore

Ireland: Newstead, Clonskeagh, DUBLIN 14,
Tel. +353 1 7640 000, Fax. +353 1 7640 200

Israel: RAPAC Electronics, 7 Kehilat Saloniki St, PO Box 18053,
TEL AVIV 61180, Tel. +972 3 645 0444, Fax. +972 3 649 1007

Italy: PHILIPS SEMICONDUCTORS, Piazza IV Novembre 3,
20124 MILANO, Tel. +39 2 6752 2531, Fax. +39 2 6752 2557

Japan: Philips Bldg 13-37, Kohnan 2-chome, Minato-ku, TOKYO 108,
Tel. +81 3 3740 5130, Fax. +81 3 3740 5077

Korea: Philips House, 260-199 Itaewon-dong, Yongsan-ku, SEOUL,
Tel. +82 2 709 1412, Fax. +82 2 709 1415

Malaysia: No. 76 Jalan Universiti, 46200 PETALING JAYA, SELANGOR,
Tel. +60 3 750 5214, Fax. +60 3 757 4880

Mexico: 5900 Gateway East, Suite 200, EL PASO, TEXAS 79905,
Tel. +9-5 800 234 7381

Middle East: see Italy

Netherlands: Postbus 90050, 5600 PB EINDHOVEN, Bldg. VB,
Tel. +31 40 27 82785, Fax. +31 40 27 88399

New Zealand: 2 Wagener Place, C.P.O. Box 1041, AUCKLAND,
Tel. +64 9 849 4160, Fax. +64 9 849 7811

Norway: Box 1, Manglerud 0612, OSLO,
Tel. +47 22 74 8000, Fax. +47 22 74 8341

Philippines: Philips Semiconductors Philippines Inc.,
106 Valero St. Salcedo Village, P.O. Box 2108 MCC, MAKATI,
Metro MANILA, Tel. +63 2 816 6380, Fax. +63 2 817 3474

Poland: Ul. Lukiska 10, PL 04-123 WARSZAWA,
Tel. +48 22 612 2831, Fax. +48 22 612 2327

Portugal: see Spain

Romania: see Italy

Russia: Philips Russia, Ul. Usatcheva 35A, 119048 MOSCOW,
Tel. +7 095 755 6918, Fax. +7 095 755 6919

Singapore: Lorong 1, Toa Payoh, SINGAPORE 1231,
Tel. +65 350 2538, Fax. +65 251 6500

Slovakia: see Austria

Slovenia: see Italy

South Africa: S.A. PHILIPS Pty Ltd., 195-215 Main Road Martindale,
2092 JOHANNESBURG, P.O. Box 7430 Johannesburg 2000,
Tel. +27 11 470 5911, Fax. +27 11 470 5494

South America: Al. Vicente Pinzon, 173, 6th floor,
04547-130 SÃO PAULO, SP, Brazil,
Tel. +55 11 821 2333, Fax. +55 11 821 2382

Spain: Balmes 22, 08007 BARCELONA,
Tel. +34 3 301 6312, Fax. +34 3 301 4107

Sweden: Kottbygatan 7, Akalla, S-16485 STOCKHOLM,
Tel. +46 8 632 2000, Fax. +46 8 632 2745

Switzerland: Allmendstrasse 140, CH-8027 ZÜRICH,
Tel. +41 1 488 2686, Fax. +41 1 488 3263

Taiwan: Philips Semiconductors, 6F, No. 96, Chien Kuo N. Rd., Sec. 1,
TAIPEI, Taiwan Tel. +886 2 2134 2865, Fax. +886 2 2134 2874

Thailand: PHILIPS ELECTRONICS (THAILAND) Ltd.,
209/2 Sanpavuth-Bangna Road Prakanong, BANGKOK 10260,
Tel. +66 2 745 4090, Fax. +66 2 398 0793

Turkey: Talatpasa Cad. No. 5, 80640 GÜLTEPE/ISTANBUL,
Tel. +90 212 279 2770, Fax. +90 212 282 6707

Ukraine: PHILIPS UKRAINE, 4 Patrice Lumumba str., Building B, Floor 7,
252042 KIEV, Tel. +380 44 264 2776, Fax. +380 44 268 0461

United Kingdom: Philips Semiconductors Ltd., 276 Bath Road, Hayes,
MIDDLESEX UB3 5BX, Tel. +44 181 730 5000, Fax. +44 181 754 8421

United States: 811 East Arques Avenue, SUNNYVALE, CA 94088-3409,
Tel. +1 800 234 7381

Uruguay: see South America

Vietnam: see Singapore

Yugoslavia: PHILIPS, Trg N. Pasica 5/v, 11000 BEOGRAD,
Tel. +381 11 625 344, Fax. +381 11 635 777

For all other countries apply to: Philips Semiconductors,
International Marketing & Sales Communications, Building BE-p, P.O. Box 218,
5600 MD EINDHOVEN, The Netherlands, Fax. +31 40 27 24825

Internet: <http://www.semiconductors.philips.com>

© Philips Electronics N.V. 1998

SCA57

All rights are reserved. Reproduction in whole or in part is prohibited without the prior written consent of the copyright owner.

The information presented in this document does not form part of any quotation or contract, is believed to be accurate and reliable and may be changed without notice. No liability will be accepted by the publisher for any consequence of its use. Publication thereof does not convey nor imply any license under patent- or other industrial or intellectual property rights.

Printed in The Netherlands

297027/1200/01/pp20

Date of release: 1998 Jan 15

Document order number: 9397 750 02706

Let's make things better.

**Philips
Semiconductors**



PHILIPS