

NPN Silicon RF Transistor

- For low noise, high-gain broadband amplifiers at collector currents from 0.5mA to 12mA
- $f_T = 8\text{GHz}$
 $F = 1.45\text{dB}$ at 900MHz

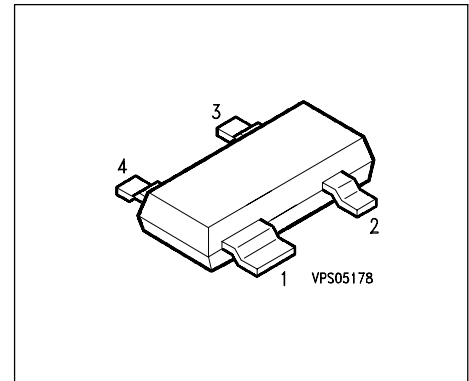

ESD: Electrostatic discharge sensitive device, observe handling precaution!

| Type | Marking | Ordering Code | Pin Configuration | | | | Package |
|---------|---------|---------------|-------------------|-------|-------|-------|---------|
| BFP 181 | RFs | Q62702-F1271 | 1 = C | 2 = E | 3 = B | 4 = E | SOT-143 |

Maximum Ratings

| Parameter | Symbol | Values | Unit |
|--|-----------|----------------|------------------|
| Collector-emitter voltage | V_{CEO} | 12 | V |
| Collector-emitter voltage | V_{CES} | 20 | |
| Collector-base voltage | V_{CBO} | 20 | |
| Emitter-base voltage | V_{EBO} | 2 | |
| Collector current | I_C | 20 | mA |
| Base current | I_B | 2 | |
| Total power dissipation $T_S \leq 75\text{ }^\circ\text{C}$ | P_{tot} | 175 | mW |
| Junction temperature | T_j | 150 | |
| Ambient temperature | T_A | - 65 ... + 150 | $^\circ\text{C}$ |
| Storage temperature | T_{stg} | - 65 ... + 150 | |

Thermal Resistance

| | | | |
|--|------------|------------|-----|
| Junction - soldering point ¹⁾ | R_{thJS} | ≤ 430 | K/W |
|--|------------|------------|-----|

1) T_S is measured on the collector lead at the soldering point to the pcb.

Electrical Characteristics at $T_A = 25^\circ\text{C}$, unless otherwise specified.

| Parameter | Symbol | Values | | | Unit |
|---|---------------|--------|------|------|---------------|
| | | min. | typ. | max. | |
| DC Characteristics | | | | | |
| Collector-emitter breakdown voltage $I_C = 1 \text{ mA}, I_B = 0$ | $V_{(BR)CEO}$ | 12 | - | - | V |
| Collector-emitter cutoff current $V_{CE} = 20 \text{ V}, V_{BE} = 0$ | I_{CES} | - | - | 100 | μA |
| Collector-base cutoff current $V_{CB} = 10 \text{ V}, I_E = 0$ | I_{CBO} | - | - | 100 | nA |
| Emitter-base cutoff current $V_{EB} = 1 \text{ V}, I_C = 0$ | I_{EBO} | - | - | 1 | μA |
| DC current gain $I_C = 5 \text{ mA}, V_{CE} = 8 \text{ V}$ | h_{FE} | 50 | 100 | 200 | - |

Electrical Characteristics at $T_A = 25^\circ\text{C}$, unless otherwise specified.

| Parameter | Symbol | Values | | | Unit |
|--|---------------|--------|--------------|------|------|
| | | min. | typ. | max. | |
| AC Characteristics | | | | | |
| Transition frequency $I_C = 10 \text{ mA}$, $V_{CE} = 8 \text{ V}$, $f = 500 \text{ MHz}$ | f_T | 6 | 8 | - | GHz |
| Collector-base capacitance $V_{CB} = 10 \text{ V}$, $f = 1 \text{ MHz}$ | C_{cb} | - | 0.21 | 0.4 | pF |
| Collector-emitter capacitance $V_{CE} = 10 \text{ V}$, $f = 1 \text{ MHz}$ | C_{ce} | - | 0.27 | - | |
| Emitter-base capacitance $V_{EB} = 0.5 \text{ V}$, $f = 1 \text{ MHz}$ | C_{eb} | - | 0.32 | - | |
| Noise figure $I_C = 2 \text{ mA}$, $V_{CE} = 8 \text{ V}$, $Z_S = Z_{Sopt}$ $f = 900 \text{ MHz}$ $f = 1.8 \text{ GHz}$ | F | - | 1.45 1.8 | - | dB |
| Power gain ¹⁾ $I_C = 5 \text{ mA}$, $V_{CE} = 8 \text{ V}$, $Z_S = Z_{Sopt}$ $Z_L = Z_{Lopt}$ $f = 900 \text{ MHz}$ $f = 1.8 \text{ GHz}$ | G_{ms} | - | 20 16.5 | - | |
| Transducer gain $I_C = 5 \text{ mA}$, $V_{CE} = 8 \text{ V}$, $Z_S = Z_L = 50 \Omega$ $f = 900 \text{ MHz}$ $f = 1.8 \text{ GHz}$ | $ S_{21e} ^2$ | - | 16.5 11.5 | - | |

1) $G_{ms} = |S_{21}/S_{12}|$

SPICE Parameters (Gummel-Poon Model, Berkeley-SPICE 2G.6 Syntax) :

Transistor Chip Data

| | | | | | | | | |
|-------|-----------------|-------|-----------|-----------------|-------|-----------|-----------------|----|
| IS = | 0.0010519 fA | BF = | 96.461 | - | NF = | 0.90617 | - | |
| VAF = | 22.403 V | IKF = | 0.12146 A | | ISE = | 12.603 fA | | |
| NE = | 1.7631 | - | BR = | 16.504 | - | NR = | 0.87757 | - |
| VAR = | 5.1127 V | | IKR = | 0.24951 A | | ISC = | 0.01195 fA | |
| NC = | 1.6528 | - | RB = | 9.9037 Ω | | IRB = | 0.69278 mA | |
| RBM = | 6.6315 Ω | | RE = | 2.1372 Ω | | RC = | 2.2171 Ω | |
| CJE = | 1.8168 fF | | VJE = | 0.73155 V | | MJE = | 0.43619 | - |
| TF = | 17.028 ps | | XTF = | 0.33814 | - | VTF = | 0.12571 V | |
| ITF = | 1.0549 mA | | PTF = | 0 | deg | CJC = | 319.69 fF | |
| VJC = | 1.1633 V | | MJC = | 0.30013 | - | XCJC = | 0.082903 | - |
| TR = | 2.7449 ns | | CJS = | 0 | fF | VJS = | 0.75 | V |
| MJS = | 0 | - | XTB = | 0 | - | EG = | 1.11 | eV |
| XTI = | 3 | - | FC = | 0.99768 | - | TNOM | 300 | K |

All parameters are ready to use, no scaling is necessary.

Extracted on behalf of SIEMENS Small Signal Semiconductors by:
 Institut für Mobil-und Satellitenfunktechnik (IMST)

© 1996 SIEMENS AG

Package Equivalent Circuit:

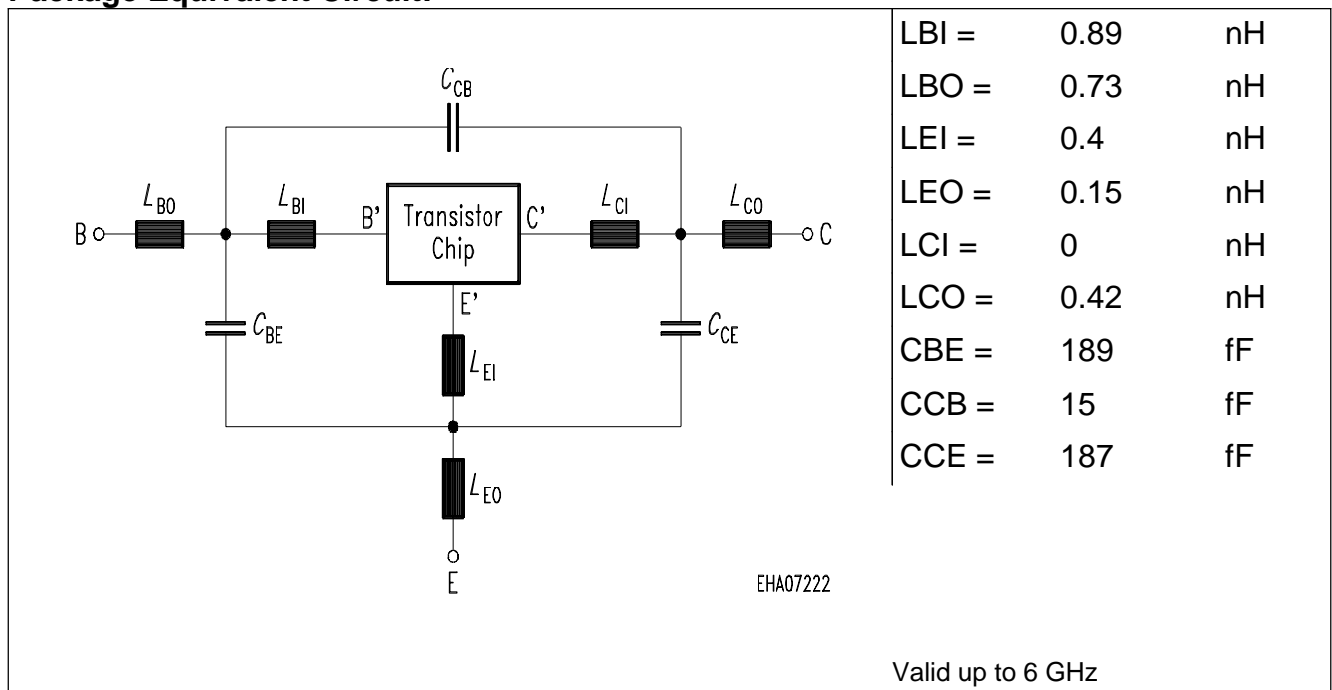

For examples and ready to use parameters please contact your local Siemens distributor or sales office to obtain a Siemens CD-ROM or see Internet: <http://www.siemens.de/Semiconductor/products/35/35.htm>

Total power dissipation $P_{tot} = f(T_A^*, T_S)$

* Package mounted on epoxy

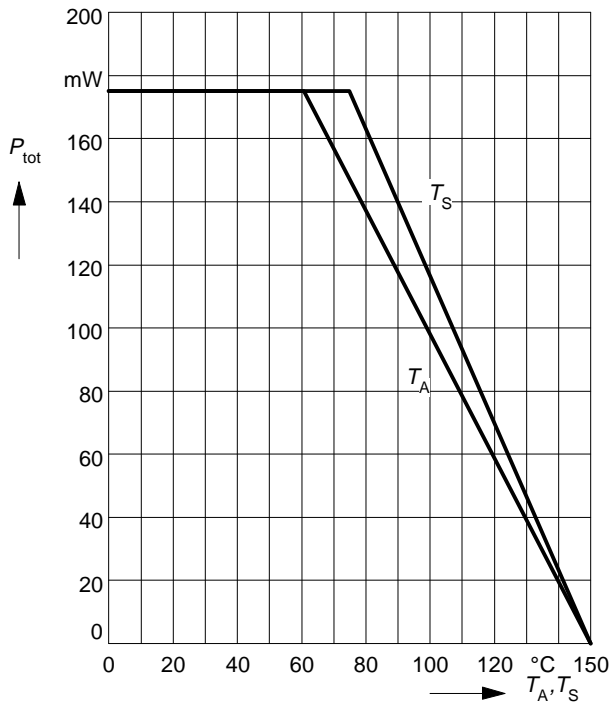

Permissible Pulse Load $R_{thJS} = f(t_p)$

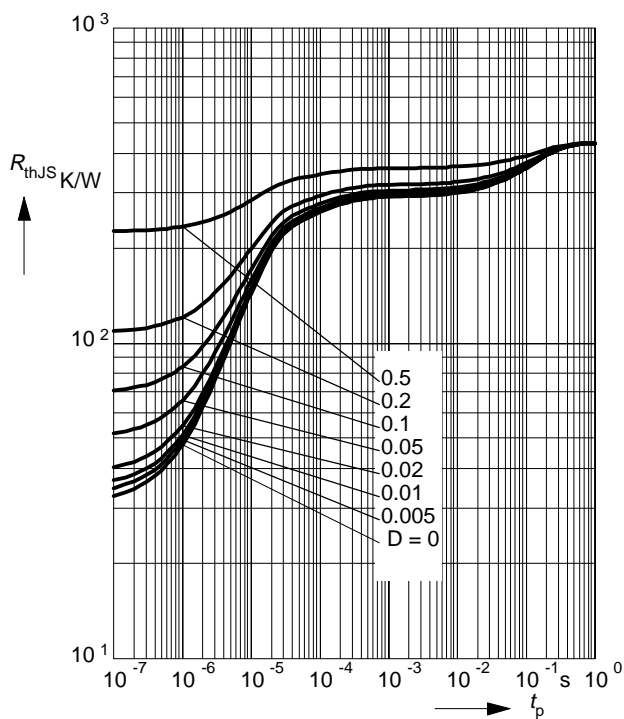

Permissible Pulse Load $P_{totmax}/P_{totDC} = f(t_p)$

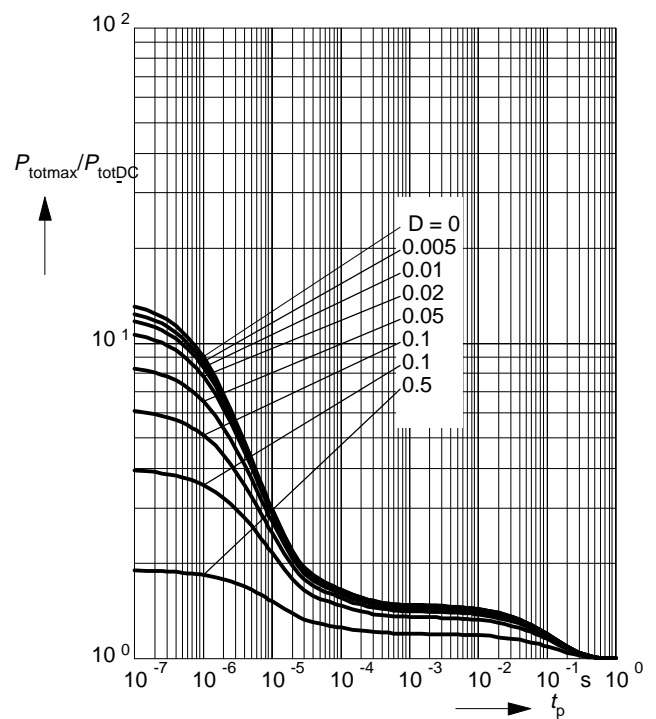

Collector-base capacitance $C_{cb} = f(V_{CB})$

$V_{BE} = v_{be} = 0, f = 1\text{MHz}$

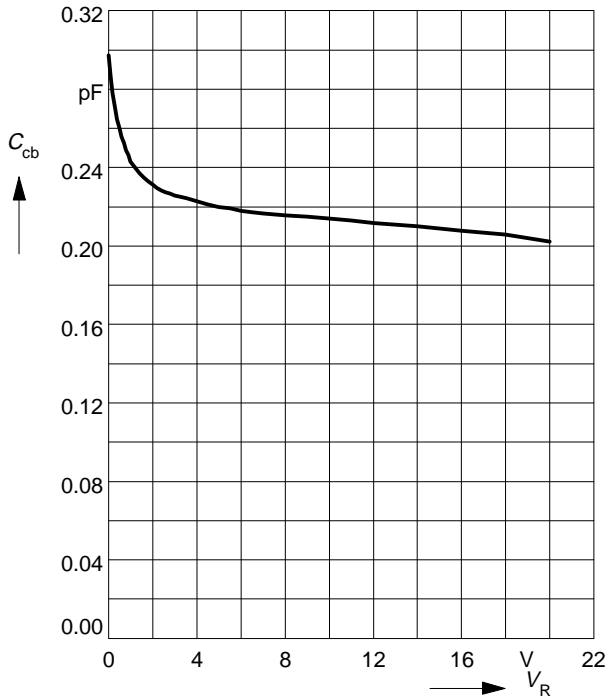

Transition frequency $f_T = f(I_C)$

$V_{CE} = \text{Parameter}$

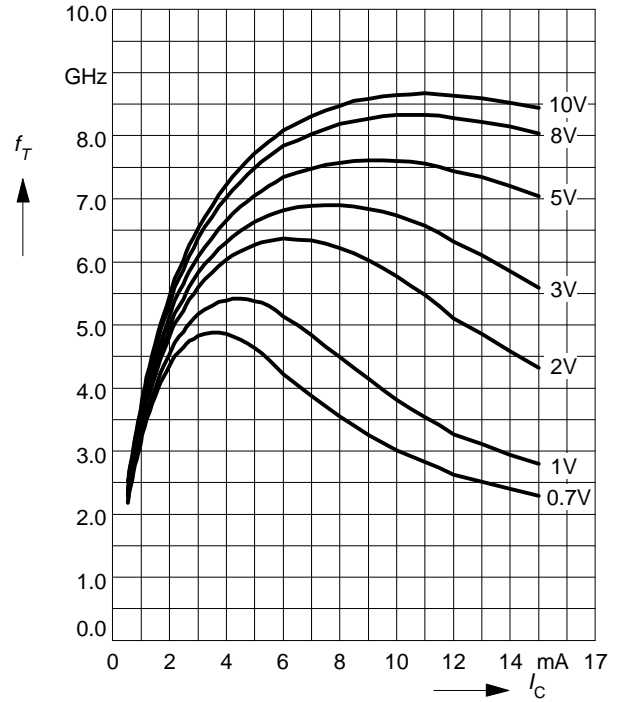

Power Gain $G_{ma}, G_{ms} = f(I_C)$

$f = 0.9\text{GHz}$

$V_{CE} = \text{Parameter}$

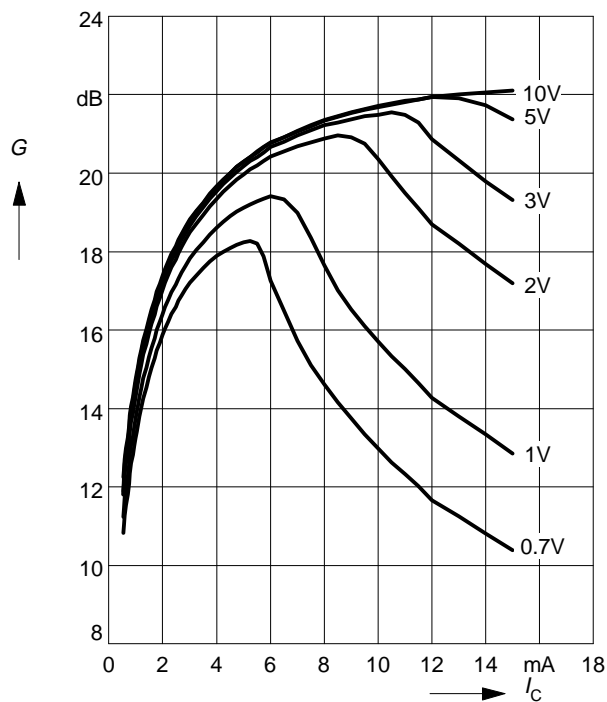

Power Gain $G_{ma}, G_{ms} = f(I_C)$

$f = 1.8\text{GHz}$

$V_{CE} = \text{Parameter}$

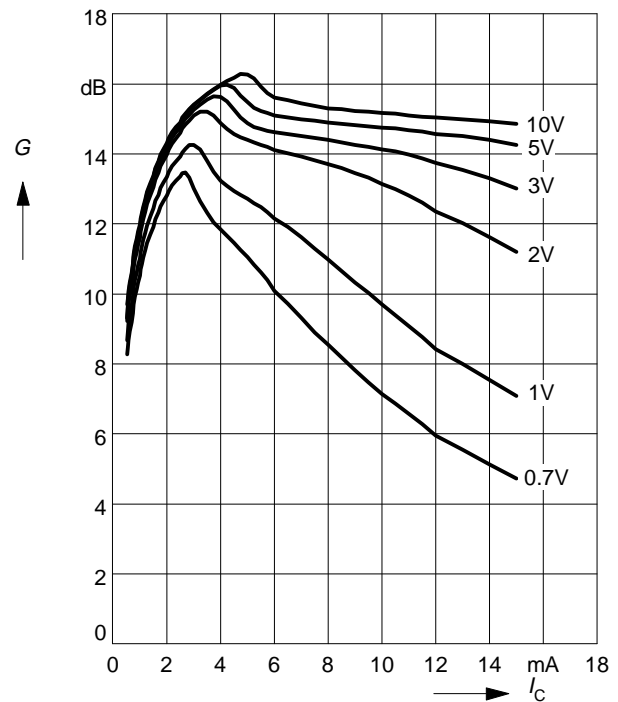

Power Gain $G_{ma}, G_{ms} = f(V_{CE})$: _____

$|S_{21}|^2 = f(V_{CE})$: - - - - -

$f =$ Parameter

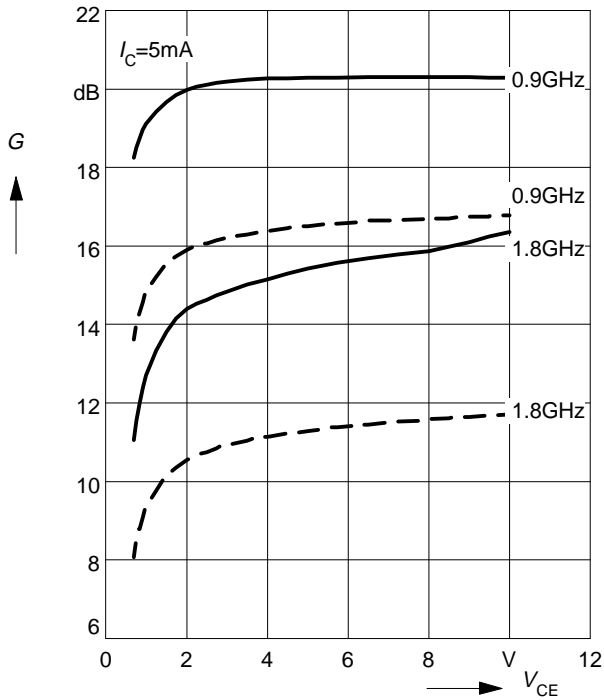

Intermodulation Intercept Point $IP_3 = f(I_C)$

(3rd order, Output, $Z_S = Z_L = 50\Omega$)

$V_{CE} =$ Parameter, $f = 900\text{MHz}$

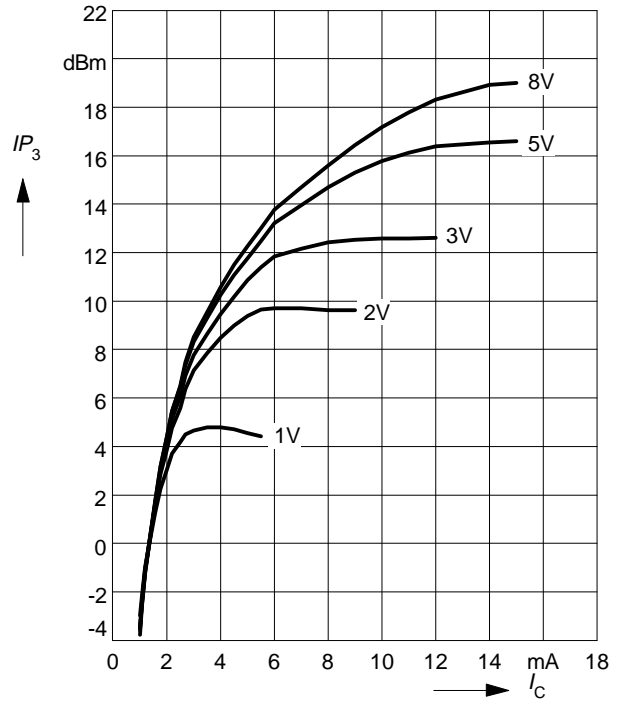

Power Gain $G_{ma}, G_{ms} = f(f)$

$V_{CE} =$ Parameter

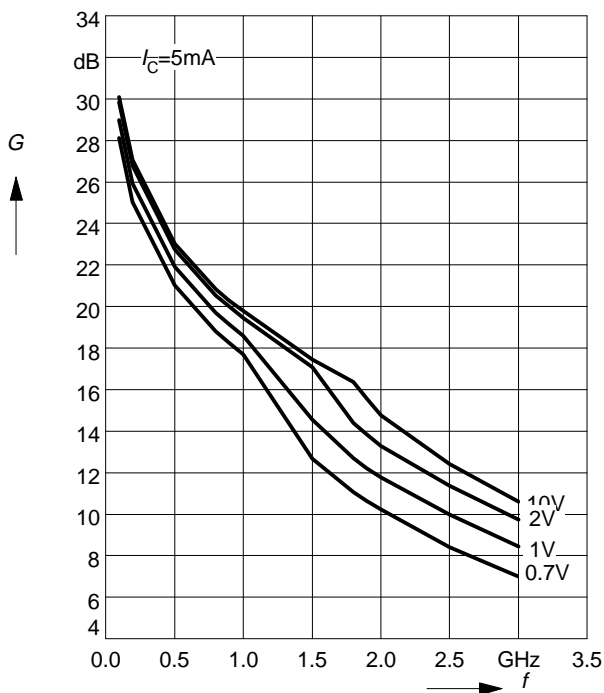

Power Gain $|S_{21}|^2 = f(f)$

$V_{CE} =$ Parameter

