

Features

- Operating voltage: 2.7V~5.5V
- LCD driving voltage: 3.0V~5.2V
- Applicable LCD duty from 1/8 to 1/16
- Suitable for various types of LCD panel
- Bias voltage adjustable from an external source

Applications

- Interface with HT163A
- Electronic dictionaries
- Portable computers
- Remote controllers
- Calculators

General Description

The HT1602L is a dot matrix LCD segment driver LSI implemented in CMOS technology. The chip contains 40-bit shift register (two 20-bit shift registers), 40-bit latch (two 20-bit latches), 40-bit level shifter, 40-bit 4-level driver and control circuits.

The HT1602L can convert serial data received from an LCD controller parallel data and then

send them out as LCD driving waveforms to the LCD panel. The chip is applicable up to 1/16 duty. Furthermore, the bias voltage which determines the LCD driving voltage can be optionally supplied from an external source, thus the chip is suitable for driving various LCD panel. These special features increase the versatility of the chip.

Block Diagram

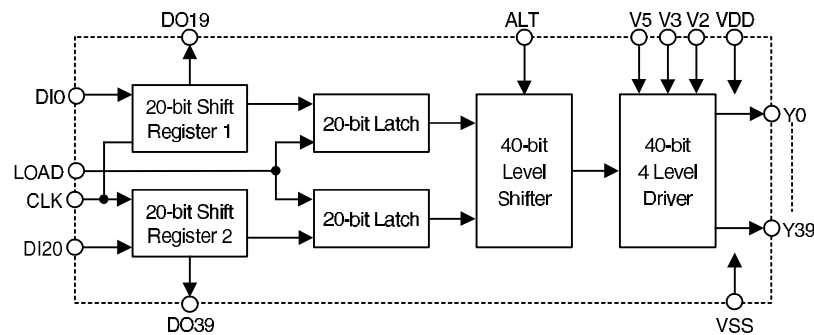

Pad Assignment

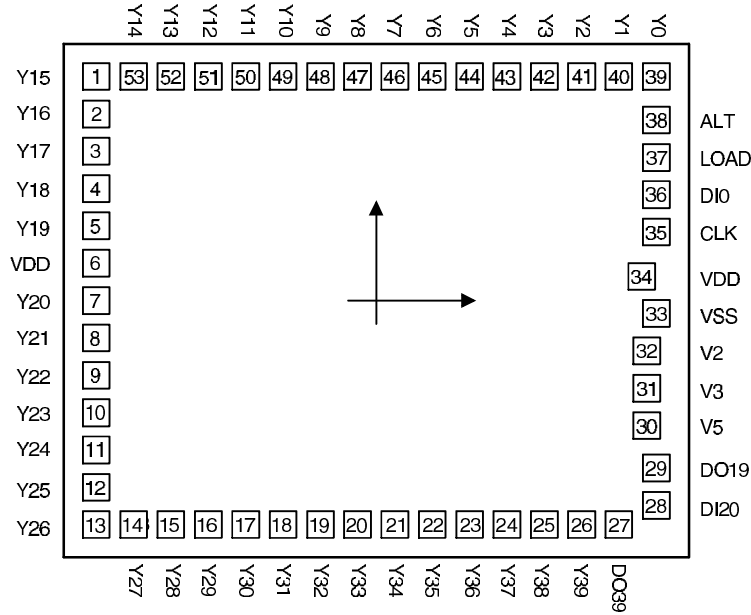

Chip size: 87 × 74 (mil)²

* The IC substrate should be connected to VSS in the PCB layout artwork.

Pad Coordinates

Unit: μm

Pad No.	X	Y	Pad No.	X	Y
1	-975.00	780.00	28	975.00	-713.00
2	-975.00	650.00	29	975.00	-583.00
3	-975.00	520.00	30	942.50	-435.50
4	-975.00	390.00	31	942.50	-305.50
5	-975.00	260.00	32	942.50	-175.50
6	-975.00	130.00	33	975.00	-45.50
7	-975.00	0.00	34	923.50	84.50
8	-975.00	-130.00	35	975.00	239.00
9	-975.00	-260.00	36	975.00	369.00
10	-975.00	-390.00	37	975.00	499.00
11	-975.00	-520.00	38	975.00	629.00
12	-975.00	-650.00	39	975.00	780.00
13	-975.00	-780.00	40	845.00	780.00
14	-845.00	-780.00	41	715.00	780.00
15	-715.00	-780.00	42	585.00	780.00
16	-585.00	-780.00	43	455.00	780.00

Pad No.	X	Y	Pad No.	X	Y
17	-455.00	-780.00	44	325.00	780.00
18	-325.00	-780.00	45	195.00	780.00
19	-195.00	-780.00	46	65.00	780.00
20	-65.00	-780.00	47	-65.00	780.00
21	65.00	-780.00	48	-195.00	780.00
22	195.00	-780.00	49	-325.00	780.00
23	325.00	-780.00	50	-455.00	780.00
24	455.00	-780.00	51	-585.00	780.00
25	585.00	-780.00	52	-715.00	780.00
26	715.00	-780.00	53	-845.00	780.00
27	845.00	-780.00			

Pad Description

Pad No.	Pad Name	I/O	Description
1~5	Y15~Y19	O	LCD driver output for segment*
6	VDD	—	Power supply (positive)
7~26	Y20~Y39	O	LCD driver output for segment
27	DO39	O	Shift register output pad for the 40th bit data
28	DI20	I	Data input pad of shift register 2
29	DO19	O	Shift register output pad for the 20th bit data
30, 31, 32	V5, V3, V2	I	LCD bias supply voltage
33	VSS	—	Power supply (ground)
34	VDD	—	Power supply (positive)
35	CLK	I	Clock pulse input pad for the shift register
36	DI0	I	Data input pad of shift register 1
37	LOAD	I	Latching signal to latch shift register data
38	ALT	I	Alternate signal input pad for LCD driving waveform
39~53	Y0~Y14	O	LCD driver output for segment*

*: For Y0~Y39, one of VDD, V2, V3 or V5 is selected as a display driving source according to the combination of latched data level and ALT signal. Refer to the following table:

Latched Data	ALT	Display data output level
H	H	V5
	L	VDD
L	H	V3
	L	V2

Absolute Maximum Ratings*

Supply Voltage -0.3V to 6.0V Storage Temperature..... -50°C to 125°C
 Input Voltage..... $V_{SS}-0.3V$ to $V_{DD}+0.3V$ Operating Temperature..... -20°C to 70°C

*Note: These are stress ratings only. Stresses exceeding the range specified under “Absolute Maximum Ratings” may cause substantial damage to the device. Functional operation of this device at other conditions beyond those listed in the specification is not implied and prolonged exposure to extreme conditions may affect device reliability.

D.C. Characteristics

Ta=25°C

Symbol	Parameter	Test Conditions		Min.	Typ.	Max.	Unit
		V _{DD}	Conditions				
V _{DD}	Operating Voltage	—	—	2.7	—	5.5	V
I _{OP}	Operating Current	5V	No load	—	100	300	μA
I _{DD}	Standby Current	5V	—	—	1	5	μA
f _{LCD}	Clock Frequency	5V	—	3.3	—	—	MHz
tw _{CLK}	Clock Pulse Width	5V	—	125	—	—	ns
V _{IL}	“L” Input Voltage	5V	—	—	—	0.3V _{DD}	V
V _{IH}	“H” Input Voltage	5V	—	0.7V _{DD}	—	—	V
V _{LCD}	LCD Driving Voltage	5V	—	3	—	5.2	V

Timing Diagrams

1/16 duty and 1/5 bias

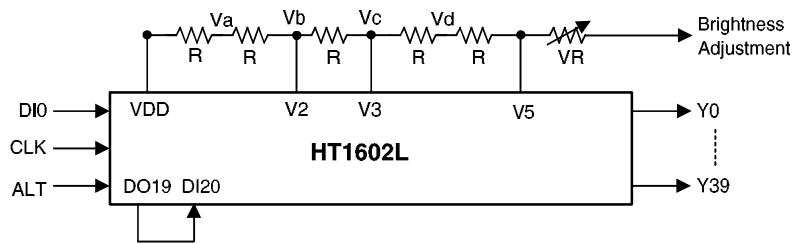
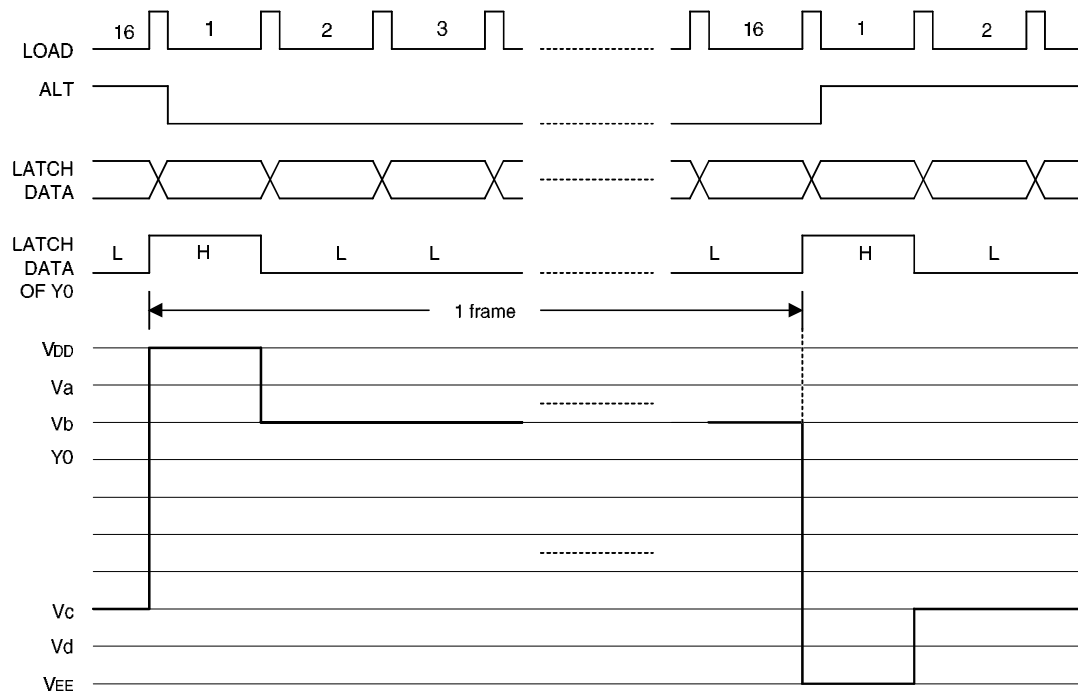

$$\begin{aligned}
 V_a &= V_{DD} - (1/5)V_{LCD} \\
 V_b &= V_{DD} - (2/5)V_{LCD} \\
 V_c &= V_{DD} - (3/5)V_{LCD} \\
 V_d &= V_{DD} - (4/5)V_{LCD} \\
 V_5 &= V_{DD} - V_{LCD} \\
 V_{LCD} &= V_{DD} - V_5; \text{ LCD driving voltage}
 \end{aligned}$$

Application Circuits

