



---

---

**16 Bits Shift Register Latched Constant Current Driver IC**

**PT6957**

---

---

## DESCRIPTION

PT6957 is an LED Driver IC utilizing CMOS Technology used to unify the luminance of the LED panel. It is equipped with 16 bits Shift Register and Latched Constant Current Driver, Serial I/O interface for multiple chips, Cascading and Serial Input, Parallel Output for LED Interface. Pin assignments and application circuits are optimized for easy PCB layout and cost saving advantages.

## FEATURES

- CMOS Technology
- Serial I/O, Parallel Output Interface
- Cascade Extension
- Constant Current Output (adjustable by external resistor for 0 to 30mA)
- Output-enabled Control (ENA, ENB)
- Available in 28-pin, SO Package

## APPLICATION

- LED Panel Driver



16 Bits Shift Register Latched Constant Current Driver IC

PT6957

PIN CONFIGURATION

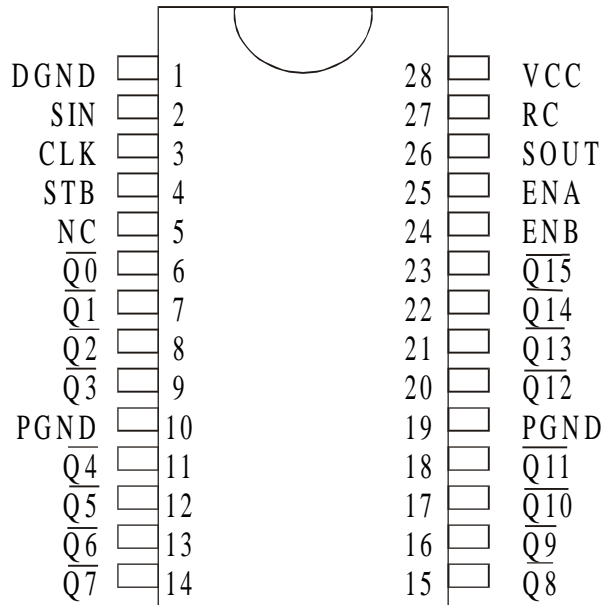

ORDER INFORMATION

Part Number	Package Type
PT6957	28-Pin, SO Package (300 mil)



16 Bits Shift Register Latched Constant Current Driver IC

PT6957

APPLICATION CIRCUIT 1

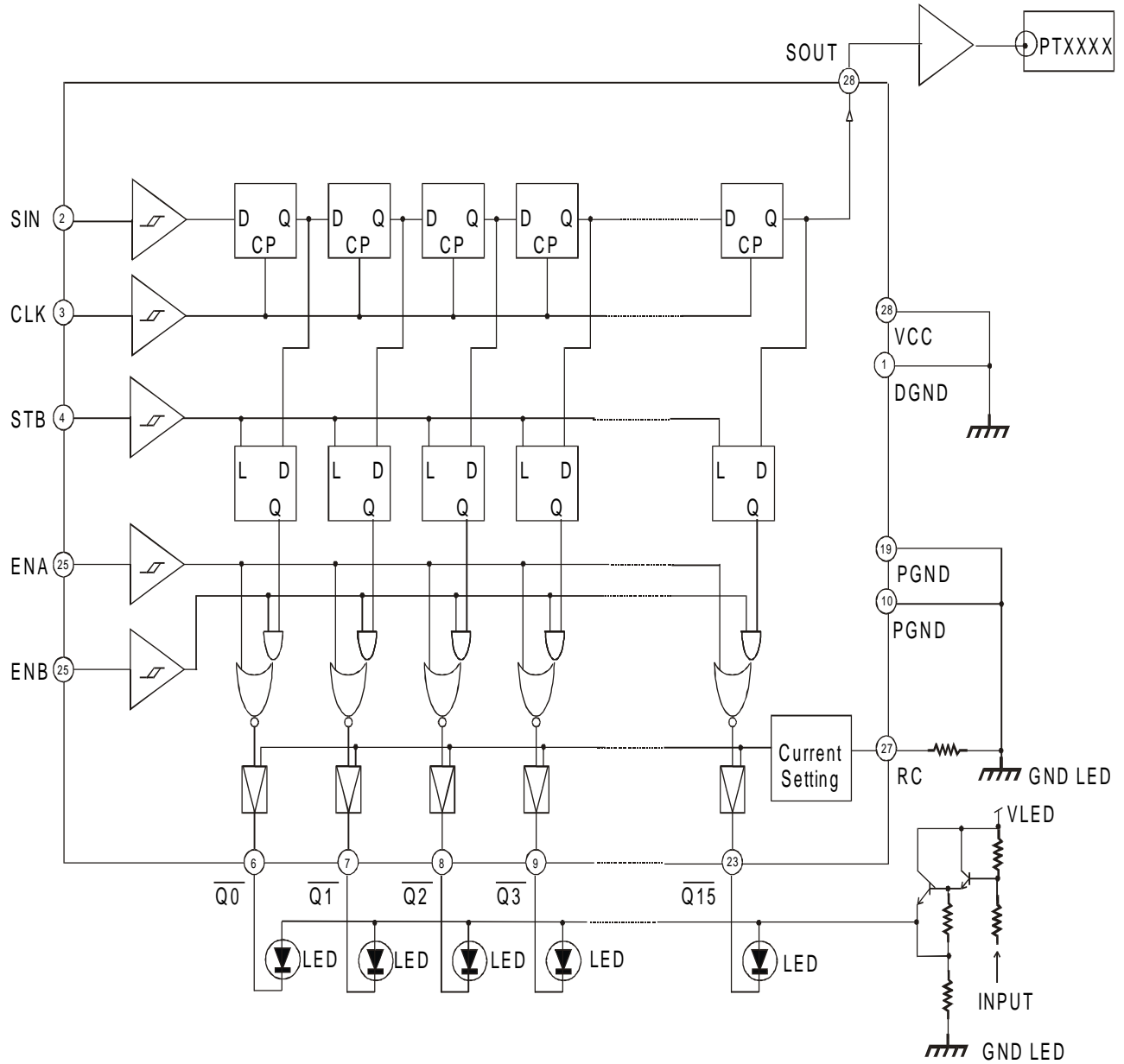

Note: VLED= External Power Supply (Maximum Value=7V)