

MS2284

**RF & MICROWAVE TRANSISTORS
 AVIONICS APPLICATION**

Features

- 60 W (MIN) POWER OUTPUT @ 1030 MHz
- 10 dB GAIN
- LOW THERMAL RESISTANCE
- BALLASTED GEOMETRY
- INPUT MATCHED
- VSWR 20:1 CAPABILITY @ RATED CONDITIONS
- COMMON BASE CONFIGURATION

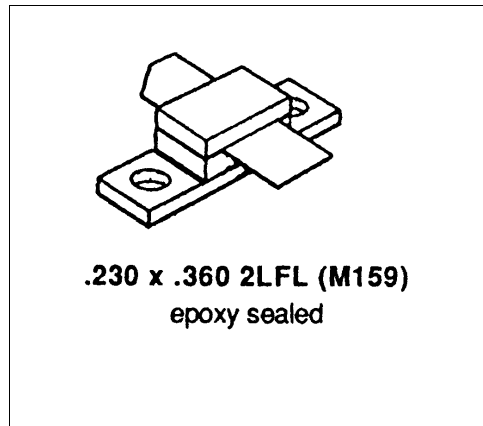

DESCRIPTION:

THE MS2284 IS DESIGNED FOR 1030/1090 MHz IFF APPLICATIONS. THE MS2284 CAN BE OPERATED AT DUTY CYCLES UP TO 10% WITH MINIMAL DERATING OF POWER OUTPUT (40W TYPICAL).

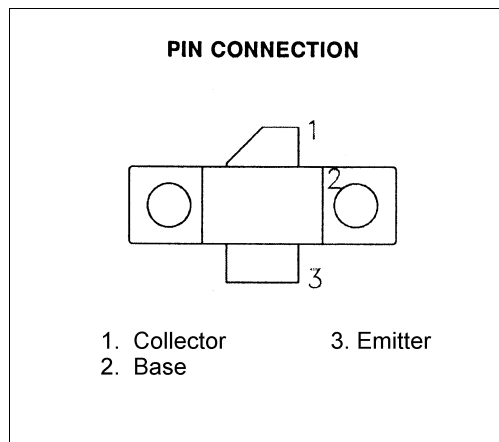

ABSOLUTE MAXIMUM RATINGS (T_{case} = 25°C)

Symbol	Parameter	Value	Unit
P _{DISS}	Power Dissipation*	140	W
I _C	Device Current *	3	A
V _{CC}	Collector Supply Voltage*	55	V
T _J	Junction Temperature	200	°C
T _{STG}	Storage Temperature	-65 to +150	°C

* Operating Conditions

Thermal Data

R _{TH(J-C)}	Junction - Case Thermal Resistance	0.7	°C/W
----------------------	------------------------------------	-----	------

ELECTRICAL SPECIFICATIONS (Tcase = 25°C)

STATIC

Symbol	Test Conditions	Value			Unit
		Min.	Typ.	Max.	
Bvebo	I _C = 1 mA	3.5	---	---	V
Bvcbo	I _C = 10 mA	65	---	---	V
Ices	V _{CE} = 50 mA	---		2	mA
HFE	V _{CE} = 5.0 V I _C = 1 A	20	---	120	B

DYNAMIC

Symbol	Test Conditions	Value			Unit
		Min.	Typ.	Max.	
P _{out}	f=1030 MHz P _{in} =6.0W V _{CC} =50V	60	---	---	W
η _c	f=1030 MHz P _{in} =6.0W V _{CC} =50V	35	---	---	%
G _p	f=1030 MHz P _{in} =6.0W V _{CC} =50V	10	---	---	dB
Conditions	Pulse width=10μsec, Duty Cycle= 1%				

PACKAGE MECHANICAL DATA

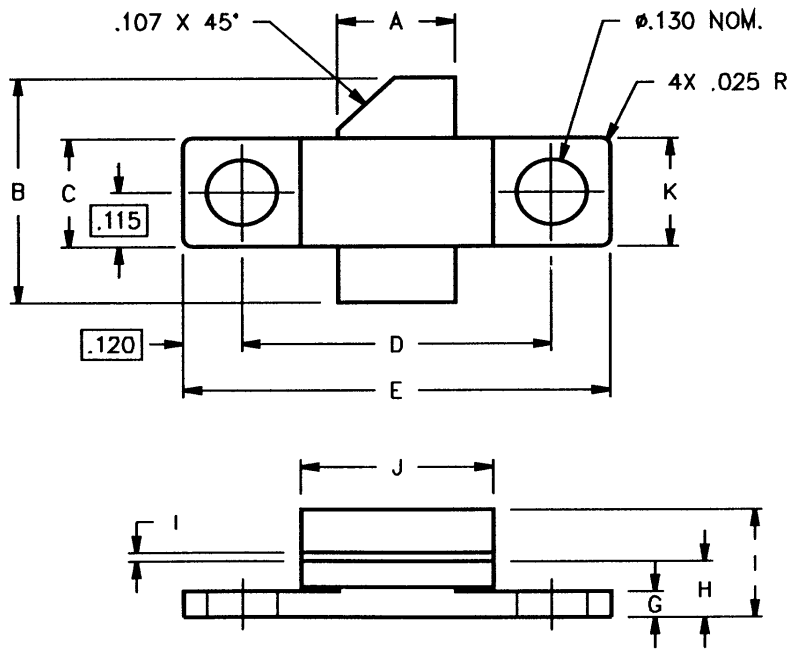

	MINIMUM INCHES/MM	MAXIMUM INCHES/MM		MINIMUM INCHES/MM	MAXIMUM INCHES/MM
A	.210/5,33	.220/5,51	I		.240/6,10
B	.670/17,02	.730/18,54	J	.355/9,02	.365/9,27
C	.225/5,72	.235/5,97	K	.225/5,72	.235/5,97
D	.555/14,10	.565/14,35			
E	.795/20,19	.805/20,45			
F	.003/0,08	.007/0,18			
G	.039/1,00	.050/1,27			
H	.120/3,05	.135/3,43			