

TOSHIBA TRANSISTOR SILICON NPN EPITAXIAL PLANAR TYPE

2SC3122

TV VHF RF AMPLIFIER APPLICATIONS

Unit in mm

- High Gain : $G_{pe} = 24\text{dB}$ (Typ.) ($f = 200\text{MHz}$)
- Low Noise : $NF = 2.0\text{dB}$ (Typ.) ($f = 200\text{MHz}$)
- Excellent Forward AGC Characteristics

MAXIMUM RATINGS ($T_a = 25^\circ\text{C}$)

CHARACTERISTIC	SYMBOL	RATING	UNIT
Collector-Base Voltage	V_{CBO}	30	V
Collector-Emitter Voltage	V_{CEO}	30	V
Emitter-Base Voltage	V_{EBO}	3	V
Collector Current	I_C	20	mA
Base Current	I_B	10	mA
Collector Power Dissipation	P_C	150	mW
Junction Temperature	T_j	125	$^\circ\text{C}$
Storage Temperature Range	T_{stg}	-55~125	$^\circ\text{C}$

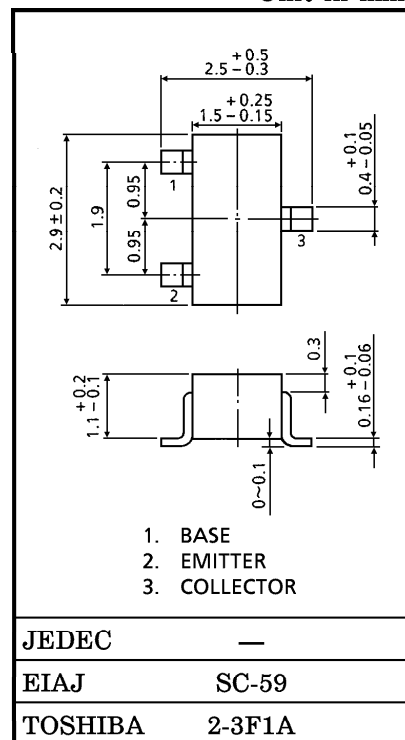

Weight : 0.012g

Marking

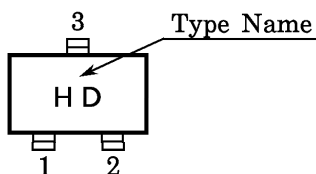

ELECTRICAL CHARACTERISTICS ($T_a = 25^\circ\text{C}$)

CHARACTERISTIC	SYMBOL	TEST CONDITION	MIN.	TYP.	MAX.	UNIT
Collector Cut-off Current	I_{CBO}	$V_{CB} = 25\text{V}, I_E = 0$	—	—	100	nA
Emitter Cut-off Current	I_{EBO}	$V_{EB} = 2\text{V}, I_C = 0$	—	—	100	nA
Collector-Emitter Breakdown Voltage	$V_{(BR)CEO}$	$I_C = 1\text{mA}, I_B = 0$	30	—	—	V
DC Current Gain	h_{FE}	$V_{CE} = 10\text{V}, I_C = 2\text{mA}$	60	150	300	—
Reverse Transfer Capacitance	C_{re}	$V_{CB} = 10\text{V}, I_E = 0, f = 1\text{MHz}$	—	0.3	0.45	pF
Transition Frequency	f_T	$V_{CE} = 10\text{V}, I_C = 2\text{mA}$	400	650	—	MHz
Power Gain	G_{pe}	$V_{CE} = 12\text{V}, V_{AGC} = 1.4\text{V}, f = 200\text{MHz}$	20	24	28	dB
Noise Figure	NF	$f = 200\text{MHz}$	—	2.0	3.2	dB
AGC Voltage	V_{AGC}	$V_{CC} = 12\text{V}, GR = 30\text{dB}, f = 200\text{MHz}$ (Note)	3.6	4.4	5.1	V

(Note) V_{AGC} measured by test circuit shown in Fig.1 when power gain is reduced to 30dB compared that of V_{AGC} at 1.4V.

961001EAA2

- TOSHIBA is continually working to improve the quality and the reliability of its products. Nevertheless, semiconductor devices in general can malfunction or fail due to their inherent electrical sensitivity and vulnerability to physical stress. It is the responsibility of the buyer, when utilizing TOSHIBA products, to observe standards of safety, and to avoid situations in which a malfunction or failure of a TOSHIBA product could cause loss of human life, bodily injury or damage to property. In developing your designs, please ensure that TOSHIBA products are used within specified operating ranges as set forth in the most recent products specifications. Also, please keep in mind the precautions and conditions set forth in the TOSHIBA Semiconductor Reliability Handbook.
- The information contained herein is presented only as a guide for the applications of our products. No responsibility is assumed by TOSHIBA CORPORATION for any infringements of intellectual property or other rights of the third parties which may result from its use. No license is granted by implication or otherwise under any intellectual property or other rights of TOSHIBA CORPORATION or others.
- The information contained herein is subject to change without notice.

Fig.1 200MHz G_{pe} , NF TEST CIRCUIT

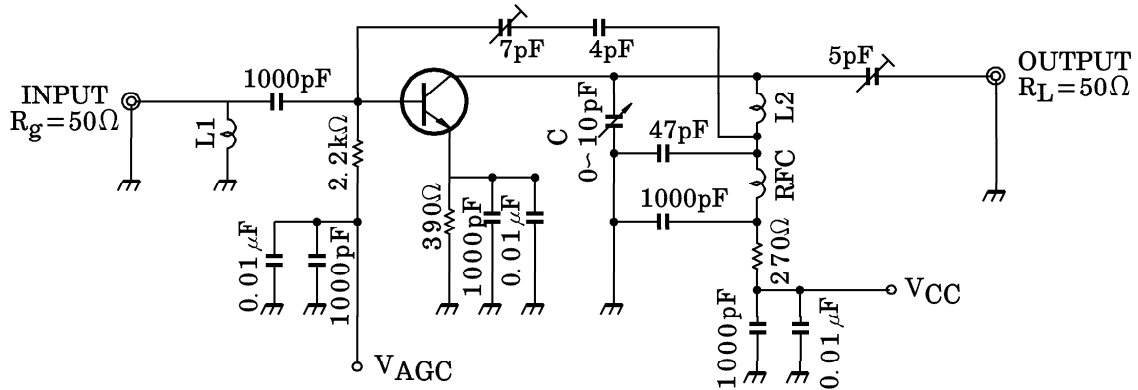

L1 : RF Coil M-15T (TOKO Inc.) or EQUIVALENT
 L2 : RF Coil M-25T (TOKO Inc.) or EQUIVALENT

