

**CURRENT MODE PWM CONTROLLER**

The KA3882/3/4/5 are fixed PWM controller for Off-Line and DC to DC converter applications. The internal circuits include UVLO, low start up current circuit, temperature compensated reference, high gain error amplifier, current sensing comparator, and high current totempole output for driving a POWER MOSFET. Also KA 3882/3/4/5 provide low start up current below 0.3mA and short shutdown delay time typ. 100ns.

The KA3882 and KA3884 have UVLO threshold of 1.6V(on) and 10V(off).

The KA3883 and KA3885 are 8.4V(on) and 7.6V(off).

The KA3882 and KA3883 can operate within 100% duty cycle.

The KA3884 and KA3885 within 50% by using T Flip-Flop.

**FEATURES**

- Low Start Current 0.2mA (typ)
- Operating Range Up To 500KHz
- Cycle by Cycle Current Limiting
- Under Voltage Lock Out With Hysteresis
- Short Shutdown Delay Time: typ.100ns
- High Current Totempole Output
- Output Swing Limiting: 22V

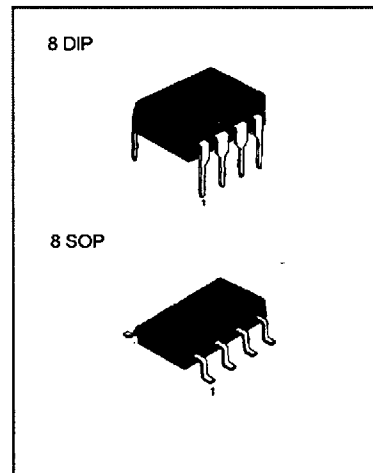

**ORDERING INFORMATION**

Device	Package	Operating Temperature
KA388X	8 DIP	0 ~ + 85°C
KA388XD	8 SOP	0 ~ + 85°C

**BLOCK DIAGRAM**

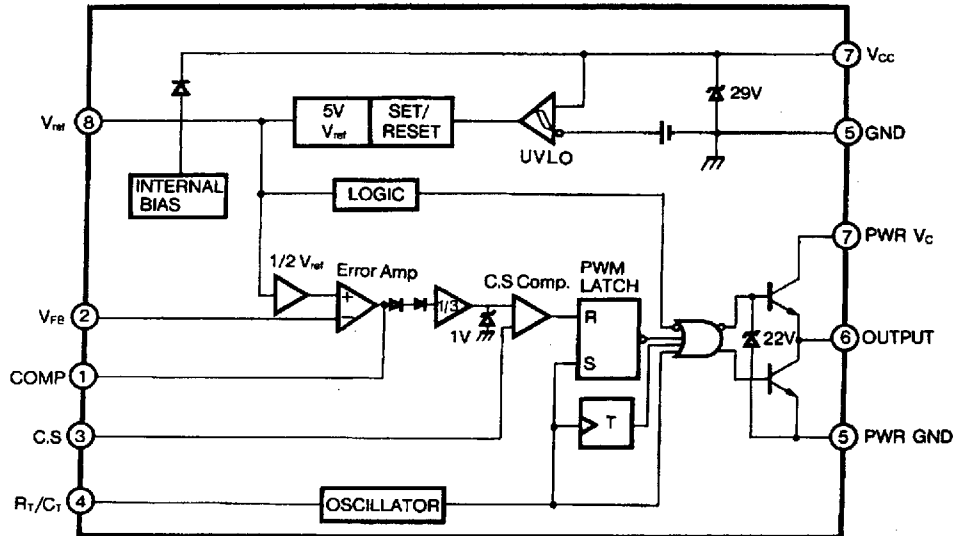

**ABSOLUTE MAXIMUM RATINGS**

Characteristic	Symbol	Value	Unit
Supply Voltage	$V_{CC}$	30	V
Output Current	$I_o$	+ 1	A
Analog Inputs (pin 2, 3)	$V_{I(ANA)}$	- 0.3 to 6.3	V
Error Amp. Output Sink Current	$I_{SINK(EA)}$	10	mA
Power Dissipation	$P_D$	1	W

**ELECTRICAL CHARACTERISTICS**

( $V_{CC} = 15V$ ,  $R_T = 10K\Omega$ ,  $C_T = 3.3nF$ ,  $T_A = 0^\circ C$  to  $+ 85^\circ C$ , Unless otherwise specified)

Characteristic	Symbol	Test Conditions	Min	Typ	Max	Unit
<b>REFERENCE SECTION</b>						
Output Voltage	$V_{REF}$	$T_J = 25^\circ C$ , $I_o = 1mA$	4.9	5.0	5.1	V
Line Regulation	$\Delta V_{REF}$	$V_{CC} = 12V$ to $25V$	—	6	20	mV
Load Regulation	$\Delta V_{REF}$	$I_o = 1mA$ to $20mA$	—	6	25	mV
Output Short Circuit	$I_{SC}$	$T_a = 25^\circ C$	—	- 100	- 180	mA
<b>OSILLATOR SECTION</b>						
Initial Accuracy	$F_{OSC}$	$T_J = 25^\circ C$	47	52	57	KHz
Voltage Stability	$ST_V$	$V_{CC} = 12V$ to $25V$	—	0.2	1	%
Amplitude	$V_{OSC}$	$V_{PIN4}$ , Peak to Peak	—	1.7	—	V
Discharge Current	$I_{DISCHG}$	$T_J = 25^\circ C$ , $Pin4 = 2V$	7.8	8.3	8.8	mA
<b>CURRENT SENSE SECTION</b>						
Gain	$G_V$	(NOTE 2, 3)	2.85	3	3.15	V/V
Maximum Input Signal	$V_{I(MAX)}$	$V_{PIN1} = 5V$ (NOTE 2)	0.9	1.0	1.1	V
PSRR	PSRR	$V_{CC} = 12V$ to $25V$ (NOTE 1, 2)	—	70	—	dB
Input Bias Current	$I_{BIAS}$	—	—	- 2	-10	$\mu A$
Delay to Output	$T_D$	$V_{PIN3} = 0V$ to $2V$ (NOTE1)	—	100	200	ns

**ELECTRICAL CHARACTERISTICS(Continued)**

(V<sub>CC</sub> = 15V, R<sub>T</sub> = 10KΩ, C<sub>T</sub> = 3.3nF, T<sub>A</sub> = 0°C to + 85°C, Unless otherwise specified)

Characteristic	Symbol	Test Conditions	Min	Typ	Max	Unit
<b>ERROR AMPLIFIER SECTION</b>						
Input Voltage	V <sub>I</sub>	T <sub>PIN1</sub> = 2.5V	2.42	2.50	2.58	V
Input Bias Current	I <sub>BIAS</sub>	—	—	-0.3	- 2	uA
Open Loop Gain	G <sub>VO</sub>	V <sub>O</sub> = 2V to 4V (NOTE 1)	65	90	—	dB
Unity Gain Bandwidth	GBW	T <sub>J</sub> = 25°C (NOTE 1)	0.7	1	—	MHz
PSRR	PSRR	V <sub>CC</sub> = 12V to 25V (NOTE 1)	60	70	—	dB
Output Sink Current	I <sub>SINK</sub>	V <sub>PIN2</sub> = 2.7V V <sub>PIN1</sub> = 1.1V	2	6	—	mA
Output Source Current	I <sub>SOURCE</sub>	V <sub>PIN2</sub> = 2.3V V <sub>PIN1</sub> = 5.0V	-0.5	-0.8	—	mA
Output High Voltage	V <sub>OH</sub>	V <sub>PIN2</sub> = 2.3V R1 = 15KΩ to GND	5	6	—	V
Output Low Voltage	V <sub>OL</sub>	V <sub>PIN2</sub> = 2.7V R1 = 15KΩ to Pin8	—	0.8	1.1	V
<b>OUTPUT SECTION</b>						
Output Low Level	V <sub>OL</sub>	I <sub>SINK</sub> = 20mA	—	0.1	0.4	V
		I <sub>SINK</sub> = 200mA	—	1.5	2.2	V
Output High Level	V <sub>OH</sub>	I <sub>SOURCE</sub> = 20mA	13	13.5	—	V
		I <sub>SOURCE</sub> = 200mA	12	13.5	—	V
Rise Time	t <sub>R</sub>	T <sub>J</sub> = 25°C, C1 = 1nF (NOTE 1)	—	40	100	ns
Fall Time	t <sub>F</sub>	T <sub>J</sub> = 25°C, C1 = 1nF (NOTE 1)	—	40	100	ns
Output Voltage Swing Limit	V <sub>OLIM</sub>	V <sub>CC</sub> = 27V, C1 = 1nF	—	22	—	V
<b>UNDER VOLTAGE LOCKOUT SECTION</b>						
Start Threshold	V <sub>TH</sub>	KA3882/4	15	16	17	V
		KA3883/5	7.8	8.4	9.0	V
Min.Operating Voltage ( After turn on )	V <sub>TL</sub>	KA3882/4	9	10	11	V
		KA3883/5	7.0	7.6	8.2	V

**ELECTRICAL CHARACTERISTICS(Continued)**

(V<sub>CC</sub> = 15V, R<sub>T</sub> = 10KΩ, C<sub>T</sub> = 3.3nF, T<sub>A</sub> = 0°C to +85°C, unless otherwise specified)

Characteristic	Symbol	Test Conditions	Min	Typ	Max	Unit
<b>PWM SECTION</b>						
Maximum Duty Cycle	D <sub>MAX</sub>	KA3882/3	94	96	100	%
		KA3884/5	47	48	50	%
Minimum Duty Cycle	D <sub>MIN</sub>	—	—	—	0	%
<b>TOTAL STANDBY CURRENT</b>						
Start-Up Current	I <sub>ST</sub>	—	—	0.2	0.4	mA
Operating Supply Current	I <sub>CC</sub>	V <sub>PIN2</sub> = V <sub>PIN3</sub> = 0V	—	11	17	mA
V <sub>CC</sub> Zener Voltage	V <sub>Z</sub>	I <sub>CC</sub> = 25mA	—	29	—	V

\* Adjust V<sub>CC</sub> above the start threshold before setting at 15V

NOTE 1. These parameters, although guaranteed, are not 100% tested in production.

2. Parameter measured at trip point of latch with V<sub>2</sub> = 0V.

3. Gain defined as:  $G_V = \Delta V_{PIN1} / \Delta V_{PIN3}$  (V<sub>PIN3</sub> = 0 to 0.8V)

Dimensions in Millimeters

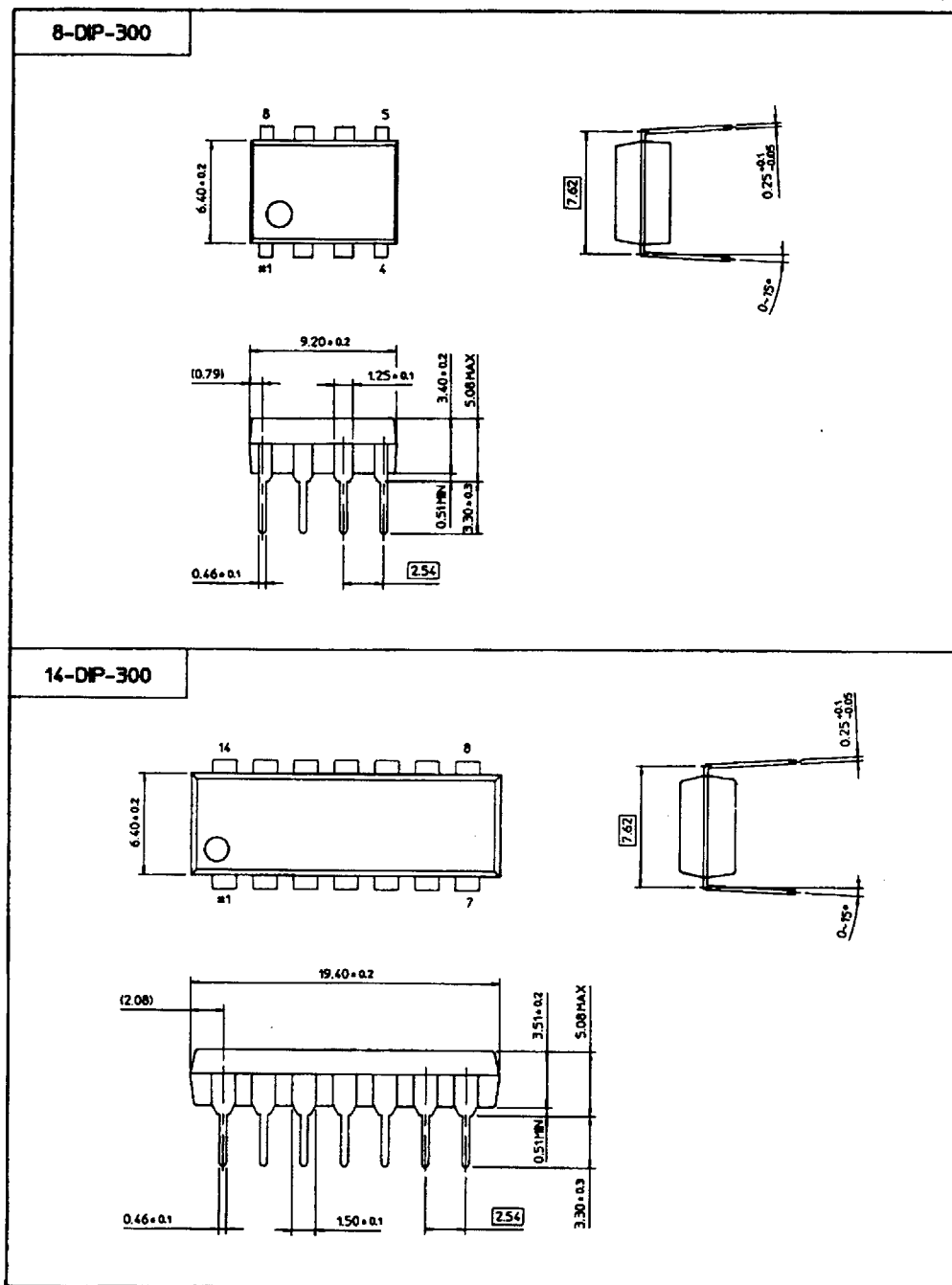

8-SOP-225

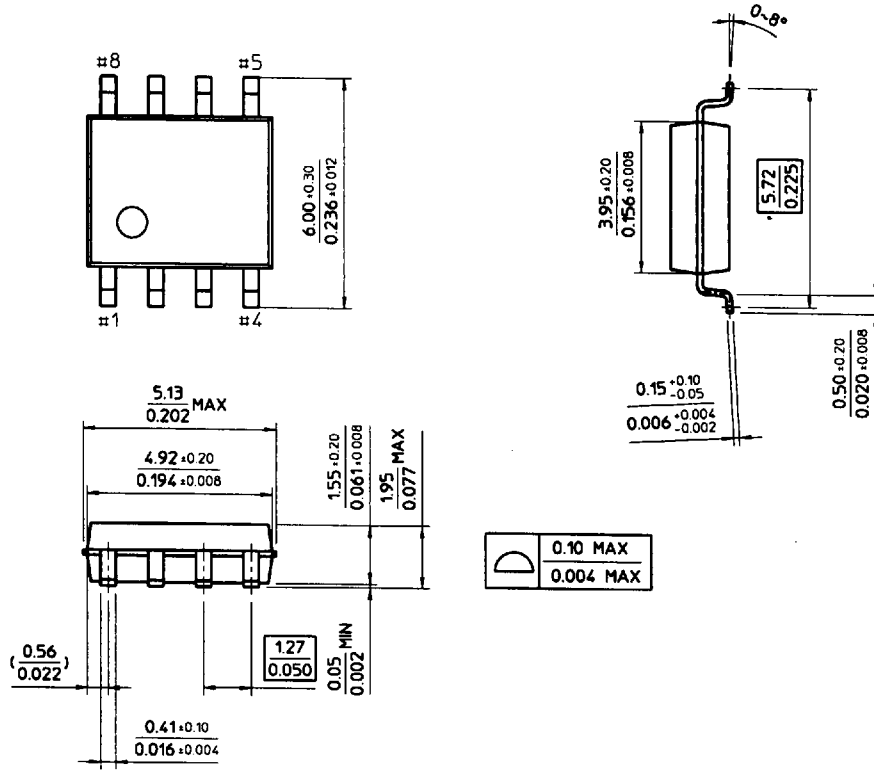

14-SOP-225B

