

General Description

The GOLD System Controller (GOLD-μC) is part of a chip set, which covers all functions of a mobile radio provided for the **G**lobal **S**ystem for **M**obile communications, GSM. A mobile terminal which contains this chip set will meet all performance requirements set down in the GSM recommendations for speech and data services.

GOLD-μC contains a 16-bit microcontroller type 80C166 with an address space being extended from 256 Kbyte to 2 Mbyte and a system interface block which comprises a series of GSM-specific interfaces and control functions.

Type	Package
PMB 2706-F	P-TQFP-144-2 (SMD)

Features

- Integrated 16-bit microcontroller (SAB 80C166) with 2-Mbyte linear address space
Complete development tooling available
- System interface with synthesizer, AGC, AFC and PA control, chip card interfacing, timing signal generation, clock generation
- Bidirectional tristate buffer
GOLD-SP can access to controller memory
- Package P-TQFP-144, 20 × 20 mm, 0.50 mm pitch
- 3-V supply voltage (± 10 %)

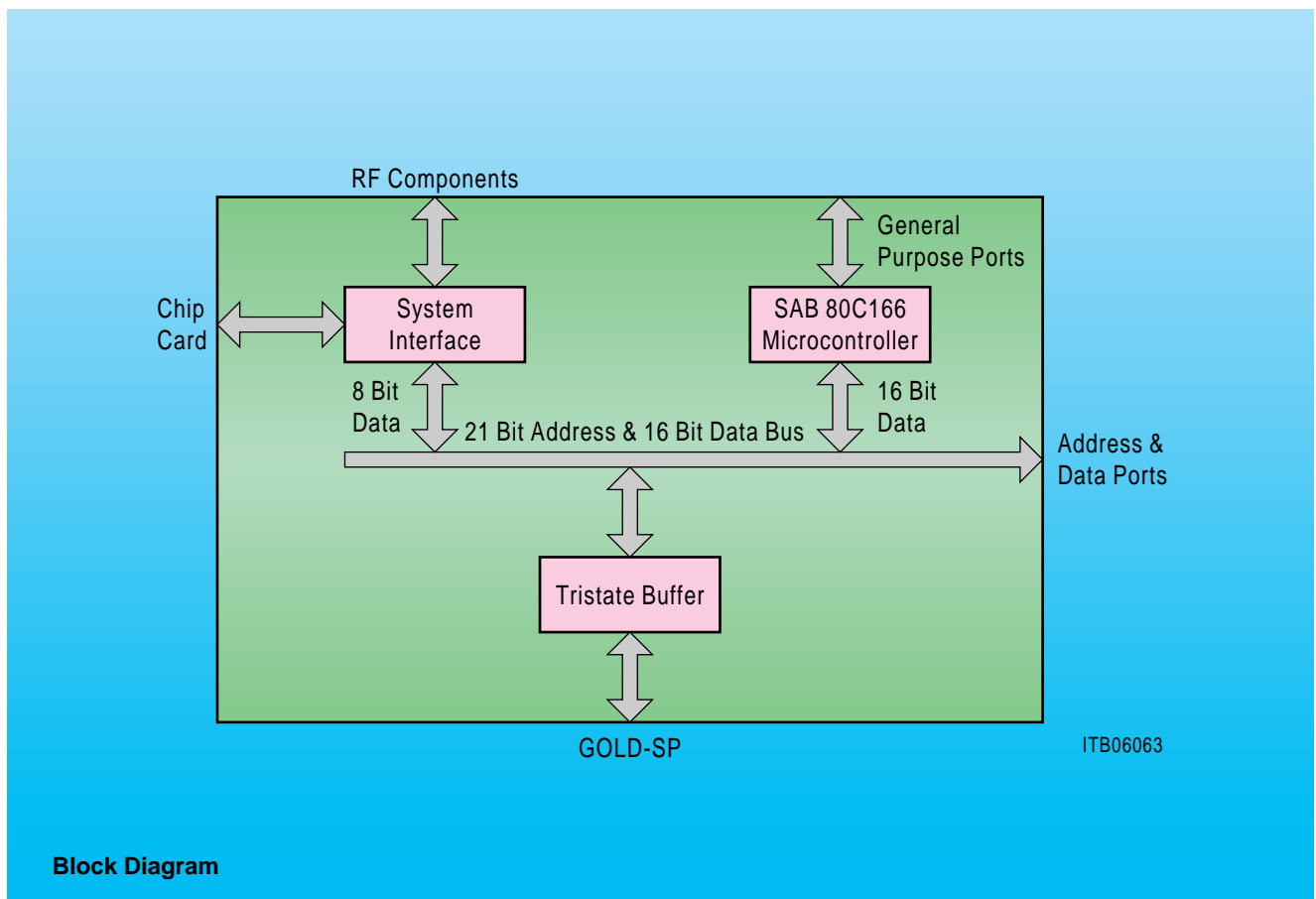

Block Diagram