



===== **CONTENTS** **=====**

1.	GENERAL DESCRIPTION	3
2.	FEATURES	3
3.	APPLICATIONS	3
4.	BLOCK DIAGRAM	4
5.	PIN ASSIGNMENTS	4
6.	FUNCTIONAL DESCRIPTIONS	5
6.1.	INTERFACE FORMAT	5
6.2.	CHANNEL SETTING.....	7
6.3.	CONTROL REGISTER SETTING.....	7
6.4.	ADC READ TIMING	8
6.5.	TIMING OF DIGITAL INPUT READING.....	9
6.6.	POWER DOWN & CHANNEL WAKE-UP.....	10
6.7.	BANDGAP REFERENCE.....	11
6.8.	INPUT CHANNEL PAD (CHANNEL 0~6)	12
6.9.	BATTERY MONITORING (CHANNEL 7 ONLY)	13
7.	ELECTRICAL CHARACTERISTICS	14
8.	APPLICATION CIRCUITS	15
9.	EXAMPLE PROGRAMS	16
9.1.	PROGRAM 1: SET CONFIGURATION OF SNAD02C	23
9.2.	PROGRAM 2: READ ADC RESULT FROM CHANNEL 1	23
9.3.	PROGRAM 3: READ DIGITAL INPUT DATA FROM CH4, CH3, CH2	23
9.4.	PROGRAM 4: POWER-DOWN SNAD02C AND HOST, AND WAKE-UP	24
9.5.	PROGRAM 5: BATTERY LOW DETECTION	24
10.	PAD DIAGRAM	26



AMENDMENT HISTORY

Version	Date	Description
Ver 1.1	February 12, 2003	First issue.
Ver 1.2	March 18, 2003	Page3: wording modification in FEATURES list Page8: modify Table-3 control register setting Page10: modify Figure-10 Page11: "enters into power down mode at the 8 th clock cycle" Page11: more descript about power-down mode setting
Ver 1.3	July 31, 2003	1. Add version code "C" of chip no. 2. Page23: MB=1 3. This spec is modified form SNAD02_V1.2

Note:

This document is used to identify the different version "B" & "C" of SNAD01, the most important is standby current and power down setting between version "B" & "C". For the detail please refer to related section.



1. GENERAL DESCRIPTION

SNAD02C is a low cost serial 10-bits ADC with 8 individual input channels. Each channel can be independently programmed to a digital or analog input mode. In the analog input mode, this single-ended channel accepts an analog input signal from 0 to V_{REF} and converts the signal into 12-bit digital codes (with 10-bit accuracy guaranteed). In the digital input mode, the channel can be treated as digital input port and the logic level appears at the channel can be acquired. SNAD02C has a synchronous 3-wires serial interface. Through this interface, the host CPU can easily control SNAD02C.

During A-to-D conversion, the typical current consumption is 500uA at 25kHz throughput-rate and +3V power supply. SNAD02C includes a power-down mode, which reduces maximum current consumption less than 1uA.

The reference voltage can be varied between 1V and $+V_{CC}$, providing a corresponding input voltage range of 0V to V_{REF} . SNAD02C also has an on-chip 1.17V bandgap reference that can be utilized for constant voltage input (especially for battery monitoring applications). The bandgap reference circuitry consumes $300\mu A @ 3V$ and can be enabled and disabled.

2. FEATURES

- ◆ Single Supply: 2.7V ~ 5.25V
- ◆ Eight Analog/Digital Input Channels.
- ◆ Internal 1.17v Bandgap Reference for Battery Monitoring. (Channel 7)
- ◆ Low Power Consumption: typical operating current: 500uA @ 3V, Standby current <1uA.
- ◆ Up to 25kHz Conversion Rate.
- ◆ 12-bits ADC with 8-bit effective number of bits
- ◆ 3-Wire Serial Interface.

3. APPLICATIONS

- ◆ Battery-Powered Systems
- ◆ Instrumentation
- ◆ Portable Data Logging
- ◆ Test Equipment
- ◆ Data Acquisition
- ◆ Process-Control Monitoring
- ◆ Digital Input Bus Extender

4. BLOCK DIAGRAM

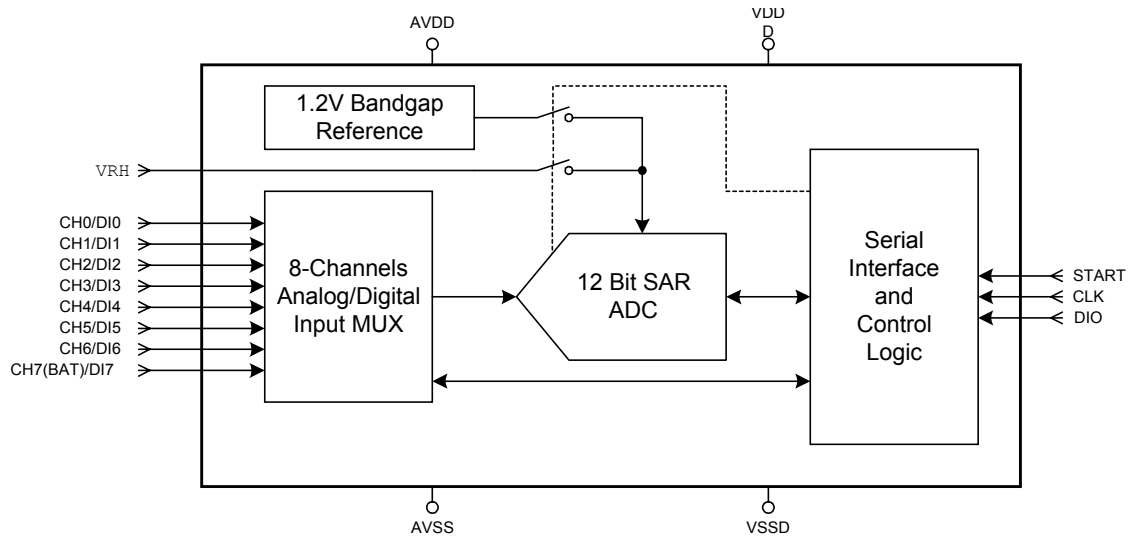

Figure-1 Block diagram of ADC

5. PIN ASSIGNMENTS

Pin Name	I/O	Description
CH[7] ~ CH[0]	I	Analog input / digital input
REF	I	Reference voltage of analog signal
VDD	I	Positive power
VSS	I	Negative power
AVDD	I	Positive power of analog circuit
AVSS	I	Negative power of analog circuit
START	I	Command initialization signal (from host controller)
CLK	I	Clock of data communication and AD conversion (from host controller)
DIO	IO	Data input and output of data communication

Table-1

6. Functional Descriptions

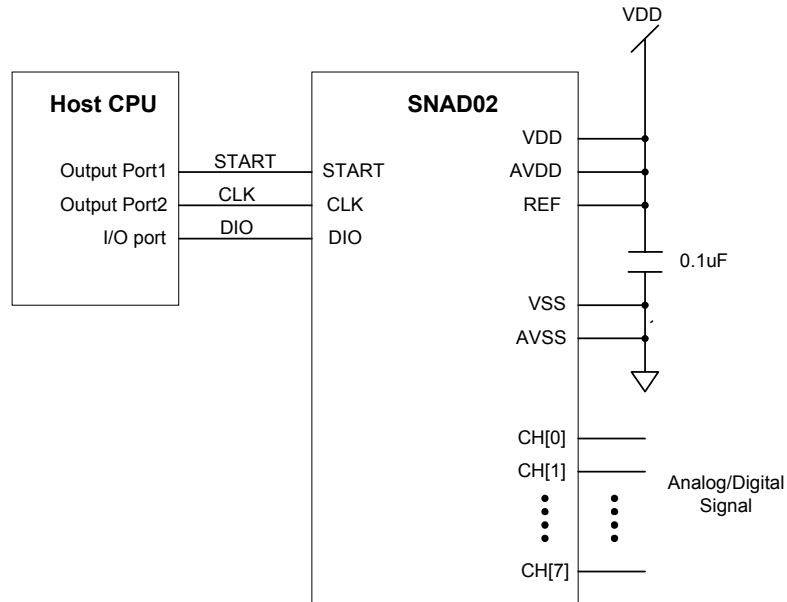

Figure-2 Interface with Host CPU

6.1. Interface Format

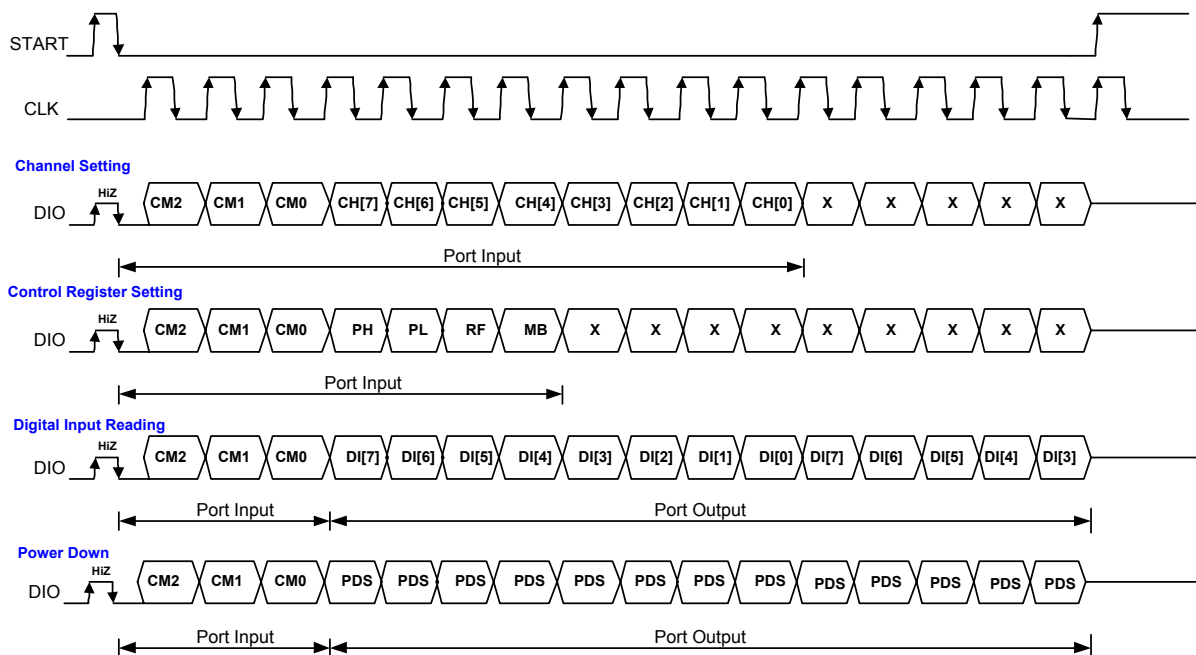

Figure-3 Timing Diagram of Whole Commands

- (1) DIO is HiZ while START is HIGH.
- (2) The interface logic begins to interpret a command at the falling edge of the START signal.
- (3) The command ID (sent by Host) is received in the first three clock cycles from DIO.
- (4) The operations include Channel setting, ADC Reading, Digital Input Reading and Power Down.
- (5) DIO becomes to HiZ while START returns to HIGH.

Command ID	Operation
000	Power Down (0)
001	Channel Attribute Setting (1:Analog, 0:Digital)
010	Channel Wakeup Function Setting (1:Enable, 0:Disable)
011	Control Register Setting
100	ADC Conversion
101	Digital Input Reading
110	Reserved
111	Power Down (1)

Table-2 Command Description Table

- a. 000/111: ADC enters into power down after receiving this command.
- b. 001: Set the attribute of each channel to be an analog or a digital input with the sequence of channel 7 to 0. (1:Analog; 0:Digital)
- c. 010: Set the wakeup function of each channel to be enabled or disabled with the sequence of channel 7 to 0. (1:Enable; 0:Disable)
- d. 011: Setting the values of control registers.
- e. 100: ADC starts to convert the analog signal of the selected channel after receiving this command.
- f. 101: ADC starts to read the digital input of every channel with the sequence of channel 7 to 0.
- g. 110: ADC enters into testing mode.

6.2. Channel Setting

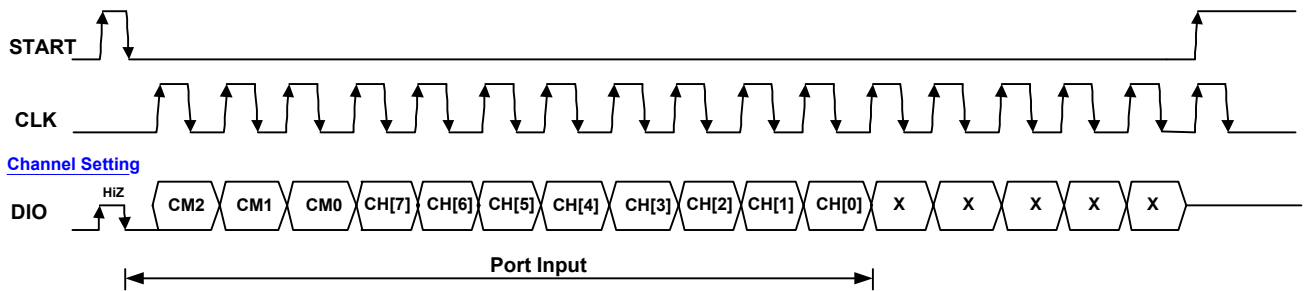

Figure-4 The timing diagram of channel attribute/wakeup setting

- (1) Command 001: channel attribute setting.
- (2) Command 010: wakeup function setting.

In attribute setting, “1” means analog and “0” means digital. In wakeup setting, “1” means enable and “0” means disable. After all of the channels are set, the DIO port remains input mode and all the following data are ignored.

6.3. Control Register Setting

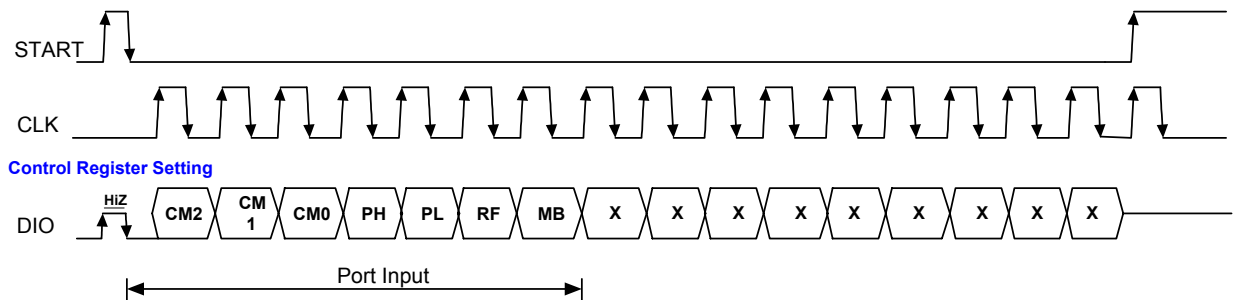

Figure-5 The timing diagram of control registers setting

- (1) Command ID: (011)
- (2) 4-bit data behind command ID are loaded into control registers with the sequence of PH, PL, RF and MB.
- (3) The function of each control registers are as Table-3.

Name	Function
PH	Set the pull-up resistor of the channel in digital input mode. 1:ON, 0:OFF.
PL	Set the pull-down resistor of the channel in digital input mode. "1": ON, "0": OFF.
RF, MB	Set the reference source (from internal bandgap or "REF" pin) RF=0, MB=1: reference voltage from "REF" pin RF=1, MB=0: reference voltage from internal bandgap

Table-3

Note:

1. The condition of both PH=1 and PL=1 is prohibited.
2. Pull-up and pull-down resistors are not activated while the corresponding channel is set as analog input mode.
3. Before into power down mode, the "RF" and "MB" register must set up "0", otherwise the standby current will more than 1uA.

6.4. ADC Read Timing

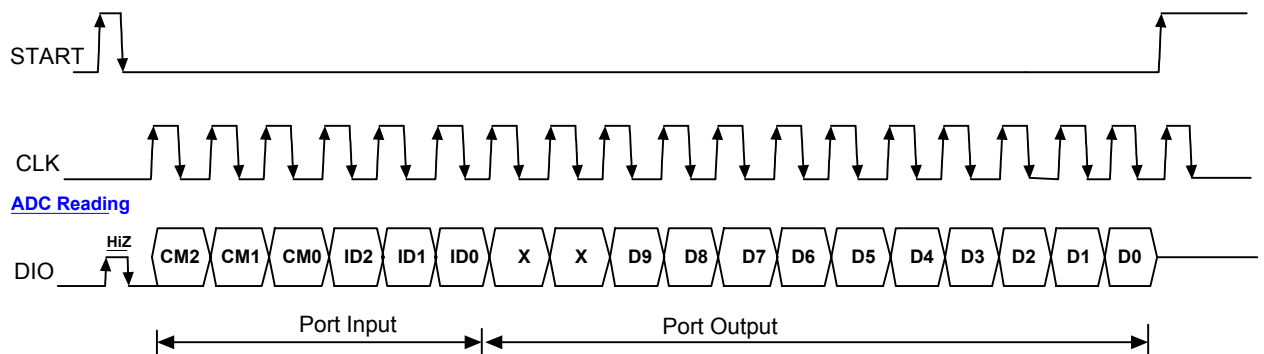

Figure-6 The timing diagram of ADC reading

- (1) Command ID: (100)
- (2) 3-bit channel number data behind command ID.
- (3) The analog signal of the selected channel is sampled to ADC. ADC refers the reference voltage and converts the sampled analog signal to digital domain by successive-approximation method.
- (4) The 10-bit output data (result of conversion) of ADC is sent to DIO port from MSB and is triggered by CLK. The maximum clock frequency is 500kHz @ 2.7v. (Maximum conversion rate=25KHz)
- (5) After the 10-bits ADC data has been sent out, if the START is kept in LOW and CLK is kept in High/Low transition, then the data with uncertain value are kept appearing on DIO. These data can just be ignored.

Channel ID[2:0]	Selected Channel
000	CH0
001	CH1
010	CH2
011	CH3
100	CH4
101	CH5
110	CH6
111	CH7

Table-4 Channel Selection Table

6.5. Timing of Digital Input Reading

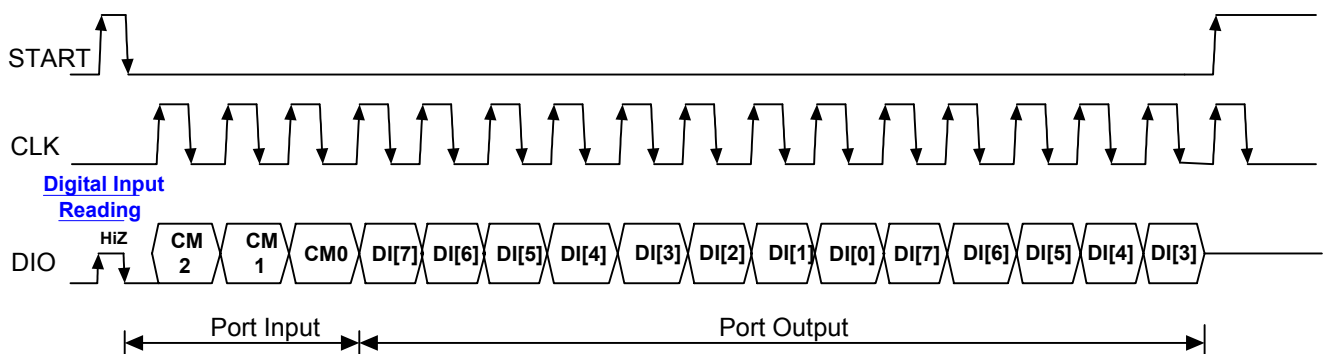

Figure-7 The timing diagram of the digital input reading

- (1) Command ID: (101).
- (2) The digital data of each channel is sent to the DIO port with the sequence of channel 7 to 0.
- (3) After all of the channels are read, if the START is kept in LOW and CLK is kept in HIGH/LOW transition, the digital data of each channel is sent to the DIO port again with the sequence of channel 7 to 0 cyclically.
- (4) Pulling START to HIGH to terminates this digital input reading.

Note: Once a channel is programmed as analog type, the corresponding data is "0" in digital input reading command.

6.6. Power Down & Channel Wake-Up

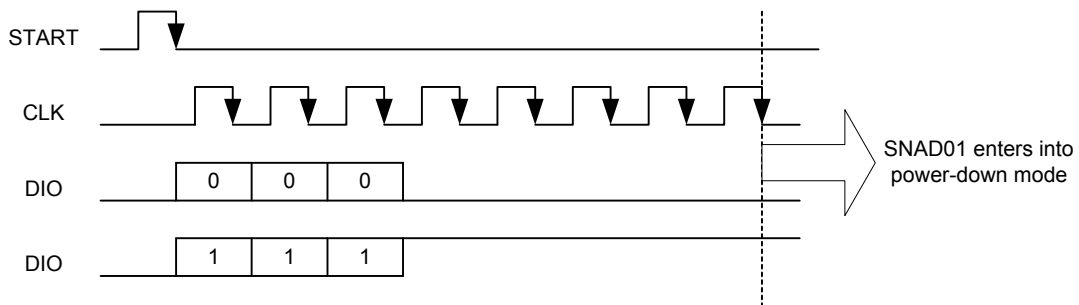

Figure-8 The timing diagram of power down command

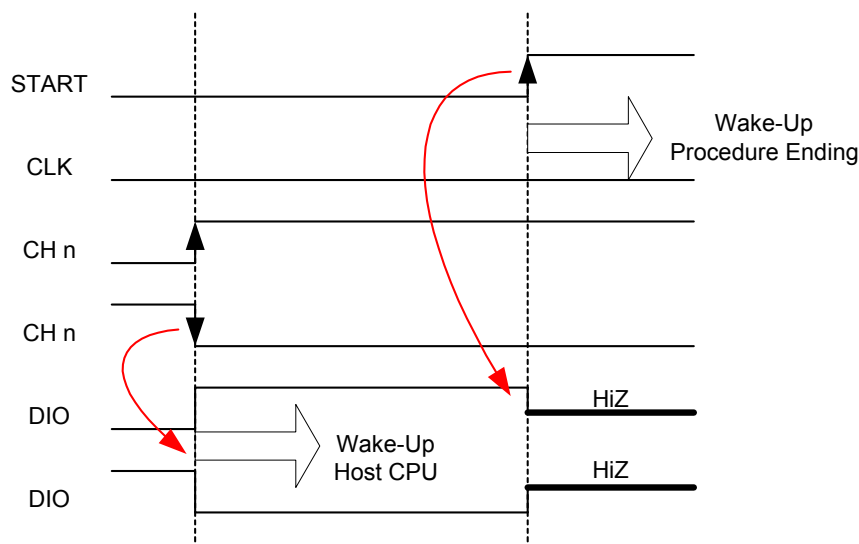

Figure-9 The timing diagram of power down command

- (1) The power down command (000/111) is sent to SNAD02C in the first three cycles, and then SNAD02C enters into power down mode at the 8th clock cycle, consuming almost no current (less than 1uA).
- (2) After SNAD02C enters power down (mode 0: command 000), SNAD02C sends “0” out to DIO until a valid logic transition appears on any wakeup-enabled digital input channel. Once the transition occurs, SNAD02C toggles DIO to “1” to inform host controller. After receiving “1” from DIO, host controller should turn START back to “1” to inform SNAD02C that the power-down stage is over. Otherwise, SNAD02C keeps sending out “1” to DIO and does not recognize any other transitions on any channels.
- (3) After SNAD02C enters power down (mode 1: command 111), SNAD02C sends “1” out to DIO until a valid logic transition appears on any wakeup-enabled digital input channel. Once the transition occurs, SNAD02C toggles DIO to “0” to inform host controller. After receiving “0” from DIO, host controller should turn START back to “1” to inform SNAD02C that the power-down stage is over. Otherwise, SNAD02C keeps sending out “1” to DIO and does not recognize any other transitions any the channels.
- (4) The CLK may stop but START ought to remain at LOW level in the whole power down mode.
- (5) The SNAD02C provides two power-down mode “POWER_DOWN 0” and “POWER_DOWN 1”, user has to select a property power-down mode that it depend on what kind I/O type for host MCU (pull-up or pull-low) before ADC enter power-down mode. Otherwise, it will generate a DC-path and the standby current also will go up.
- (6) Before into power down mode, the “RF” and “MB” register must set up “0”, otherwise the standby current will more than 1uA.

Note:

Wakeup function is only dedicated to the channel which is digital input type AND wakeup-enabled.

6.7. Bandgap reference

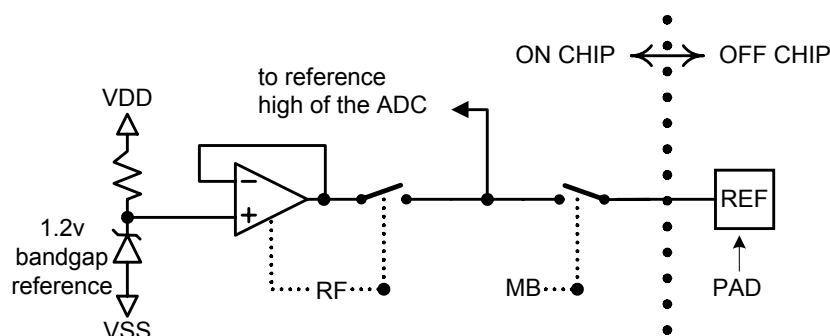

Figure-10 Circuit diagram of ADC bandgap reference selection

If the internal bandgap reference is turned ON ($RF=1$), the reference voltage “VREF” of ADC is from the internal bandgap reference circuit. This internal voltage reference circuit consumes around $300\ \mu\text{A}$, and the output voltage of bandgap reference is around 1.17V typically. If RF is turned off ($RF=0$), the MB is turned on ($MB=1$), the reference voltage is from “REF” pin. Otherwise, the reference voltage source is comes from internal bandgap if $RF=1$ & $MB=0$.

6.8. Input Channel PAD (Channel 0~6)

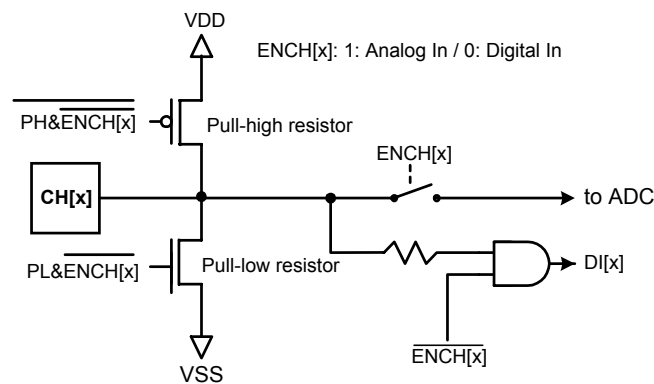

Figure-11 Circuit diagram of the Input Channel PAD

- (1) If any channel is programmed to be analog input mode, then the corresponding internal signal, $ENCH[x]=1$. As in Figure-11, pull-high and pull-low are disabled. And the path to digital input is blocked. All digital reading operation of this channel will get the result “0”.
- (2) If any channel is programmed to digital input mode, then the corresponding internal signal, $ENCH[x]=0$. As in Figure-11, the path to ADC is removed.
- (3) While in digital input mode, this input port can be configured to be floating, weak pull-up, or pull-down by setting the control register PH and PL, where $PH\&PL=1$ is forbidden. The pull-up or pull-low resistor are both around $500\text{K}\Omega@3\text{v}$.
- (4) The default status (digital/analog, pull up/down) of all the channels are un-know after power on, so initialize each channel to define a correct state should be done after power on.
- (5) Mode of each channel ($ENCH[x]$) can be set by command 001.

6.9. Battery Monitoring (Channel 7 only)

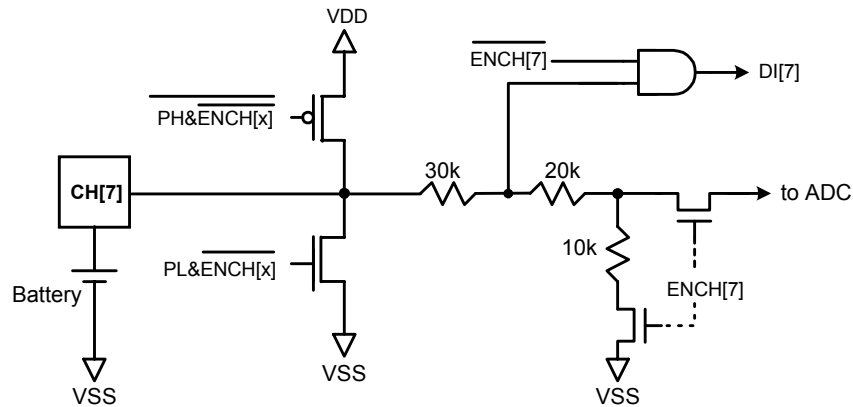

Figure-12 The circuit of the Input pad of Channel 7

- (1) While read ADC command is sent and channel 7 is selected, ADC can be used to monitor the battery voltage.
- (2) The circuit of battery voltage monitoring is shown in Figure-12 (Channel7 only)
- (3) The battery voltage is six times ADC measuring voltage. Thus, the measured result equals to $1/6 \times \text{battery voltage}$.
- (4) While channel 7 is set to the analog input mode, an input resistor ($60k\Omega$) exists from CH[7] to VSS. To save unnecessary power consumption, CH[7] should be switch to digital input type when CH[7] is not measured.

Note:

CH[7] is different from the other 7 channels. The input voltage is reduced to 1/6 before it is sent into ADC.



7. ELECTRICAL CHARACTERISTICS

Typical values apply for $V_{DD}=V_{REF}=3.0\text{ V}$, $T_{AMB}=25\text{ }^{\circ}\text{C}$ unless otherwise noted.

Symbol	Parameter	min	typ	max	Unit	Conditions
Analog-to-Digital Converter						
V_{DD}	Operating voltage	2.7	3.0	5.25	V	
I_{DD}	Operating current		400	650	μA	Excluding bandgap reference and Control Register's RF is set up 0 . $V_{DD}=3.0\text{V}$
I_{PDN}	Power Down Current		0.1		μA	$V_{DD}=3.0\text{V}$
F_{SMP}	Conversion Rate (Throughput Rate)		30 40		kHz	$V_{DD}=3.0\text{V}$ $V_{DD}=5.0\text{V}$
DNL	Differential Nonlinearity			± 0.5	LSB	
INL	Integral Nonlinearity			± 0.5	LSB	
NMC	No Missing Code	10			Bits	$V_{DD}=2.7\sim 5.25\text{V}$
SINAD	Signal to Noise and Distortion	50			dB	
ENOB	Effective Number of Bits	10			Bits	
Bandgap reference						
VBG	Bandgap reference output voltage	1.14	1.17	1.20	V	
IBG	Operating current of BGR		400		μA	
Digital Interface						
	Weak pull up/down resistance		500k		Ω	$V_{DD}=3\text{V}$
	Output drive/sink current of DIO		3		mA	$V_{OP}=V_{DD}-0.5\text{v}/V_{SS}+0.5\text{v}$

8. APPLICATION CIRCUITS

Example Circuit: SNAD02C works with Sonix 4-bit Series Controller

CH[0], CH[1], CH[2]: Analog Input

CH[6]: Digital Input

CH[7]: Battery Voltage Detect

REF=VDD+

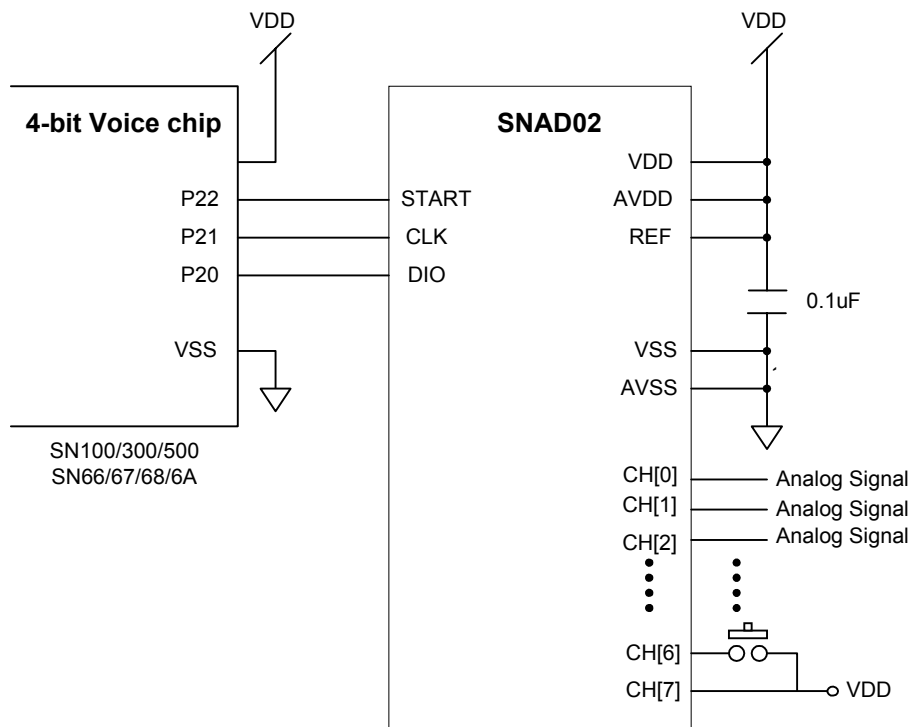

Figure-13 SNAD02C works with Sonix 4-bit Series Controller

9. EXAMPLE PROGRAMS

Host Controller: SNC500. Application circuit is identical to Figure11. P22: START. P21: CLK. P20: DIO.

◆ Macro Programs: (def.h)

```

p2State    equ    m0
port_l     equ    m1
port_h     equ    m2
ad_out_l   equ    m3
ad_out_h   equ    m4
tmp        equ    m5
tmp1       equ    m6
ad_hh      equ    m7

.....
;
@ON_START macro                ;;SET START=0
    mov a    #1011b
    and a    p2state
    mov p2state a
    mov p2    a
endm
.....
;
@OFF_START macro               ;;SET START=1
    mov a    #0100b
    or a     p2state
    mov p2state a
    mov p2    a
endm
.....
;
@CLOCK macro                   ;;SET CLK L→ H AND H→ L
    mov a    #0010b
    or a     p2state
    mov p2    a
    mov a    #1101b
    and a    p2state
    mov p2state a
    mov p2    a
endm
.....
;
@Send_0 macro                  ;;HOST SEND 0 → DIO
    mov a    #1110b
    and a    p2state
    mov p2state a
    mov p2    a
endm
.....
;
@Send_1 macro                  ;;HOST SEND 1 → DIO
    mov a    #0001b
    or a     p2state
    mov p2state a
    mov p2    a
endm
.....
;
@Send macro data;             ;;HOST SEND 1-BIT CONSTANT (#1 OR #0) → DIO
    mov tmp  data
    mov a    #1110b
    and a    p2state
    or a     tmp
    mov p2state a
    mov p2    a
endm
.....
;

```



```
@Read_DIO macro          ;;READ DIO → A.0 (1-BIT)
    mov a p2
    mov tmp #0001b
    and a tmp
    endm
*****
;;
@P20_Out_Mode macro      ;;SWITCH ALL 4-BIT OF P2 TO OUTPUT MODE
    mov a #0000b
    mov p2s a
    endm
*****
;;
@P20_In_Mode macro       ;;SWITCH P2.0 (DIO) TO INPUT MODE
    mov a #0001b
    mov p2s a
    mov a #1110b
    and a p2state
    mov p2state a
    mov p2 a
    endm

*****
;;
;; Set Analog/Digital Mode to each channel (1:Analog, 0:Digital) *
;; y7 → Ch7. y6 → Ch6. y5 → Ch5, ... *
*****
@Set_Attrib macro y7,y6,y5,y4,y3,y2,y1,y0
    @P20_Out_mode ;; SWITCH P2 TO OUTPUT MODE
    @ON_START     ;; SET START=0

    @Send_0       ;; SEND COMMAND (001)
    @Clock
    @Send_0
    @Clock
    @Send_1
    @Clock

    @Send y7      ;; SEND y7 TO y0
    @Clock
    @Send y6
    @Clock
    @Send y5
    @Clock
    @Send y4
    @Clock
    @Send y3
    @Clock
    @Send y2
    @Clock
    @Send y1
    @Clock
    @Send y0
    @Clock

    @OFF_START   ;; SET START=1
    @P20_In_mode ;; SWITCH P2.0 TO INPUT MODE
    endm
```



```
.....
;;
;; Set Wakeup function Enable/Disable (1:Enable, 0:Disable) *
;; y7 → Ch7. y6 → Ch6. y5 → Ch5, ... *
.....
@Set_Wakeup macro y7,y6,y5,y4,y3,y2,y1,y0
  @P20_Out_mode ;; SWITCH P2 TO OUTPUT MODE
  @ON_START     ;; SET START=0
  @Send_0      ;; SEND COMMAND (010)
  @Clock
  @Send_1
  @Clock
  @Send_0
  @Clock

  @Send y7     ;; SEND y7 TO y0
  @Clock
  @Send y6
  @Clock
  @Send y5
  @Clock
  @Send y4
  @Clock
  @Send y3
  @Clock
  @Send y2
  @Clock
  @Send y1
  @Clock
  @Send y0
  @Clock
  @OFF_START   ;; SET START=1
  @P20_In_mode ;; SWITCH P2.0 TO INPUT MODE
endm

.....
;;
;; Setup Control Register *
;; ph: PULL-HIGH register. pl:PULL-LOW register. *
;; rf: BANDGAP reference enable *
;; mb: Set 0 always *
.....
@Set_Control_Reg macro ph,pl,rf,mb
  @P20_Out_mode ;; SWITCH P2 TO OUTPUT MODE
  @ON_START     ;; SET START=0

  @Send_0      ;; SEND COMMAND (011)
  @Clock
  @Send_1
  @Clock
  @Send_1
  @Clock

  @Send ph     ;; SEND ph, pl, rf, mb
  @Clock
  @Send pl
  @Clock
  @Send rf
  @Clock
  @Send mb
  @Clock

  @OFF_START   ;; SET START=1
  @P20_In_mode ;; SWITCH P2.0 TO INPUT MODE
endm
```

```

..*****
;;
;; Let SNAD02C Enter Power-Down mode 0 *
..*****
;;
@Power_Down_0 macro
  @P20_Out_mode  ;; SWITCH P2 TO OUTPUT MODE
  @ON_START      ;; SET START=0
  @Send_0        ;; SEND COMMAND (000)
  @Clock
  @Send_0
  @Clock
  @Send_0
  @Clock
  @P20_In_mode  ;; SWITCH P2.0 TO INPUT MODE
  @Clock
  @Clock
  @Clock
  @Clock
  @Clock
  @Clock
  @Clock
  @Clock      ;; SNAD02C ENTERS POWER-DOWN AT THE 8-th CLOCK EDGE.
Endm
..*****
;;
;; Let SNAD02C Enter Power-Down mode 1 *
..*****
;;
@Power_Down_1 macro
  @P20_Out_mode  ;; SWITCH P2 TO OUTPUT MODE
  @ON_START      ;; SET START=0
  @Send_1        ;; SEND COMMAND (111)
  @Clock
  @Send_1
  @Clock
  @Send_1
  @Clock
  @P20_In_mode  ;; SWITCH P2.0 TO INPUT MODE
  @Clock
  @Clock
  @Clock
  @Clock
  @Clock
  @Clock
  @Clock
  @Clock      ;; SNAD02C ENTERS POWER-DOWN AT THE 8-th CLOCK EDGE.
endm
..*****
;;
;; Read ADC from Channel n (n=n2,n1,n0)
;; e.g.: Ch 5 (n2, n1, n0= #1, #0, #1)
;; 10-bit Data → (ad_hh,ad_out_h, ad_out_l)
;; ad_hh is bit9~bit8 , ad_out_h is bit7~bit4 , ad_out_l is bit3~bit0
..*****
;;
@Read_ADC macro n0, n1, n2
  @P20_Out_mode  ;; SWITCH P2 TO OUTPUT MODE
  @ON_START      ;; SET START=0

  @Send_1        ;; SEND COMMAND (100)
  @Clock
  @Send_0
  @Clock
  @Send_0
  @Clock

  @Send n2      ;; SEND CHANNEL NUMBER
  @Clock
  @Send n1
  @Clock

```



```
@Send n0
@Clock

@p20_in_mode ;; SWITCH P2.0 TO INPUT MODE
@Clock      ;; WAIT FOR 2 MORE CLOCKS
@Clock

mov ad_out_l #0
mov ad_out_h #0
mov ad_hh #0
..*****
;;
@Clock      ;; READ DIO and SAVE 1-bit DATA in ad_hh.1
mov tmp1 #0010b
@Read_DIO
caje #0 @f
mov a ad_hh
or a tmp1
mov ad_hh a
@@:
..*****
;;
@Clock      ;; READ DIO and SAVE 1-bit DATA in ad_hh.0
mov tmp1 #0001b
@Read_DIO
caje #0 @f
mov a ad_hh
or a tmp1
mov ad_hh a
@@:
..*****
;;
@Clock      ;; READ DIO and SAVE 1-bit DATA in ad_out_h.3
mov tmp1 #1000b
@Read_DIO
caje #0 @f
mov a ad_out_h
or a tmp1
mov ad_out_h a
@@:
..*****
;;
@Clock      ;; READ DIO and SAVE 1-bit DATA in ad_out_h.2
mov tmp1 #0100b
@Read_DIO
caje #0 @f
mov a ad_out_h
or a tmp1
mov ad_out_h a
@@:
..*****
;;
@Clock      ;; READ DIO and SAVE 1-bit DATA in ad_out_h.1
mov tmp1 #0010b
@Read_DIO
caje #0 @f
mov a ad_out_h
or a tmp1
mov ad_out_h a
@@:
..*****
;;
@Clock      ;; READ DIO and SAVE 1-bit DATA in ad_out_h.0
mov tmp1 #0001b
@Read_DIO
caje #0 @f
mov a ad_out_h
or a tmp1
mov ad_out_h a
```



```
@@:
..*****
13
  @Clock          ;; READ DIO and SAVE 1-bit DATA in ad_out_I.3
  mov tmp1 #1000b
  @Read_DIO
  caje #0 @f
  mov a ad_out_I
  or a tmp1
  mov ad_out_I a

@@:
..*****
13
  @Clock          ;; READ DIO and SAVE 1-bit DATA in ad_out_I.2
  mov tmp1 #0100b
  @Read_DIO
  caje #0 @f
  mov a ad_out_I
  or a tmp1
  mov ad_out_I a

@@:
..*****
13
  @Clock          ;; READ DIO and SAVE 1-bit DATA in ad_out_I.1
  mov tmp1 #0010b
  @Read_DIO
  caje #0 @f
  mov a ad_out_I
  or a tmp1
  mov ad_out_I a

@@:
..*****
13
  @Clock          ;; READ DIO and SAVE 1-bit DATA in ad_out_I.0
  mov tmp1 #0001b
  @Read_DIO
  caje #0 @f
  mov a ad_out_I
  or a tmp1
  mov ad_out_I a

@@:
..*****
13
  @Clock
  @OFF_START      ;; SET START=1
  endm

..*****
13
14 Read Digital Input: *
15 ;; 8-bit Data -> (port_h, port_l) *
..*****
16
17 @Read_Port macro
18   @P20_Out_mode  ;; SWITCH P2 TO OUTPUT MODE
19   @ON_START      ;; SET START=0
20
21   @Send_1        ;; SET COMMAND (101)
22   @Clock
23   @Send_0
24   @Clock
25   @Send_1
26   @Clock
27
28   @P20_In_mode  ;; SWITCH P2.0 TO INPUT MODE
29
30   mov port_l #0
31   mov port_h #0
..*****
13
  @Clock          ;; READ DIO and SAVE 1-bit DATA in port_h.3
  mov tmp1 #1000b
  @Read_DIO
```



```
caje #0 @f
mov a port_h
or a tmp1
mov port_h a
@@:
*****
;;
@Clock ;; READ DIO and SAVE 1-bit DATA in port_h.2
mov tmp1 #0100b
@Read_DIO
caje #0 @f
mov a port_h
or a tmp1
mov port_h a
@@:
*****
;;
@Clock ;; READ DIO and SAVE 1-bit DATA in port_h.1
mov tmp1 #0010b
@Read_DIO
caje #0 @f
mov a port_h
or a tmp1
mov port_h a
@@:
*****
;;
@Clock ;; READ DIO and SAVE 1-bit DATA in port_h.0
mov tmp1 #0001b
@Read_DIO
caje #0 @f
mov a port_h
or a tmp1
mov port_h a
@@:
*****
;;
@Clock ;; READ DIO and SAVE 1-bit DATA in port_l.3
mov tmp1 #1000b
@Read_DIO
caje #0 @f
mov a port_l
or a tmp1
mov port_l a
@@:
*****
;;
@Clock ;; READ DIO and SAVE 1-bit DATA in port_l.2
mov tmp1 #0100b
@Read_DIO
caje #0 @f
mov a port_l
or a tmp1
mov port_l a
@@:
*****
;;
@Clock ;; READ DIO and SAVE 1-bit DATA in port_l.1
mov tmp1 #0010b
@Read_DIO
caje #0 @f
mov a port_l
or a tmp1
mov port_l a
@@:
*****
;;
@Clock ;; READ DIO and SAVE 1-bit DATA in port_l.0
mov tmp1 #0001b
@Read_DIO
caje #0 @f
mov a port_l
or a tmp1
mov port_l a
```

```

@@:
.....
;;
@Clock
@OFF_START      ;; SET START=1
endm
.....
;;

```

9.1. Program 1: Set Configuration of SNAD02C

```

;; Setup Configuration of SNAD02C
;;
;; With Pull-Low, use "REF" pin connected external voltage . (PH=0, PL=1, RF=0,MB=1)
;;
;;
;;           CH7 CH6 CH5 CH4 CH3 CH2 CH1 CH0
;; Analog/Digital: B  A  A  D  D  D  A  A   :B, battery detect
;; Wakeup:       X  X  X  NO YES YES X  X
;;
SNC520
program
include def.h

START:
mov    a      #1111b
mov    p2s    a
mov    a      #0000b
mov    p2     a
mov    p2State #0

@Set_Control_Reg    #0, #1, #0, #1      ;; Set Control Registers
@Set_Attrib         #0, #1, #1, #0, #0, #0, #1, #1  ;; Set Chan Analog/Digital
@Set_Wakeup         #0, #0, #0, #0, #1, #1, #0, #0  ;; Setup Wakeup function

```

9.2. Program 2: Read ADC result from Channel 1

```

;; Inherit from program 1
;; 10-bit ADC result of channel 1 in ( ad_hh,ad_out_h, ad_out_l)
;; ad_hh is bit9~bit8, ad_out_h is bit7~bit4, ad_out_l is bit3~bit0

@Read_ADC    #0, #0, #1      ;;get ADC result from Ch1 in ( ad_hh,ad_out_h, ad_out_l)
...

```

9.3. Program 3: Read Digital Input data from Ch4, Ch3, CH2

```

;; Inherit from program 1
;; After Reading,
;; Port_h.0 = Input of Ch4
;; Port_l.3= Input of Ch3
;; Port_l.2 = Input of Ch2

@Read_Port    ;; 8-bit Data → (port_h, port_l)
...

```

9.4. Program 4: Power-down SNAD02C and Host, and Wake-up

```

;; Inherit from program 1
;; Enter Power-down Mode (0)
@Set_Control_Reg #0, #1, #0, #0      ;; Set Control Registers RF and MB is 0
@Power_Down_0                        ;; SNAD02 enters power-down Mode (0)

end                                    ;; HOST(SNC520) enter power down
...
...
TRIGGER:
@OFF_START                            ;; SET START=1
...
@Read_Port                             ;; READ Trigger condition or Debounce Procedure starting from here
...
...

```

9.5. Program 5: Battery Low Detection

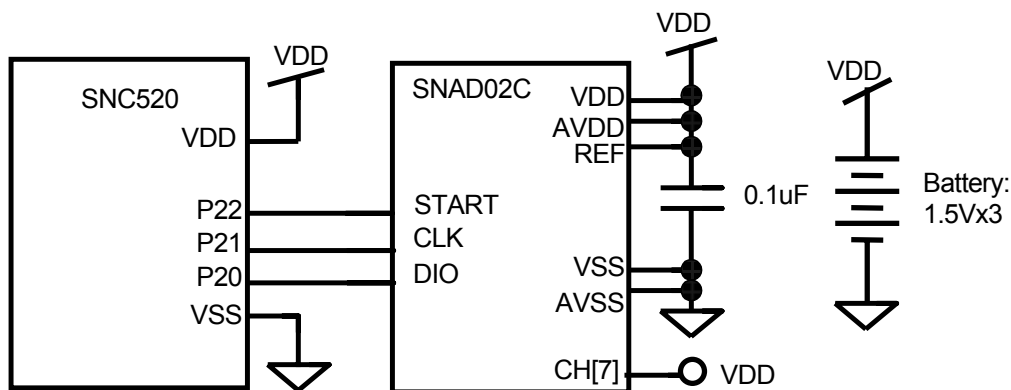

An application uses three 1.5V batteries for power supply. During operation, the power of batteries keeps consumed and the voltage of battery keeps going down. Now, voltage lower than 3.6V is treated as “Battery Low”. The ADC and band-gap reference circuit in SNAD02 can be utilized to detect “Battery Low”.

The voltage through channel 7 to ADC is reduced to $1/6 \cdot VDD$ (Figure10). Thus, when $VDD=3.6V$, the voltage into ADC is around 0.6V. And bandgap is chosen for reference voltage (approximately 1.17V within the whole operation voltage range). The value acquired from ADC is about $(0.6/1.17) \cdot 256=131$. For simplification consideration, we choose “ADC’s readout < 128” as “Battery Low” condition.



;; Inherit from program 1
;; Enter Power-down Mode (0)

CheckBattery:

@Set_Control_Reg #0, #1, #1, #0 ;; Set rf=1, turn-on bandgap
@Set_Attrib #1, #1, #1, #0, #0, #0, #1, #1 ;; Switch Ch7 to Analog

mov m15 #0

CheckAgain:

@Read_ADC #1, #1, #1 ;; Read Ch7
mov a #1000b
and a ad_out_h
caje #1000b Battery_Low_No ;; if (Value>=128) then Not Battery Low
mov a m15
inca
mov m15 a
caje #3 Battery_Low_Yes ;; if (Value<128) for 3 times, then
jmp CheckAgain ;; battery low.

Battery_Low_Yes:

mov m14 #1

Battery_Low_No:

@Set_Control_Reg #0, #1, #0, #0 ;; Set rf=0, turn-off bandgap
@Set_Attrib #0, #1, #1, #0, #0, #0, #1, #1 ;; Switch Ch7 to Digital
;; To save operating current

10. PAD DIAGRAM

NO	PAD NAME	X(um)	Y(um)	NO	PAD NAME	X(um)	Y(um)
1	CH0	-623.50	352.50	9	VSS	623.50	-417.50
2	CH1	-623.50	242.50	10	VDD	623.50	-307.50
3	CH2	-623.50	132.50	11	DIO	623.50	-197.50
4	CH3	-623.50	22.50	12	CLK	623.50	-87.50
5	CH4	-623.50	-87.50	13	START	623.50	22.50
6	CH5	-623.50	-197.50	14	AVDD	623.50	132.50
7	CH6	-623.50	-307.50	15	VSS	623.50	242.50
8	CH7	-623.50	-417.50	16	REF	623.50	352.50

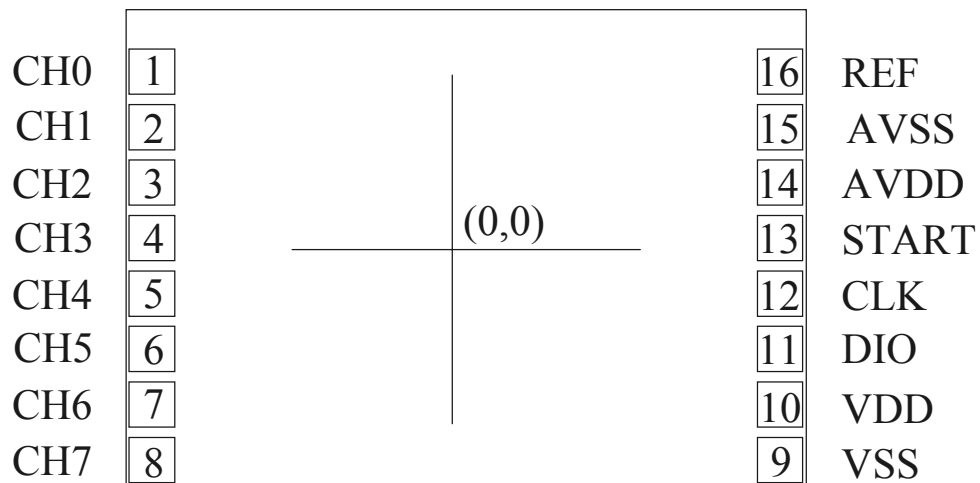

CHIP SIZE=1350 x 950um

SNAD02

Note: The substrate MUST be connected to Vss in PCB layout

DISCLAIMER

The information appearing in SONiX web pages (“this publication”) is believed to be accurate.

However, this publication could contain technical inaccuracies or typographical errors.

The reader should not assume that this publication is error-free or that it will be suitable for any particular purpose. SONiX makes no warranty, express, statutory implied or by description in this publication or other documents which are referenced by or linked to this publication. In no event shall SONiX be liable for any special, incidental, indirect or consequential damages of any kind, or any damages whatsoever, including, without limitation, those resulting from loss of use, data or profits, whether or not advised of the possibility of damage, and on any theory of liability, arising out of or in connection with the use or performance of this publication or other documents which are referenced by or linked to this publication.

This publication was developed for products offered in Taiwan. SONiX may not offer the products discussed in this document in other countries. Information is subject to change without notice. Please contact SONiX or its local representative for information on offerings available. Integrated circuits sold by SONiX are covered by the warranty and patent indemnification provisions stipulated in the terms of sale only.

The application circuits illustrated in this document are for reference purposes only. SONiX DISCLAIMS ALL WARRANTIES, INCLUDING THE WARRANTY OF MERCHANTABILITY OR FITNESS FOR ANY PURPOSE. SONiX reserves the right to halt production or alter the specifications and prices, and discontinue marketing the Products listed at any time without notice. Accordingly, the reader is cautioned to verify that the data sheets and other information in this publication are current before placing orders.

Products described herein are intended for use in normal commercial applications.

Applications involving unusual environmental or reliability requirements, e.g. military equipment or medical life support equipment, are specifically not recommended without additional processing by SONiX for such application.