



# 3V to 12V Current-Limiting Hot Swap Controllers with Autoretry, DualSpeed/BiLevel Fault Protection

## General Description

The MAX4271/MAX4272/MAX4273 comprise a complete family of integrated 3V to 12V hot swap controllers. They allow the safe insertion and removal of circuit cards into live backplanes.

The discharged filter capacitors of the circuit card provide a low impedance to the live backplane. High inrush currents from the backplane to the circuit card can burn up connectors and components, or momentarily collapse the backplane power supply leading to a system reset. This family of hot swap controllers prevents such problems by regulating the current to a preset limit when the board is plugged in, allowing the system to stabilize safely. After the startup cycle is completed, two on-chip comparators provide DualSpeed/BiLevel™ protection against short circuits, load glitches, and overcurrent conditions. In the event of a fault condition, the load is disconnected. Fault recovery is handled by unlatching (MAX4271), autoretry (MAX4272), or programmed (MAX4273) methods.

The MAX4271 family includes many integrated features that reduce component count and design time. An on-board charge pump provides the gate drive for a low-cost, external N-FET. Integrated features like startup current regulation and current glitch protection eliminate external timing resistors and capacitors. Also featured are an open-drain status output to indicate a fault condition, and an adjustable overcurrent response time.

The MAX4271 (latched fault protection) and MAX4272 (autoretry fault protection) come in the space-saving 8-pin SO package, and the MAX4273 (full function) comes in the space-saving 16-pin QSOP package. All parts are specified across the extended temperature range, and have an absolute maximum rating of 15V to provide extra protection against inductive kickback during board removal.

*DualSpeed/BiLevel is a trademark of Maxim Integrated Products.*

## Features

- ◆ Provide Safe Hot Swap for +3V to +12V Power Supplies with Minimum External Components
- ◆ Unique Current Regulation Architecture Eliminates External Timing Resistors and Capacitors and Minimizes N-FET Linear Mode Duration
- ◆ Autoretry Feature (MAX4272/MAX4273) Allows Self-Management During Fault
- ◆ DualSpeed/BiLevel Operation Protects Against Current Glitches and Short Circuits
- ◆ Power-On RESET (MAX4273)
- ◆ 15V Absolute Maximum Rating Protects Against Inductive Kickbacks During Board Removal
- ◆ Internal Charge Pump Generates Gate Drive for External N-MOSFET
- ◆ Status Output Pin Indicates Fault/Safe Condition
- ◆ Space-Saving 8-Pin SO, 16-Pin QSOP Packages

## Applications

Base Stations  
RAID  
Remote-Access Servers  
Network Routers  
Network Switches  
ISDN

*Ordering Information appears at end of data sheet.*

*Pin Configurations appear at end of data sheet.*

## Typical Operating Circuit

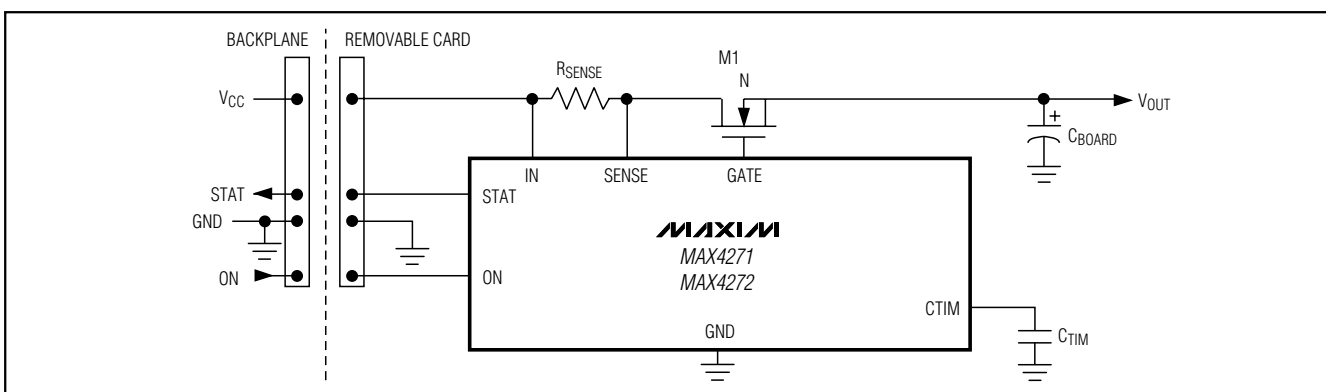

# 3V to 12V Current-Limiting Hot Swap Controllers with Autoretry, DualSpeed/BiLevel Fault Protection

## ABSOLUTE MAXIMUM RATINGS

IN to GND.....	15V	Current into INC, ON (Note 2) .....	±2mA
STAT, OUTC, LLMON, AUXVCC to GND.....	-0.3V to +14V	Current into Any Other Pin .....	±50mA
GATE to GND .....	-0.3V to (V <sub>IN</sub> + 8.5V)	Continuous Power Dissipation (T <sub>A</sub> = +70°C)	
GATE to LLMON (Note 1).....	-1V to +8.5V	8-Pin SO (derate 5.9mW/°C above +70°C).....	471mW
INC, ON to GND. (Note 2) .....	-1V to +14V	16-Pin QSOP (derate 8.3mW/°C above +70°C).....	667mW
CEXT to GND .....	-8.5V to (V <sub>IN</sub> + 0.3V)	16-Pin SO (derate 8.7mW/°C above +70°C).....	696mW
CSPD, CTON, REF to GND .....	-0.3V to the lower of (V <sub>IN</sub> + 0.3V) or +12V	Operating Temperature Range .....	-40°C to +85°C
VSEN, RTH, CTIM to GND .....	-0.3V to (V <sub>IN</sub> + 0.3V)	Storage Temperature Range .....	-65°C to +150°C
		Lead Temperature (soldering, 10s) .....	+300°C

**Note 1:** GATE can be pulled below LLMON, but current must be limited to 2mA.

**Note 2:** INC and ON can be pulled below ground. Limiting the current to 2mA ensures that these pins are never lower than about -0.8V.

Stresses beyond those listed under "Absolute Maximum Ratings" may cause permanent damage to the device. These are stress ratings only, and functional operation of the device at these or any other conditions beyond those indicated in the operational sections of the specifications is not implied. Exposure to absolute maximum rating conditions for extended periods may affect device reliability.

## ELECTRICAL CHARACTERISTICS

(V<sub>IN</sub> = +2.7V to +13.2V, T<sub>A</sub> = -40°C to +85°C, unless otherwise noted. Typical values are at V<sub>IN</sub> = +5V and T<sub>A</sub> = +25°C.) (Note 3)

PARAMETER	SYMBOL	CONDITIONS		MIN	TYP	MAX	UNITS	
<b>POWER SUPPLIES</b>								
Input Voltage Range	V <sub>IN</sub>			2.7		13.2	V	
Supply Current	I <sub>Q</sub>	ON = V <sub>IN</sub>			0.6	1	mA	
<b>CURRENT CONTROL</b>								
Slow Comparator Threshold	V <sub>SC,TH</sub>	V <sub>IN</sub> - V <sub>SENSE</sub>	T <sub>A</sub> = +25°C	45	50	55	mV	
			T <sub>A</sub> = T <sub>MIN</sub> to T <sub>MAX</sub>	43.5		56		
Slow Comparator Response Time	t <sub>CSPD</sub>	C <sub>SPD</sub> = floating		10	20	40	μs	
		C <sub>SPD</sub> = 100nF to GND		10	20	40	ms	
Fast Comparator Threshold	V <sub>FC,TH</sub>	MAX4273 only	5kΩ on RTH to V <sub>IN</sub>	T <sub>A</sub> = +25°C	45	50	55	mV
				T <sub>A</sub> = T <sub>MIN</sub> to T <sub>MAX</sub>	43.5		56	
		75kΩ on RTH to V <sub>IN</sub>	T <sub>A</sub> = +25°C	675	750	825		
			T <sub>A</sub> = T <sub>MIN</sub> to T <sub>MAX</sub>	650		840		
MAX4273 RTH = GND, MAX4271/MAX4272		180	200	220				
Fast Comparator Response Time	t <sub>FCD</sub>	10mV overdrive, from overload condition to gate discharging			350		ns	
SENSE Input Bias Current	I <sub>B,SENSE</sub>	V <sub>SENSE</sub> = V <sub>IN</sub>			0.2	10	μA	
<b>MOSFET DRIVER</b>								
Startup Period (Notes 4, 5)	t <sub>START</sub>	MAX4271/MAX4272 C <sub>TIM</sub> = 100nF		21	31	41	ms	
		MAX4273 C <sub>TON</sub> = 100nF		21	31	41		
		No capacitor			5.5		μs	
Gate Charge Current	I <sub>GATE</sub>	GATE = IN (Note 6)			100		μA	

# 3V to 12V Current-Limiting Hot Swap Controllers with Autoretry, DualSpeed/BiLevel Fault Protection

MAX4271/MAX4272/MAX4273

## ELECTRICAL CHARACTERISTICS (continued)

( $V_{IN} = +2.7V$  to  $+13.2V$ ,  $T_A = -40^{\circ}C$  to  $+85^{\circ}C$ , unless otherwise noted. Typical values are at  $V_{IN} = +5V$  and  $T_A = +25^{\circ}C$ .) (Note 3)

PARAMETER	SYMBOL	CONDITIONS	MIN	TYP	MAX	UNITS
Slow Turn-Off Time	$t_{SLOW,OFF}$	Time from trigger to $V_{GATE} < 0.1V$ (triggered by either the ON input or the slow comparator), $C_{GATE} = 1000pF$ to GND		60		$\mu s$
Fast Turn-Off Time	$t_{FAST,OFF}$	Time from current overload to $V_{GATE} < 0.1V$ (triggered by the fast comparator, during normal operation), $C_{GATE} = 1000pF$ to GND		15		$\mu s$
Maximum Gate Protection Voltage		Voltage at which internal zener clamp circuitry is triggered, measured with respect to $V_{IN}$ (MAX4271/MAX4272), measured with respect to $V_{LLMON}$ (MAX4273)		6.7	7.5	V
Minimum Gate Drive Voltage		Measured with respect to $V_{IN}$ , $I_{GATE} = 8.5\mu A$	$V_{IN} \geq 5V$	5		V
			$V_{IN} \geq 2.7V$	2.7		
Gate Discharge Current	$I_{GATE,DIS}$	During fast discharge, due to a fast comparator fault in normal operation	0.4	1	2.75	$\mu A$
		During startup (current regulation provided by fast comparator)	25	70	195	
		During normal discharge, due to a slow comparator fault in normal mode, or by ON going low	75	200	550	
LLMON Overvoltage Threshold		Startup is initiated only after $V_{LLMON}$ is less than this voltage (MAX4273)	0.1			V
GATE Overvoltage Threshold		Startup is initiated only after $V_{GATE}$ is less than this voltage	0.1		0.6	V
LLMON Impedance		Impedance to GND, after a fault (MAX4273)		1		$k\Omega$
<b>REFERENCE (MAX4273)</b>						
Output Voltage	$V_{REF}$	No load, $V_{IN} = 5V$	1.176	1.2	1.224	V
Line Regulation	$\Delta V_{REF,LINE}$	$2.7V \leq V_{IN} \leq 13.2V$ , no load		4	8	mV
Load Regulation	$\Delta V_{REF,LOAD}$	$I_{REF} = 0$ to $100\mu A$ , $V_{IN} = 5V$		1	3	mV
<b>ON AND RESET COMPARATORS</b>						
Threshold Voltage		$V_{IN} = 5V$ , rising threshold at ON or INC	0.575	0.6	0.625	V
Hysteresis	$V_{HYST}$			3		mV
Power-Supply Rejection Ratio	PSRR	$2.7V \leq V_{IN} \leq 13.2V$			$\pm 1$	mV/V
Propagation Delay	$t_{D,COMP}$	10mV overdrive, ON going positive or negative, INC going negative		10		$\mu s$
		INC going positive	100	150	200	ms

## 3V to 12V Current-Limiting Hot Swap Controllers with Autoretry, DualSpeed/BiLevel Fault Protection

### ELECTRICAL CHARACTERISTICS (continued)

( $V_{IN} = +2.7V$  to  $+13.2V$ ,  $T_A = -40^{\circ}C$  to  $+85^{\circ}C$ , unless otherwise noted. Typical values are at  $V_{IN} = +5V$  and  $T_A = +25^{\circ}C$ .) (Note 3)

PARAMETER	SYMBOL	CONDITIONS	MIN	TYP	MAX	UNITS
Input Voltage Range		Input can be driven to the absolute maximum limit without false output inversion	-0.1		13.2	V
Input Bias Current	$I_{B,COMP}$			0.001	1	$\mu A$
ON Pulse Width Low (Note 7)	$t_{RESTART}$	To unlatch a fault MAX4271, MAX4273 with $C_{TIM} = IN$	20			$\mu s$
<b>DIGITAL OUTPUTS (STAT, OUTC)</b>						
Output Leakage Current		$V_{STAT} \leq 13.2$ , $V_{OUTC} \leq 13.2$			1	$\mu A$
Output Voltage Low	$V_{OL}$	$I_{SINK} = 1mA$			0.4	V
<b>RETRY TIMING</b>						
Retry Timeout Period	$t_{RETRY}$	100nF capacitor on $C_{TIM}$ (Note 5)	0.5	1	2	s
<b>UNDERVOLTAGE LOCKOUT (UVLO)</b>						
Threshold	$V_{UVLO}$	Startup is initiated when this threshold is exceeded at IN	2.25		2.67	V
Hysteresis	$V_{UVLO,HYST}$			100		mV
Delay	$t_{D,UVLO}$	Time the input voltage must exceed undervoltage lockout before startup is initiated	100	150	200	ms

**Note 3:** All devices are 100% tested at  $T_A = +25^{\circ}C$ . All temperature limits are guaranteed by design.

**Note 4:** Startup time is the time during which the slow comparator is ignored and the fast comparator regulates the sense current. It is measured from the time ON is brought high.

**Note 5:** Inferred from test with 1nF.

**Note 6:** The current available at GATE is a function of  $V_{GATE}$  (see *Typical Operating Characteristics*).

**Note 7:** Guaranteed by design.

# 3V to 12V Current-Limiting Hot Swap Controllers with Autoretry, DualSpeed/BiLevel Fault Protection

## Typical Operating Characteristics

( $V_{IN} = 5V$ ,  $R_{SENSE} = 100m\Omega$ ,  $C_{BOARD} = 47\mu F$ ,  $T_A = +25^\circ C$ , unless otherwise noted.)

MAX4271/MAX4272/MAX4273

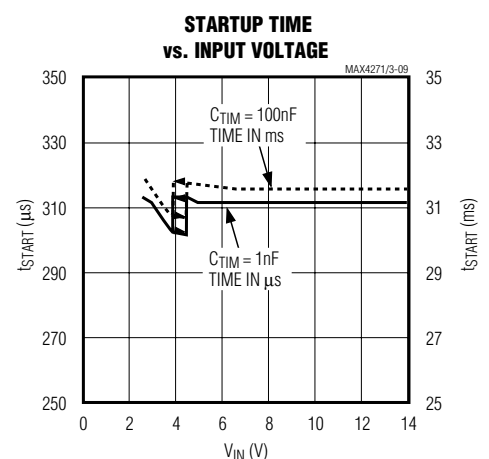
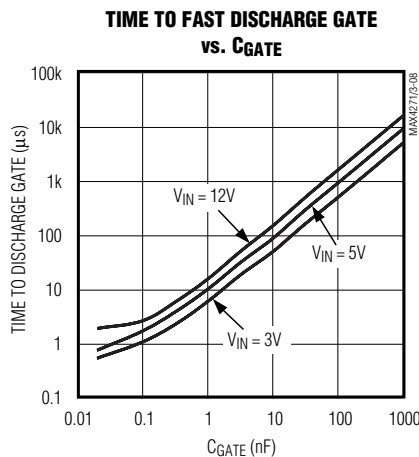
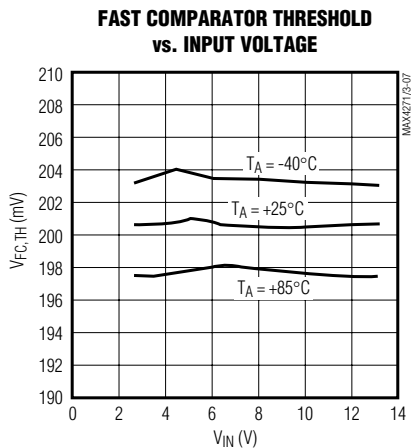
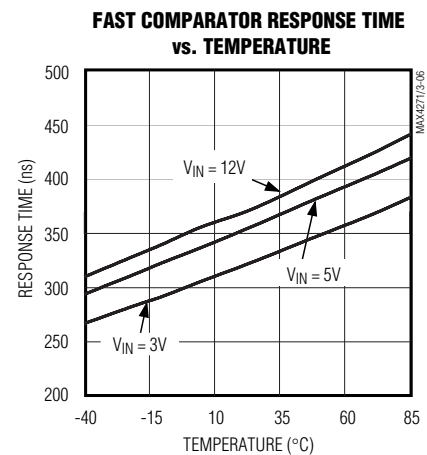
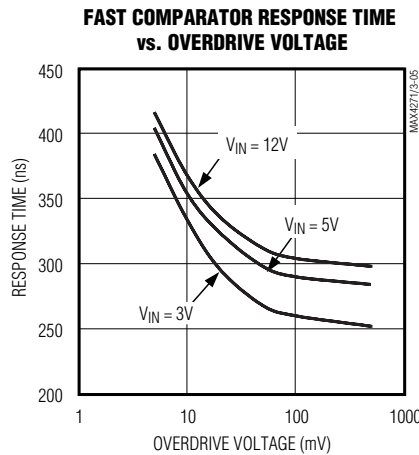
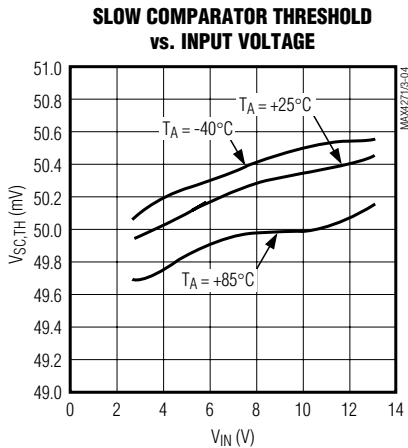
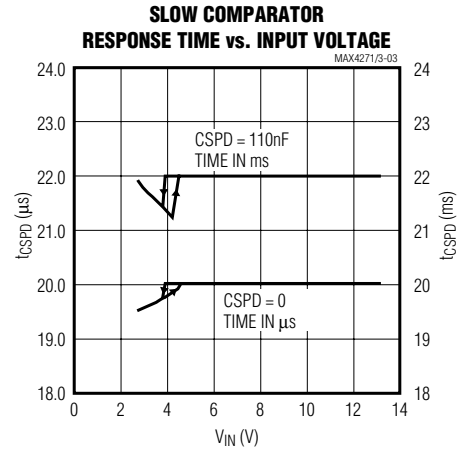
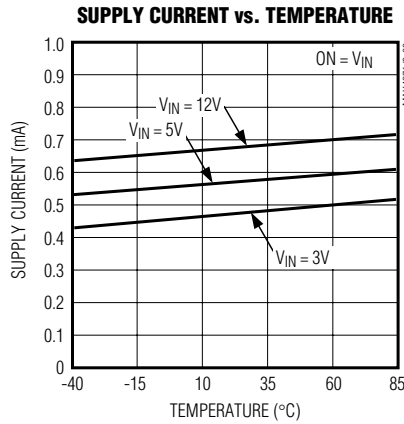
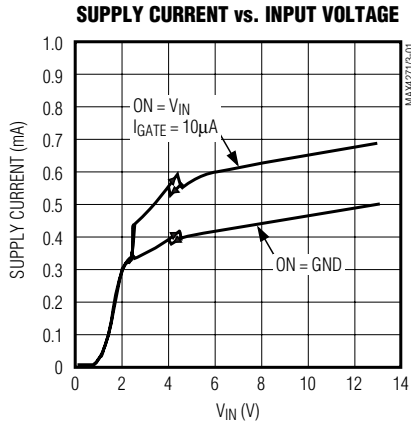

# 3V to 12V Current-Limiting Hot Swap Controllers with Autoretry, DualSpeed/BiLevel Fault Protection

## Typical Operating Characteristics (continued)

( $V_{IN} = 5V$ ,  $R_{SENSE} = 100m\Omega$ ,  $C_{BOARD} = 47\mu F$ ,  $T_A = +25^\circ C$ , unless otherwise noted.)

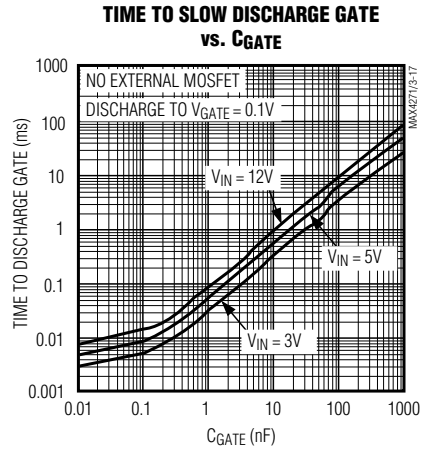
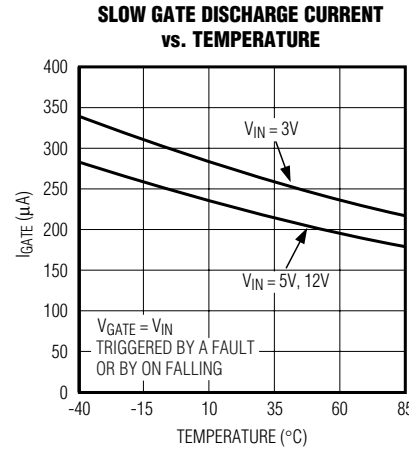
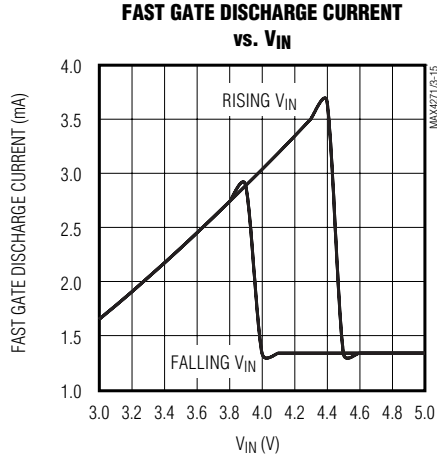
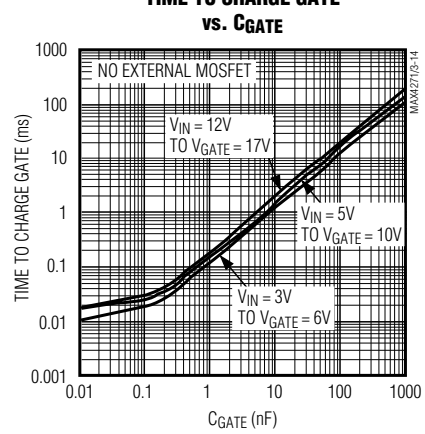
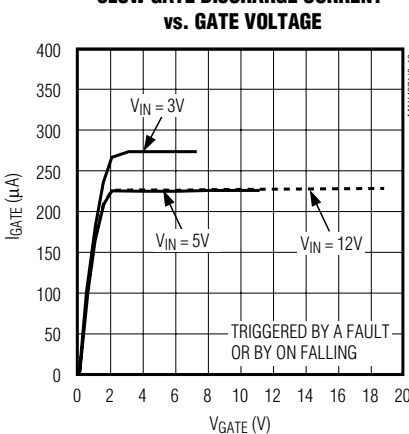
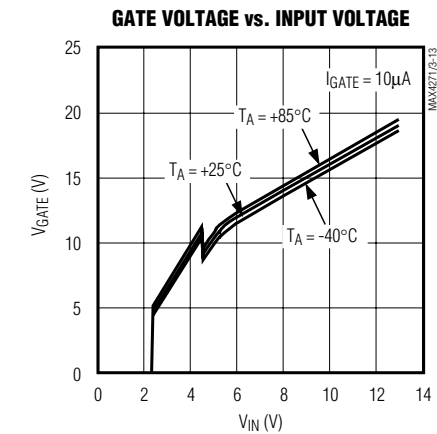
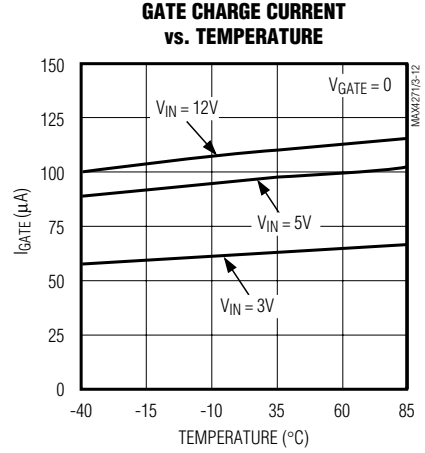
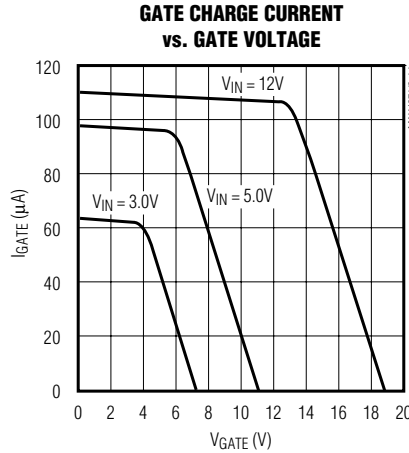
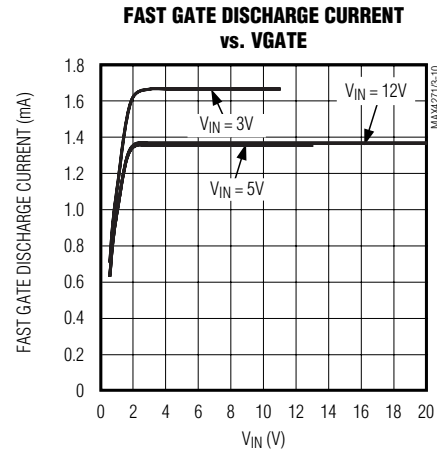

# 3V to 12V Current-Limiting Hot Swap Controllers with Autoretry, DualSpeed/BiLevel Fault Protection

## Typical Operating Characteristics (continued)

( $V_{IN} = 5V$ ,  $R_{SENSE} = 100m\Omega$ ,  $C_{BOARD} = 47\mu F$ ,  $T_A = +25^\circ C$ , unless otherwise noted.)

MAX4271/MAX4272/MAX4273

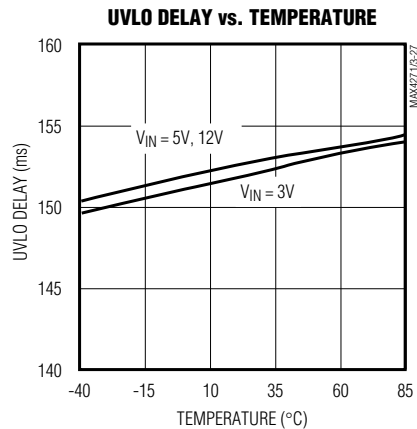
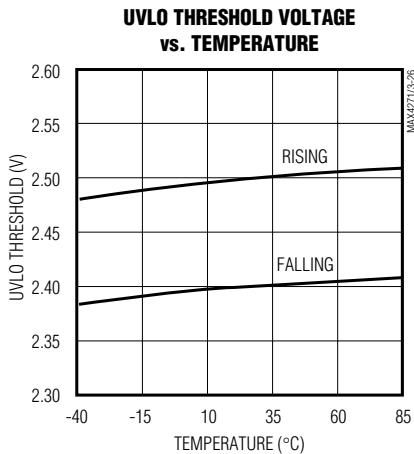
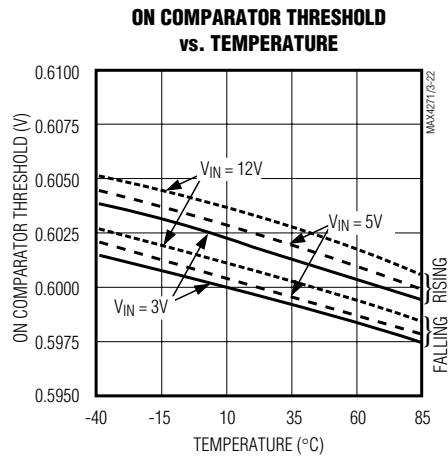
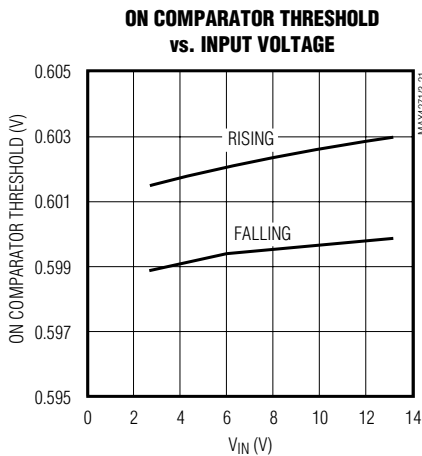
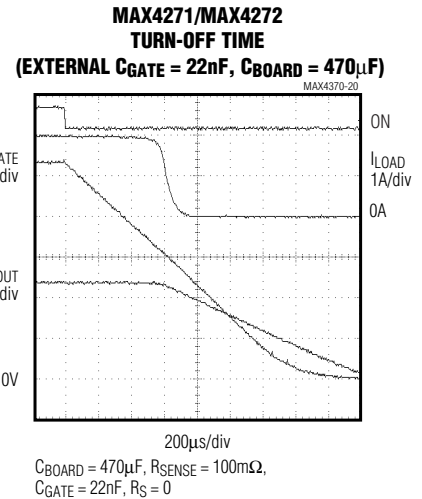
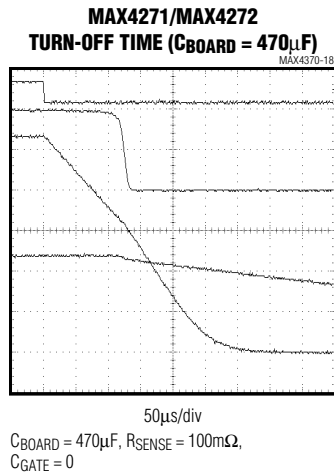
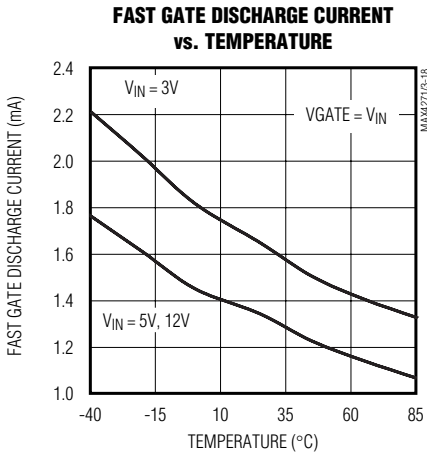

# 3V to 12V Current-Limiting Hot Swap Controllers with Autoretry, DualSpeed/BiLevel Fault Protection

## Typical Operating Characteristics (continued)

( $V_{IN} = 5V$ ,  $R_{SENSE} = 100m\Omega$ ,  $C_{BOARD} = 47\mu F$ ,  $T_A = +25^\circ C$ , unless otherwise noted.)

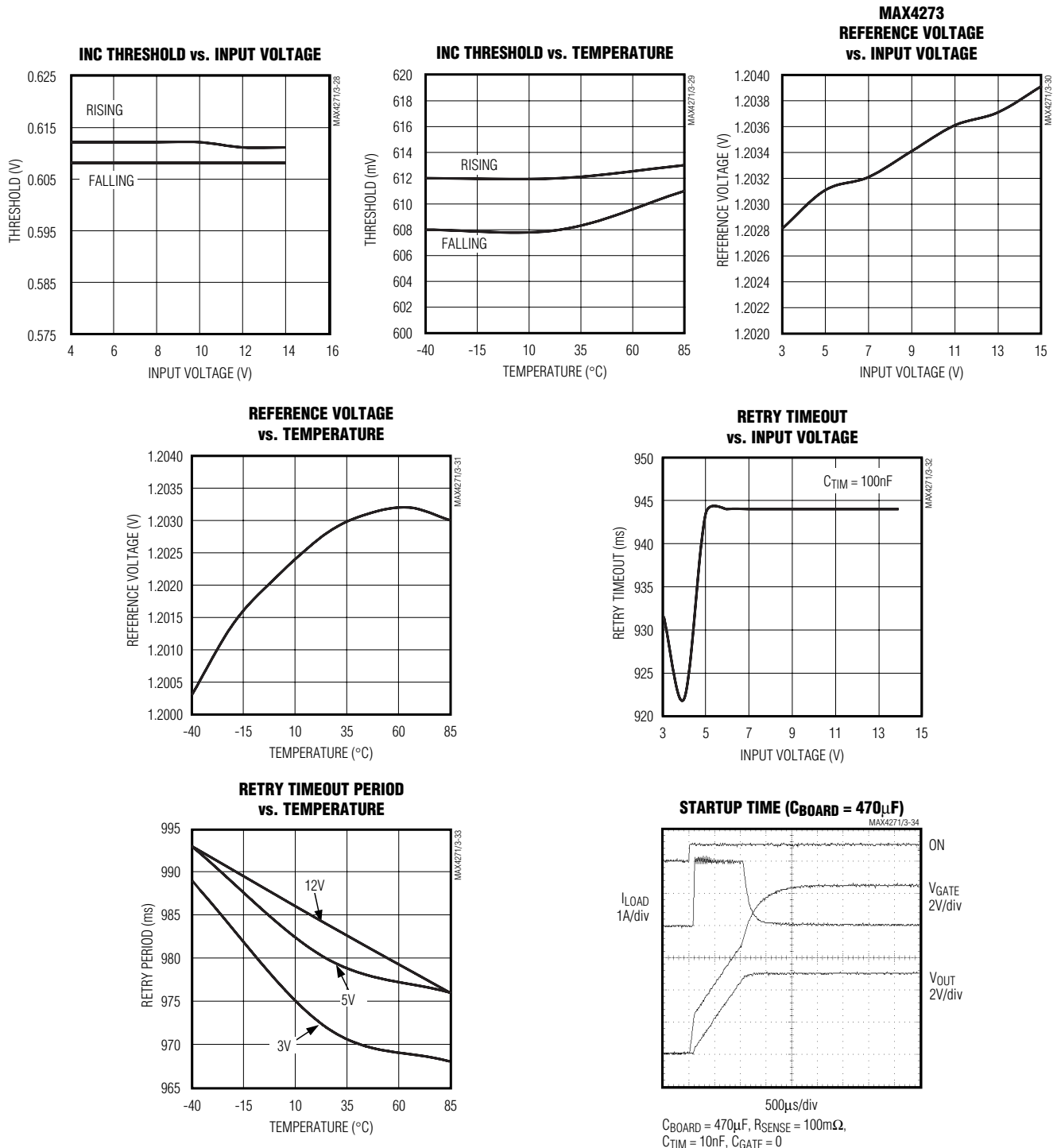



# 3V to 12V Current-Limiting Hot Swap Controllers with Autoretry, DualSpeed/BiLevel Fault Protection

## Typical Operating Characteristics (continued)

( $V_{IN} = 5V$ ,  $R_{SENSE} = 100m\Omega$ ,  $C_{BOARD} = 47\mu F$ ,  $T_A = +25^\circ C$ , unless otherwise noted.)

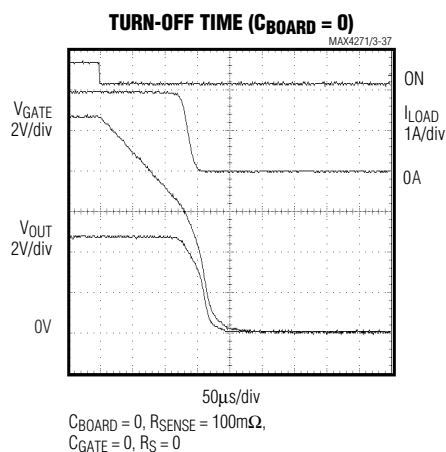
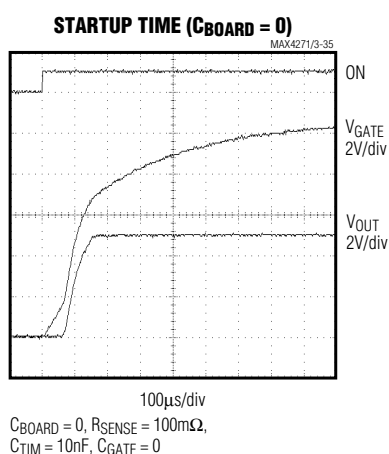

## Pin Description

PIN			FUNCTION
MAX4271 MAX4272	MAX4273	NAME	
—	1	RTH	Current-Sense Threshold Setting Input. Connect a resistor from RTH to $V_{IN}$ to set the fast comparator threshold. Bypass to $V_{IN}$ with $0.1\mu F$ . Connect RTH to $V_{IN}$ to disable both the fast comparator and current regulation at startup. Short RTH to GND for a 200mV threshold. See <i>Fast Comparator Threshold</i> section.
—	2	AUXVCC	Auxiliary Supply Input. Supply input for short-circuit switchover. To use this, connect a $1\mu F$ capacitor from AUXVCC to GND; otherwise, leave floating. See <i>Auxiliary VCC</i> section.
1	3	IN	Input Voltage. Connect to +2.7V to +13.2V supply; 15V absolute maximum voltage rating.
2	4	SENSE	Current-Sense Resistor Voltage Input. $R_{SENSE}$ is connected from IN to SENSE.
3	5	GATE	Gate Drive Output. Connect to gate of external N-channel pass transistor.
—	6	CEXT	External Gate Capacitance Connection. Connect a capacitor from CEXT to GATE to increase the gate charging time. This pin goes high impedance during a fast comparator fault for fast discharge.
—	7	LLMON	Load Line Monitor. Connect to the source of the external N-channel MOSFET. The external FET is turned on only when the load voltage is less than 100mV.
4	8	GND	Ground
—	9	CTON	Startup Timer Input. Leave floating or connect the timing capacitor from CTON to GND. See <i>Startup and Retry Timer</i> section.
5	10	CSPD	Slow Comparator Speed Setting. Leave floating or connect the timing capacitor from CSPD to GND. See <i>Slow Comparator Timer Setting</i> section.

# 3V to 12V Current-Limiting Hot Swap Controllers with Autoretry, DualSpeed/BiLevel Fault Protection

## Pin Description (continued)

PIN			FUNCTION
MAX4271 MAX4272	MAX4273	NAME	
6	11	CTIM	Startup and Retry Timers Input. Controls the startup time and the autoretry time (32x startup time) in the MAX4272, only the autoretry time in the MAX4273, and only the startup time in the MAX4271. Leave floating or connect the timing capacitor from CTIM to GND. Connect to IN for latched mode (this prevents autoretry in MAX4273). See <i>Startup and Retry Timer</i> section.
7	12	STAT	Status Output. High indicates startup completed with no fault (Table 1). STAT is an open-drain output.
8	13	ON	ON Comparator Input. Connect high for normal operation; connect low to force the MOSFET off. Comparator threshold $V_{TH,ON} = 0.6V$ allows for precise control over shutdown feature. Pulse ON low for 20 $\mu$ s min to unlatch after a fault (MAX4273 in latched mode, or MAX4271). Negative pulses are ignored during autoretry (MAX4273 in autoretry mode, or MAX4272). See <i>ON and Delayed Comparator</i> section.
—	14	REF	1.2V Reference Output. Do not bypass with a capacitor to GND.
—	15	INC	Uncommitted Comparator Input. Controls OUTC.
—	16	OUTC	Uncommitted Comparator Output. OUTC goes high 150ms after INC goes high. OUTC goes low immediately after INC goes low. OUTC is an open-drain output.

### Detailed Description

The MAX4271/MAX4272/MAX4273 are circuit breaker ICs designed for hot swap applications where a line card is inserted into a live backplane. Normally, when a line card is plugged into a live backplane, the card's discharged filter capacitors provide a low impedance that can momentarily cause the main power supply to collapse. The MAX4271/MAX4272/MAX4273 are designed to reside either in the backplane or in the removable card to provide inrush current limiting and short-circuit protection. This is achieved by using an external N-channel MOSFET, an external current-sense resistor, and two on-chip comparators. Figures 1 and 2 show the functional diagrams.

The timing and voltage levels for several critical parameters can be adjusted with external resistors, external capacitors, or by pin strapping. The timing components are optional; without them, the part is set to its nominal values, as shown in the *Electrical Characteristics*. The parameters that can be adjusted are:

- Current-limit threshold
- Slow comparator response time
- Startup timer
- Fast comparator threshold

- Autoretry timeout period (time the part is shut down after an overcurrent event)
- Shutdown configuration (latched/autoretry)
- Current overload threshold

### Startup Mode

CTIM (MAX4271/MAX4272) or CTON (MAX4273) sets the startup period (see *Startup and Retry Timers*). The startup period begins after three conditions are met:

- 1) 150ms after  $V_{IN}$  exceeds the UVLO threshold (see *Undervoltage Lockout*)

**AND**

- 2) 10 $\mu$ s after  $V_{ON} > 0.6V$

**AND**

- 3) The device is no longer in retry mode.

During startup, the slow comparator is disabled and the inrush current can be limited in two ways:

- 1) Slow ramping of the current to the load, by controlling the external MOSFET gate voltage

**OR**

- 2) Limiting the current to the load by regulating the voltage across the external current-sense resistor

# 3V to 12V Current-Limiting Hot Swap Controllers with Autoretry, DualSpeed/BiLevel Fault Protection

MAX4271/MAX4272/MAX4273

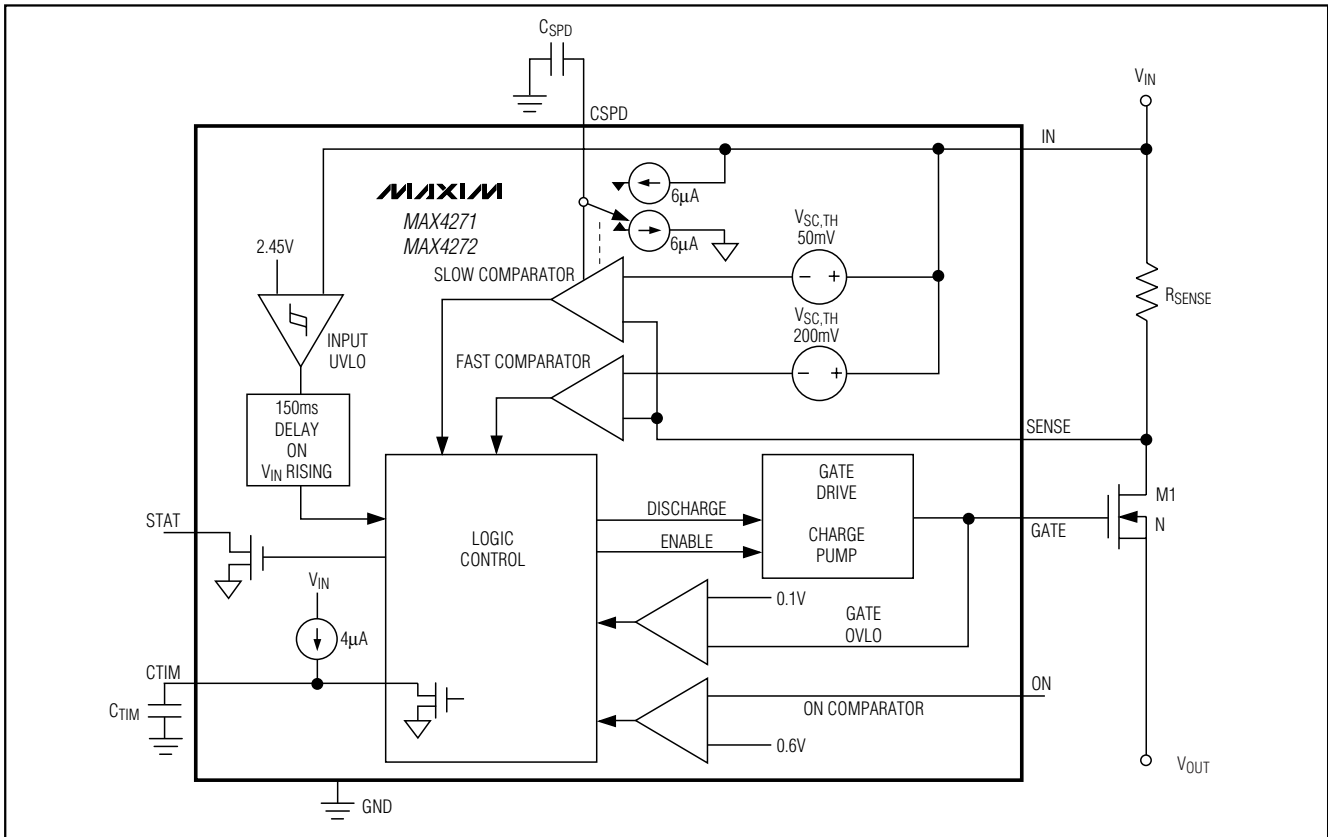

Figure 1. MAX4271/MAX4272 Functional Diagram

Unlike other circuit breaker ICs, the MAX4271/MAX4272/MAX4273 regulate the current to a preset level instead of completely turning off the external N-FET if an overcurrent condition occurs during startup.

In startup mode, the gate drive current is limited to 100µA and decreases with the increase of the gate voltage (see Gate Charge Current vs. Gate Voltage in the *Typical Operating Characteristics*). This allows the controller to slowly enhance the MOSFET. If the fast comparator detects an overcurrent, the gate voltage is momentarily discharged with a fixed 70µA current until the load current through the sense resistor ( $R_{SENSE}$ ) decreases below its threshold point. This effectively regulates the inrush current during startup. Figure 3 shows the startup waveforms. STAT goes high at the end of the startup period if no fault condition is present.

## Normal Operation (DualSpeed/BiLevel)

In normal operation (after the startup timer has expired), protection is provided by turning off the external MOSFET when a fault condition is encountered. DualSpeed/BiLevel fault protection incorporates two comparators with different thresholds and response times to monitor the current:

- 1) **Slow comparator.** This comparator has an externally set response time (from 20µs to seconds) and a fixed 50mV threshold voltage. The slow comparator ignores low-amplitude momentary current glitches. After an extended overcurrent condition, a fault is generated and the MOSFET gate is slowly discharged.
- 2) **Fast comparator.** This comparator has a fixed 350ns response time and a 200mV threshold voltage (adjustable from 50mV to 750mV in MAX4273). The fast comparator turns off the MOSFET immediately after it detects a large amplitude event such as a short circuit.

# 3V to 12V Current-Limiting Hot Swap Controllers with Autoretry, DualSpeed/BiLevel Fault Protection

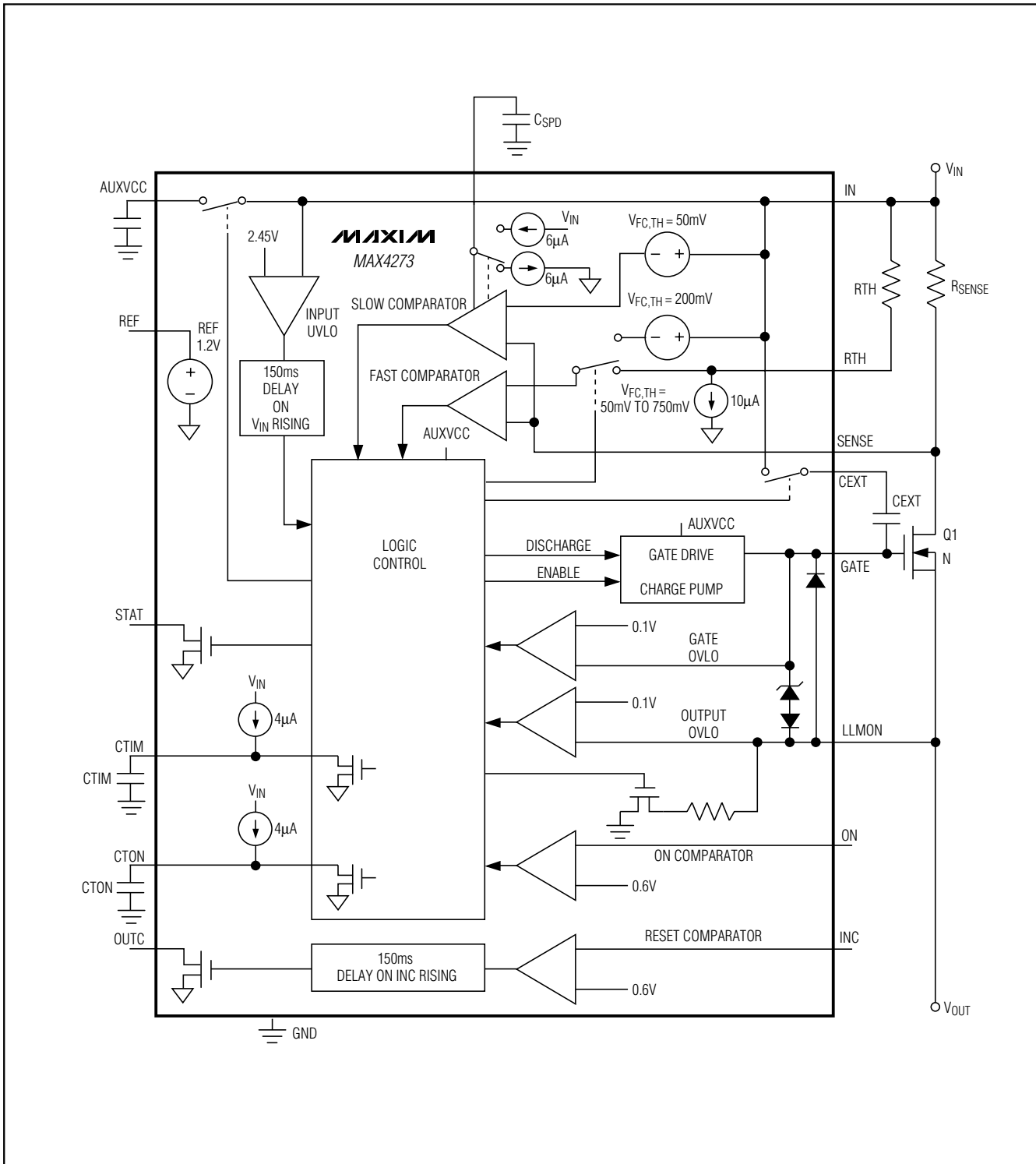

Figure 2. MAX4273 Functional Diagram

# 3V to 12V Current-Limiting Hot Swap Controllers with Autoretry, DualSpeed/BiLevel Fault Protection

In each case, when a fault is encountered, the status pin (STAT) goes low, and for the MAX4273, the device discharges the output voltage through a 1kΩ resistor from LLMON to GND. After a fault, the MAX4271 stays latched off and the MAX4272 enters retry mode, while the MAX4273 has selectable latched or retry mode. Figure 4 shows the waveforms of a fault condition.

## BiLevel Fault Protection

### Slow Comparator

The slow comparator is disabled at startup while the external MOSFET is turning on. This allows the part to ignore the higher-than-normal inrush current charging the board capacitors when a card is first plugged in.

If the slow comparator detects an overload condition while in normal operation (after startup is completed), it turns off the external MOSFET by discharging the gate capacitance with a 200μA current. The slow comparator threshold is set at 50mV and has a default delay of 20μs (CSPD floating), allowing it to ignore power-supply glitches and noise. The response time can be lengthened with an external capacitor at CSPD (Figure 10).

If the overcurrent condition is not continuous, then the duration above the threshold minus the duration below must be greater than 20μs (or the external programmed value) for the device to trip. When the current is above the threshold, CSPD is charged with a 6μA current source. A fault is detected when CSPD is charged to

the trip point of 1.2V. Therefore, a pulsing current with a duty cycle of 50% or greater (i.e., the current is above the threshold level > 50% of the time) is considered a fault condition even if it is never higher than the threshold for a longer period than the slow comparator's set response time.

The discharge rate depends on the N-FET gate capacitance and the external capacitance at GATE. In the MAX4273, CEXT remains connected and capacitance to this point has to be discharged by the same current. This increases the discharge time. Once the fault condition is detected, the STAT pin goes low and the device goes into retry or latched mode.

### Fast Comparator

The fast comparator behaves differently according to the operating mode.

During startup, the fast comparator is part of a simple current regulator. When the sensed current is above the fast comparator threshold, the gate is discharged with a 70μA current source. When the sensed current drops below the threshold, the charge pump turns on again. The sensed current will rise and fall near the threshold due to the fast comparator and charge-pump propagation delay. The gate voltage will be roughly saw-tooth shaped, and the load current will present a 20% ripple. The ripple can be reduced by adding a capacitor from GATE to GND.

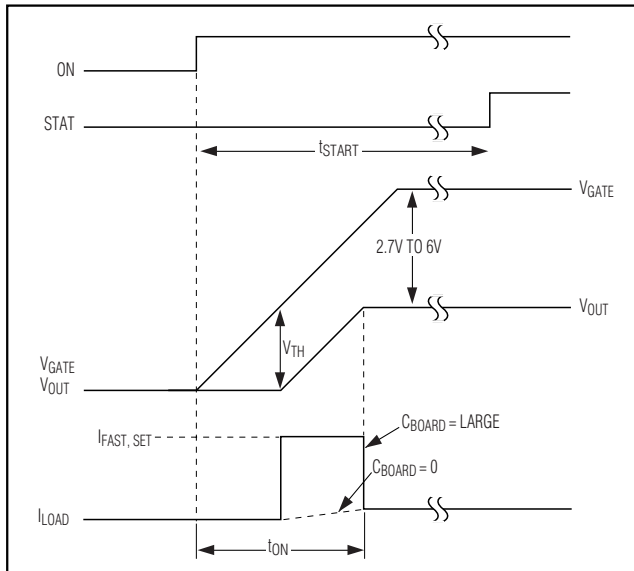

Figure 3. Startup Waveforms

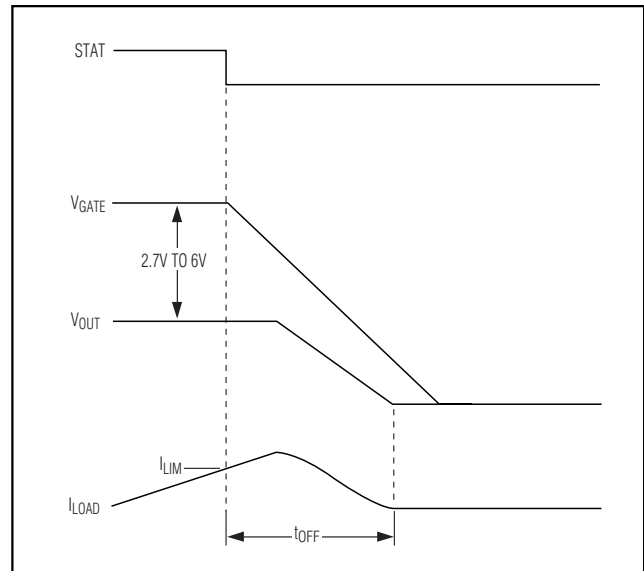

Figure 4. Response to a Fault Condition

## 3V to 12V Current-Limiting Hot Swap Controllers with Autoretry, DualSpeed/BiLevel Fault Protection

If the sensed current is still high after the startup timer expires, the MOSFET gate is discharged completely as described below.

In normal operation (after startup), the fast comparator is used as an emergency off switch. If the load current reaches the fast comparator threshold, the device quickly forces the MOSFET off completely. This could happen in the event of a serious current overload or a dead short. The fast comparator has a 350ns response time and discharges GATE with a 1mA current. Given a 1000pF gate capacitance and 12V gate voltage, the MOSFET will be off in about 12 $\mu$ s. Any additional capacitance connected between GATE and GND to slow down the startup time also increases the turn-off time.

In the MAX4273, CEXT goes high impedance during the fast discharge. This reduces the effective capacitance on GATE if a capacitor is used between GATE and CEXT, and allows the MOSFET to quickly turn off. In turn, this allows adjustment of the MOSFET charging time without affecting the fast discharge rate, although it does affect the slow discharge rate.

The MAX4271/MAX4272 fast comparator threshold is set to four times the slow comparator threshold (i.e., 200mV). The MAX4273 fast comparator threshold is set to 200mV by connecting RTH to GND, is disabled by connecting RTH to IN, or is adjustable by an external resistor connected to IN (see *Fast Comparator Threshold (RTH)*).

### Latched/Autoretry

The MAX4271 MOSFET driver stays latched off after a fault condition until it is reset by a negative-going pulse on the ON pin. The MAX4272 is periodically turned on after a fault condition with a timeout duration set by an external timing capacitor on CTIM. The MAX4273 has a selectable latched mode or retry mode. Connect CTIM to IN to set the device in latched mode, or use an external capacitor at CTIM to set the retry timeout.

Pulse ON low for 20 $\mu$ s (min) to restart after a fault (MAX4271/MAX4273 in latched mode). Negative pulses are ignored during autoretry (MAX4273 in autoretry mode, or MAX4272).

The capacitor on CTIM affects the MAX4272's retry timeout period (time the part is shut down after an overcurrent event) and the startup time (see the *Electrical Characteristics*). The retry timeout period is fixed at 32 times the startup time in order to minimize power dissipation in the external MOSFET in case of a short-circuit condition (see *MOSFET Thermal Considerations*). This is not an issue for parts latched off during a fault condition since they stay off until commanded on. The MAX4273 configured in retry mode has a separate startup timer capacitor (CTON) and retry timeout capacitor (CTIM). This allows the user to change the ratio between startup time and retry timeout period.

### Status Output

The status output is an open-drain output that goes low under the following conditions:

- During the UVLO delay period
- In startup
- Forced off (ON <0.6V)
- In an overcurrent condition
- In the retry timeout period (or latched off, for the latched parts)

STAT is high only if the part is in normal mode and no faults are present (Table 1). Figure 5 shows the status (STAT) output timing diagram.

### Over/Undervoltage Lockouts

The UVLO prevents the MAX4271/MAX4272/MAX4273 from turning on the external MOSFET until  $V_{IN}$  exceeds the lockout threshold (2.25V min) for 150ms. The UVLO protects the external MOSFET from insufficient gate drive voltage. The 150ms timeout ensures that the board is fully plugged into the backplane and that  $V_{IN}$

**Table 1. Status Output Truth Table**

IN UVLO DELAY PERIOD	PART IN STARTUP	ON PIN	OVERCURRENT CONDITION	PART IN RETRY-TIMEOUT PERIOD (OR LATCHED OFF DUE TO OVERCURRENT CONDITION)	STAT PIN (STATUS)
Yes	X	X	X	X	Low
X	Yes	X	X	X	Low
X	X	Low	X	X	Low
X	X	X	Yes	X	Low
X	X	X	X	Yes	Low
No	No	High	No	No	High

# 3V to 12V Current-Limiting Hot Swap Controllers with Autoretry, DualSpeed/BiLevel Fault Protection

MAX4271/MAX4272/MAX4273

is stable. Any input voltage transient at IN below the UVLO threshold will reset the device and initiate a start-up sequence.

These devices also have an overvoltage lockout (OVLO) feature that prevents the device from restarting after a fault condition if the discharge has not been completed.  $V_{GATE}$  has to be discharged to below 0.1V. Additionally, the MAX4273 LLMON pin discharges the load line with a 1k $\Omega$  pulldown and prevents startup until the load voltage is below 0.1V.

Since the MAX4271/MAX4272 do not monitor the output voltage, a startup sequence can be initiated while the board capacitance is still charged.

A large board capacitance or a short startup period may prevent the MAX4272 from charging completely in one startup period. The MAX4272 responds to these conditions by charging the capacitor with bursts defined by a  $t_{ON}$  duty cycle and a period of  $t_{ON} + t_{RETRY}$ . The charging will be complete after several retries unless the resistive load or current load excessively discharges the board capacitance during the retry timeout. This feature applies to the MAX4273 if LLMON is left floating or is connected to GND. To prevent multiple charging bursts, ensure that the  $t_{ON}$  timer exceeds the minimum time required to complete the charge of the board capacitance (see *Component Selection*).

### Gate Overvoltage Protection

New-generation MOSFETs have an absolute maximum rating of  $\pm 8V$  for the gate-to-source voltage ( $V_{GS}$ ). To protect these MOSFETs, the MAX4271/MAX4272 limit the gate-to-drain voltage (the MAX4273 limits the gate-to-source voltage) to +7.5V with an internal zener diode. No protection is provided for negative  $V_{GS}$  (MAX4271/MAX4272). If GATE can be discharged to ground faster than the output voltage, an external small-signal protection diode (D1) can be used, as shown in Figure 6. The MAX4273 has the protection diode internal.

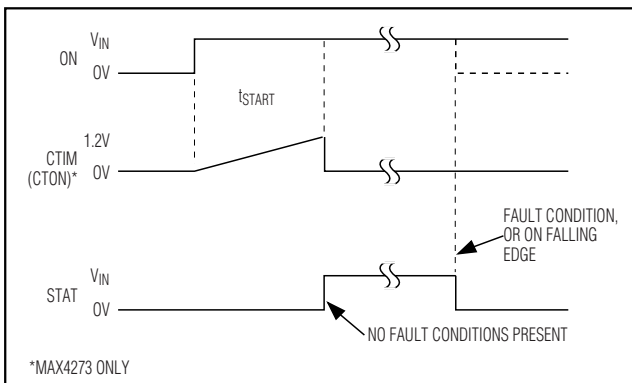

Figure 5. Status (STAT) Output Timing Diagram

## Applications Information

### Component Selection

#### N-Channel MOSFET

Select the external N-channel MOSFET according to the application's current level. Table 2 lists some recommended components. The MOSFET's On-Resistance ( $R_{DS(ON)}$ ) should be chosen low enough to have a minimum voltage drop at full load to limit the MOSFET power dissipation. High  $R_{DS(ON)}$  can cause output ripple if the board has pulsing loads or triggers an external undervoltage reset monitor at full load. Determine the device power-rating requirement to accommodate a short circuit on the board at startup

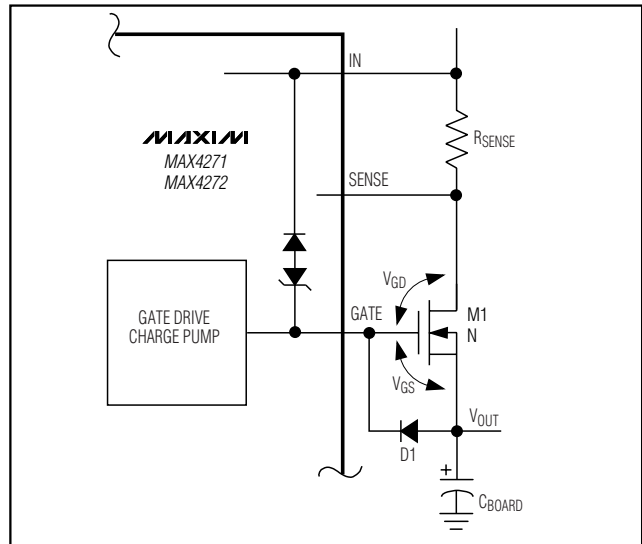

Figure 6. External Gate-Source Protection

Table 2. Recommended N-Channel MOSFETs

PART NUMBER	MANUFACTURER	DESCRIPTION
IRF7413	International Rectifier	11m $\Omega$ , 8 SO, 30V
IRF7401		22m $\Omega$ , 8 SO, 20V
IRL3502S		6m $\Omega$ , D2PAK, 20V
MMSF3300	Motorola	20m $\Omega$ , 8 SO, 30V
MMSF5N02H		30m $\Omega$ , 8 SO, 20V
MTB60N05H		14m $\Omega$ , D2PAK, 50V
FDS6670A	Fairchild	10m $\Omega$ , 8 SO, 30V
NDS8426A		13.5m $\Omega$ , 8 SO, 20V
FDB8030L		4.5m $\Omega$ , D2PAK, 30V



# 3V to 12V Current-Limiting Hot Swap Controllers with Autoretry, DualSpeed/BiLevel Fault Protection

with the device configured in automatic retry mode (see *Thermal Considerations*).

Using the MAX4271/MAX4273 in latched mode allows the consideration of MOSFETs with higher  $R_{DS(ON)}$  and lower power ratings. A MOSFET can typically withstand single-shot pulses with higher dissipation than the specified package rating. Low MOSFET gate capacitance is not necessary since the inrush current limiting is achieved by limiting the gate  $dv/dt$ . Table 3 lists some recommended manufacturers and components.

### Sense Resistor

The slow comparator threshold voltage is set at 50mV. Select a sense resistor that causes a 50mV voltage drop at a current level above the maximum normal operating current; typically, set the overload current at 1.2 to 1.5 times the nominal load current. The fast comparator threshold is typically set at 200mV. This will set the fault current limit at four times the overload current limit. The MAX4273 fast comparator threshold can be set between 50mV and 750mV; see Table 4 for a detailed listing.

Choose the sense resistor power rating according to the device configuration. If no retry mode is selected,  $P_{RSENSE} = (I_{OVERLOAD})^2 \times R_{SENSE}$ ; if retry is selected, then  $P_{RSENSE} = (I_{FAULT})^2 \times R_{SENSE} \times (t_{ON}/t_{RETRY})$ .

### Fast Comparator Threshold (RTH) (MAX4273)

The fast comparator threshold is determined by the external resistor connected at RTH. To select threshold voltages between 50mV and 750mV, use resistor values between 5k $\Omega$  and 75k $\Omega$  according to Figure 7.

Resistor values between 200 $\Omega$  and 5k $\Omega$  are not recommended. Setting the threshold voltage of the fast comparator below 50mV will effectively override the slow comparator operation. The MAX4273 fast comparator can be disabled by shorting the RTH pin to  $V_{IN}$  ( $V_{IN} - 25mV$  or less). Ground RTH to set the threshold to 200mV internally.

### Startup and Retry Timers (CTIM, CTON)

The startup ( $t_{START}$ ) and retry ( $t_{RETRY}$ ) timers are determined by the capacitors connected at CTIM and CTON. The capacitor connected to CTIM has two functions for the three devices as follows:

DEVICE	CTIM FUNCTION
MAX4271	Startup time
MAX4272	Startup time and sets retry timer
MAX4273	Sets retry timer

**Table 3. Component Manufacturers**

COMPONENT	MANUFACTURER	PHONE	WEB
Sense Resistors	Dale-Vishay	402-564-3131	www.vishay.com
	IRC	704-264-8861	www.irctt.com
MOSFETS	Fairchild	888-522-5372	www.fairchildsemi.com
	International Rectifier	310-322-3331	www.irf.com
	Motorola	602-244-3576	www.mot-sps.com/ppd/

**Table 4. Current Levels vs. RSENSE**

$R_{SENSE}$ (m $\Omega$ )	PART NUMBER	OVERLOAD THRESHOLD SET BY SLOW COMPARATOR (A)	FAULT CURRENT THRESHOLD SET BY FAST COMPARATOR (A)
10	MAX4271/MAX4272	5	20
	MAX4273	5	5 to 75
50	MAX4271/MAX4272	1	4
	MAX4273	1	1 to 15
100	MAX4271/MAX4272	0.5	2
	MAX4273	0.5	0.5 to 7.5



# 3V to 12V Current-Limiting Hot Swap Controllers with Autoretry, DualSpeed/BiLevel Fault Protection

CTON determines the maximum time allowed to complete turn-on for the MAX4273. The default values for turn-on time ( $t_{ON}$ ) and  $t_{RETRY}$  are chosen by leaving these pins floating; they are 10 $\mu$ s and 320 $\mu$ s, respectively. These are also the minimum values (not controlled and dependent on stray capacitance). Longer timings are determined by the size of the capacitor according to Figure 8, and can be determined in Table 5, which lists the startup and retry timing parameters

Set the  $t_{ON}$  timer long enough to allow for the MOSFET to be enhanced and the load capacitor to be charged completely.

There are two ways of completing the startup sequence. **Case A** describes a startup sequence that does not use the current-limiting feature and slowly turns on the MOSFET by limiting the gate dv/dt. **Case B** uses the current-limiting feature and turns on the MOSFET as fast as possible while still preventing a high in-rush current.

## Case A. Startup Without Current Regulation

There are three ways to turn on the MOSFET without reaching the fast comparator current limit:

- 1) If the board capacitance is small, the inrush current is low.
- 2) If the gate capacitance is high, the MOSFET turns on slowly.
- 3) The fast comparator can be disabled (MAX4273 only).

In all three cases,  $t_{ON}$  is determined only by the charge required to enhance the MOSFET. Effectively, the small gate-charging current limits the output voltage  $dv/dt$ . This time can be extended by connecting an external capacitor between GATE and GND (MAX4271/MAX4272) (Figure 9) or between GATE and CEXT (MAX4273). The turn-on time is dominated by the external gate capacitance if this value is considerably higher than the MOSFET gate capacitance. Table 6 shows the timing required to enhance the recommended MOSFET with or without the external capacitor; Figure 3 shows the related waveforms and timing diagrams. (See Time to Charge Gate vs.  $C_{GATE}$  and Startup Time with  $C_{BOARD} = 0$  in the *Typical Operating Characteristics*.) Remember that a high gate capacitance also increases the turn-off time ( $t_{OFF}$ ), except in the case of a MAX4273 fast fault.

If an external gate capacitor is not used,  $R_S$  is not necessary.  $R_S$  prevents MOSFET source oscillations that can occur when  $C_{GATE}$  is high while  $C_{BOARD}$  is low.

Electrical characteristics as specified by the manufacturer's data sheet are:

FDS6670A:  $C_{ISS} = 3200\text{pF}$ ,  $Q_T(\text{MAX}) = 50\text{nC}$ ,  $R_{DS(\text{ON})} = 8.2\text{m}\Omega$

IRF7401:  $C_{ISS} = 1600\text{pF}$ ,  $Q_T(\text{MAX}) = 48\text{nC}$ ,  $R_{DS(\text{ON})} = 22\text{m}\Omega$

MMSF5N03HD:  $C_{ISS} = 1200\text{pF}$ ,  $Q_T(\text{MAX}) = 21\text{nC}$ ,  $R_{DS(\text{ON})} = 40\text{m}\Omega$

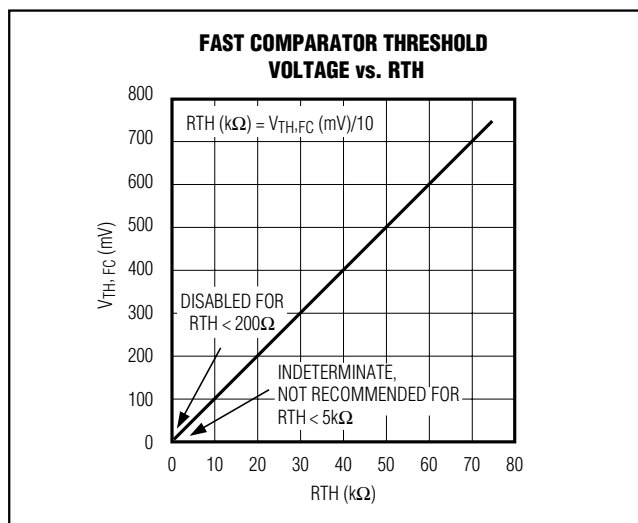

Figure 7. Fast Comparator Threshold vs. RTH

Table 5. Startup and Retry Timing Parameters

PART	$t_{ON}$		$t_{RETRY}$	
	DEFAULT ( $\mu$ s)	EXTERNALLY SET	DEFAULT ( $\mu$ s)	EXTERNALLY SET
MAX4271	10	$t_{ON} (ms) = 0.31 \times CTIM (nF)$	No retry available	
MAX4272	10	$t_{ON} (ms) = 0.31 \times CTIM (nF)$	320	$t_{RETRY} (ms) = 32 \times t_{ON} = 10 \times CTIM (nF)$
MAX4273*	10	$t_{ON} (ms) = 0.31 \times CTON (nF)$	320	$t_{RETRY} (ms) = 10 \times CTIM (nF)$

\*MAX4273 retry feature disabled by connecting CTIM to  $V_{IN}$ .

# 3V to 12V Current-Limiting Hot Swap Controllers with Autoretry, DualSpeed/BiLevel Fault Protection

**Table 6. “No-Overcurrent” Turn-On Timing (Startup Without Current Limit)**

DEVICE	C <sub>GATE</sub> (nF)	MOSFET t <sub>ON</sub> (ms)			MOSFET t <sub>OFF</sub> (ms)		
		V <sub>IN</sub> = 3V	V <sub>IN</sub> = 5V	V <sub>IN</sub> = 12V	V <sub>IN</sub> = 3V	V <sub>IN</sub> = 5V	V <sub>IN</sub> = 12V
Fairchild FDS6670A	0	0.22	0.16	0.19	0.07	0.13	0.145
	22	2.3	2	3.2	0.54	1.1	1.95
International Rectifier IRF7401	0	0.175	0.130	0.16	0.075	0.13	0.16
	22	1.9	1.8	3.5	0.54	1.1	2.0
Motorola MMSF5N03HD	0	0.101	0.074	0.073	0.033	0.067	0.085
	22	2.0	1.8	3.2	0.470	1.0	1.95

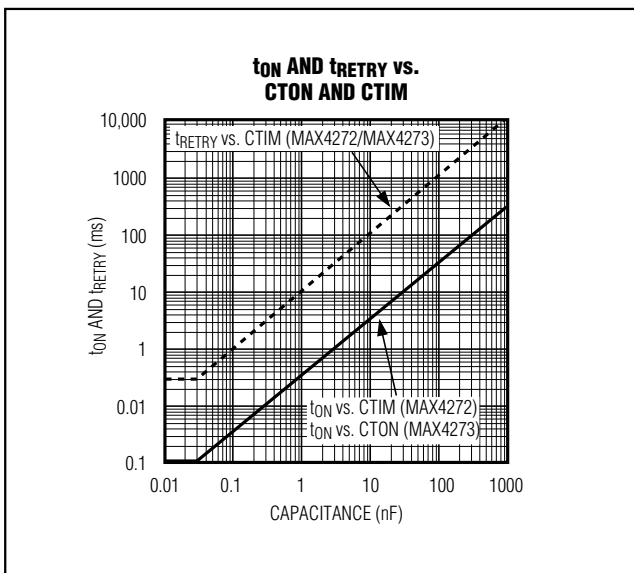

Figure 8. Startup and Retry Timeout

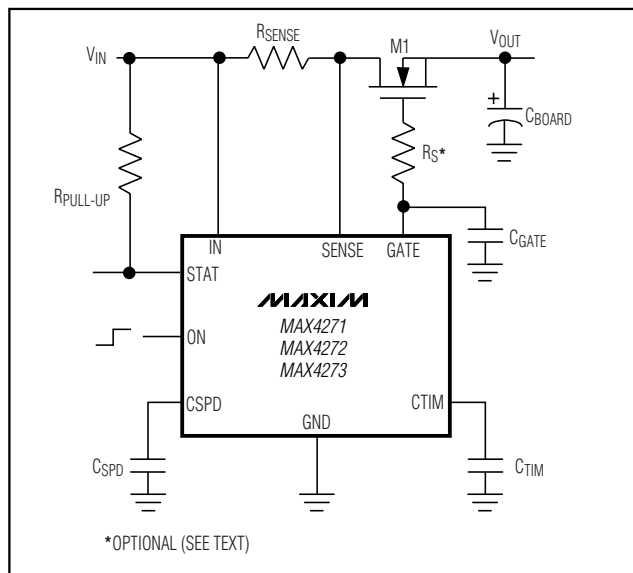

Figure 9. Operation with an External Capacitor

### Case B. Startup with Current Regulation

In applications where the board capacitance (C<sub>BOARD</sub>) at V<sub>OUT</sub> is high, the inrush current causes a voltage drop across R<sub>SENSE</sub> that exceeds the fast comparator threshold (V<sub>FC,TH</sub>). In this case, the current charging C<sub>BOARD</sub> can be considered constant and the turn-on time is determined by:

$$t_{ON} = C_{BOARD} \times V_{IN} / I_{FAST,SET}$$

where the maximum load current I<sub>FAST,SET</sub> = V<sub>FC,TH</sub> / R<sub>SENSE</sub>. Figure 3 shows the waveforms and timing diagrams for a startup transient with current regulation. (See Startup Time with C<sub>BOARD</sub> = 470μF in the *Typical Operating Characteristics*.) When operating under this condition, an external gate capacitor is not required. Adding an external gate capacitor at GATE to GND

reduces the regulated current ripple but increases t<sub>OFF</sub> by increasing the gate delay (t<sub>d</sub>) (Figure 4).

The actual startup time is determined by the longer of the two timings of Case A and Case B. Set the startup timer t<sub>START</sub> at 2 × t<sub>ON</sub> to guarantee enough time for the output voltage to settle; also take into consideration device parameter variation.

### Retry

The retry timer defines the dead time before the IC tries to restart a startup sequence following a fault detection. This feature is available on the MAX4272/MAX4273.

Before selecting the retry timer value, determine how long a temporary high-current fault condition may be present. In the event of a permanent fault, the automatic retry will effectively force current pulses through the

# 3V to 12V Current-Limiting Hot Swap Controllers with Autoretry, DualSpeed/BiLevel Fault Protection

MOSFET with a duty cycle equal to  $t_{ON}/t_{RETRY}$  and with a current equal to  $I_{FAST,SET}$ . Therefore, particular care has to be taken when choosing between immediate retry and board space needed to manage the power dissipation capabilities of the MOSFET (see *Thermal Considerations*). The duty cycle is fixed to 1/32 for the MAX4272, but can be varied in the MAX4273 by choosing CTIM and CSTART independently.

### Additional External Gate Capacitance (CEXT)

An external gate capacitance can be connected at GATE. This increases the time required to enhance the MOSFET and further limits the output rise time. In the MAX4271/MAX4272, connect the external capacitor between GATE and GND. In the MAX4273, the external capacitor can be connected between GATE and CEXT or GND. If the capacitor is connected to CEXT, it is discharged to ground during a slow comparator fault but it is left floating during a fast comparator fault; this allows the device to turn off the external MOSFET faster during critical faults. (CEXT is biased at  $V_{IN}$ ; therefore, use a nonpolarized capacitor). Capacitance connected from GATE to CEXT does little to decrease the regulated current ripple. Add a small capacitor (5nF) from GATE to GND. See the charging and discharging time vs.  $C_{GATE}$  graphs in the *Typical Operating Characteristics*.

### Slow-Comparator Response Time (CSPD)

The slow comparator threshold is set at 50mV, and its response time is determined by the external capacitor connected to CSPD (Figure 10).

A minimum response time of 20 $\mu$ s (typ) is achieved by leaving this pin floating. This time is determined internally and is not affected by stray capacitance at CSPD (up to 100pF).

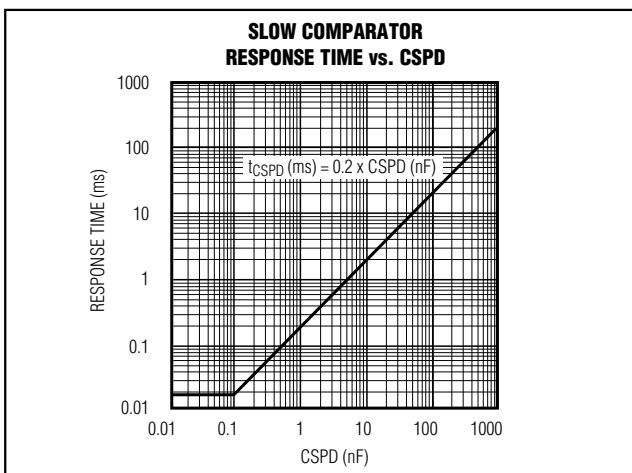

Figure 10. Slow Comparator Response Time vs. CSPD

Set the slow comparator response time to be longer than the normal operation load transients, (see *Slow Comparator*).

### ON and Reset Comparators

The ON comparator controls the ON/OFF function of these devices. The ON comparator is a precision voltage comparator that can be used for temperature monitoring or as an additional UVLO (Figure 11). The MAX4273 also features an uncommitted delayed comparator. This comparator can be used for voltage monitoring, power sequencing, or for generating a power-on reset signal for on-card microprocessors (Figure 12). Both comparator threshold voltages are set at  $V_{REF}/2 = 0.6V$  with a 3mV (typ) hysteresis.

The uncommitted comparator OUTC output is an open-drain output, and it is asserted low when its input voltage (INC) is below the threshold voltage. It goes into a high-impedance state 150ms after the voltage has risen above the threshold. The delay for negative-going edges is 10 $\mu$ s.

Figure 13 shows the MAX4273 used to monitor precisely the temperature of an external device such as the MOSFET. This configuration uses the uncommitted comparator to set the UVLO at a higher level by running its output into the ON comparator's input.

The ON comparator initiates startup when its input voltage ( $V_{ON}$ ) rises above the threshold voltage and turns off the MOSFET when the voltage falls below the threshold. The propagation delay is 10 $\mu$ s going high or low. The ON comparator is also used to reset the MAX4271/MAX4273 (when  $CTIM = V_{IN}$ ) after a fault condition (see *Latched/Autoretry*).

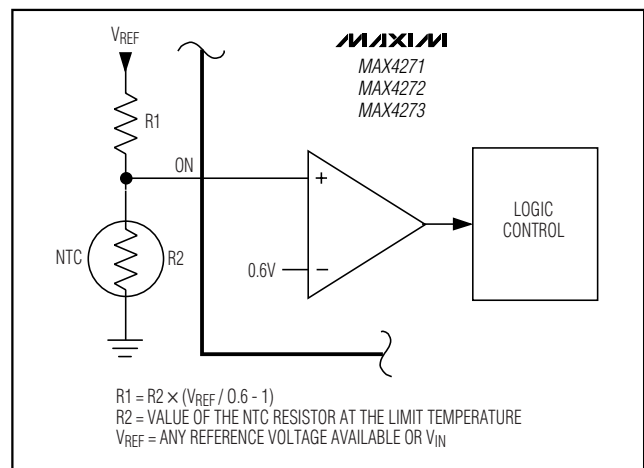

Figure 11. Temperature Monitoring and Protection

# 3V to 12V Current-Limiting Hot Swap Controllers with Autoretry, DualSpeed/BiLevel Fault Protection

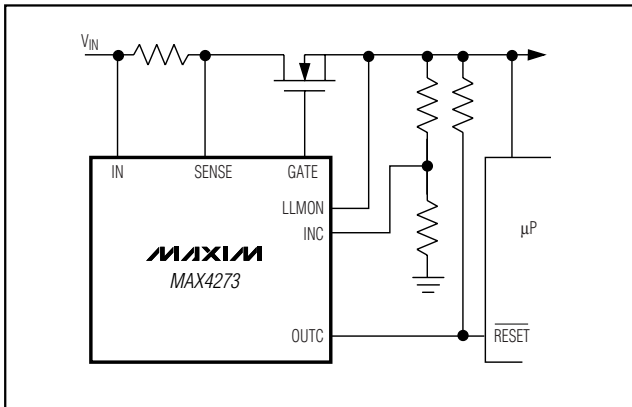

Figure 12. Power-On Reset

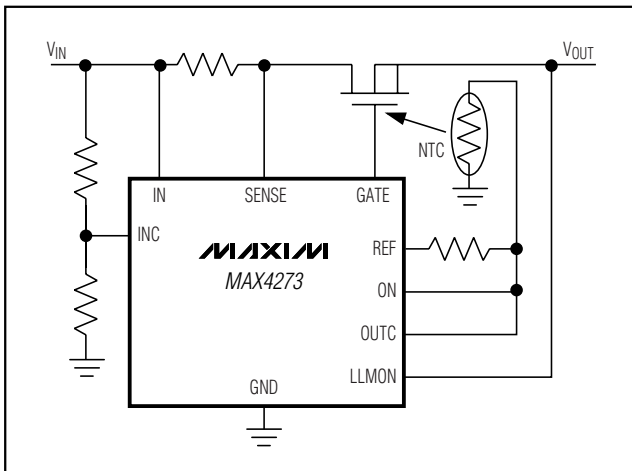

Figure 13. Power-On Reset and Temperature

The ON and INC comparator inputs and the STAT and OUTC can be pulled to voltages up to 14V independently of  $V_{IN}$ , thus allowing parts to be daisy-chained and not be turned on through the internal protection diodes. In some applications, it is useful to use connectors with staggered leads. In Figure 14, the ON pin forces the removable board to be powered up only when all connections are made.

### Auxiliary VCC

The auxiliary VCC is available on the MAX4273 and is used to sustain the input voltage required for the device to operate during a short-circuit condition on the board. When a short occurs, the main system power supply could collapse and the MAX4273 will not have enough voltage to keep the gate drive operational and turn off the external MOSFET. If the fault is not removed, the system could remain in a sustained short-circuit state.

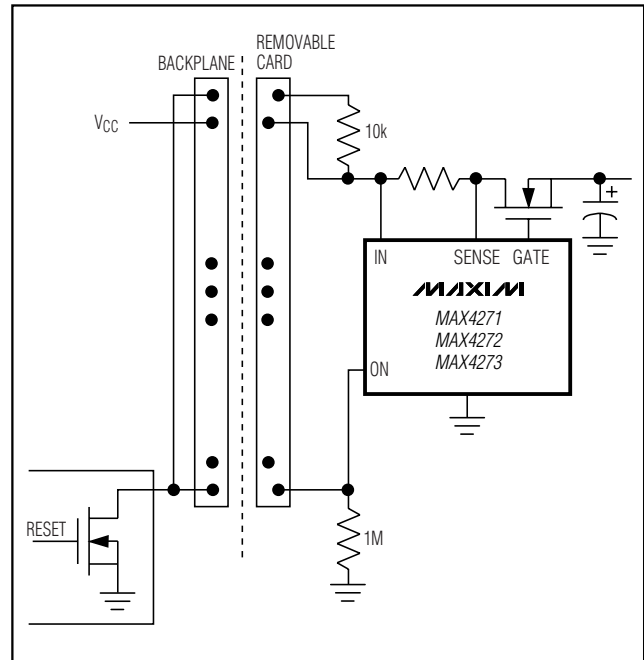

Figure 14. Fail-Safe Connector

Connect a  $1\mu\text{F}$  capacitor from the AUXVCC pin to GND. This capacitor will deliver the necessary energy to the gate drive until the MOSFET is turned off and the main supply recovers. The  $1\mu\text{F}$  capacitor is charged from  $V_{IN}$  through an internal switch during normal operation.

### Maximum Load Capacitance

The MAX4271/MAX4272/MAX4273 can be used on the backplane to regulate current upon insertion of a removable card (Figure 16). This allows multiple cards with different input capacitance to be inserted into the same slot even if the card doesn't have on-board Hot Swap protection.

The MAX4271/MAX4272/MAX4273 current-limiting feature is active during the startup period set by CTIM. The startup period can be triggered if  $V_{IN}$  is connected to ON through a trace on the card. Once  $t_{\text{START}}$  has expired (timed out), the load capacitance has to be charged or a fault condition is detected. To ensure startup with a fixed CTIM,  $t_{\text{START}}$  has to be longer than the time required to charge the board capacitance. The maximum load capacitance is calculated as follows:

$$C_{\text{BOARD}} < t_{\text{START}} \times I_{\text{FAST,SET}} / V_{\text{IN}}$$

# 3V to 12V Current-Limiting Hot Swap Controllers with Autoretry, DualSpeed/BiLevel Fault Protection

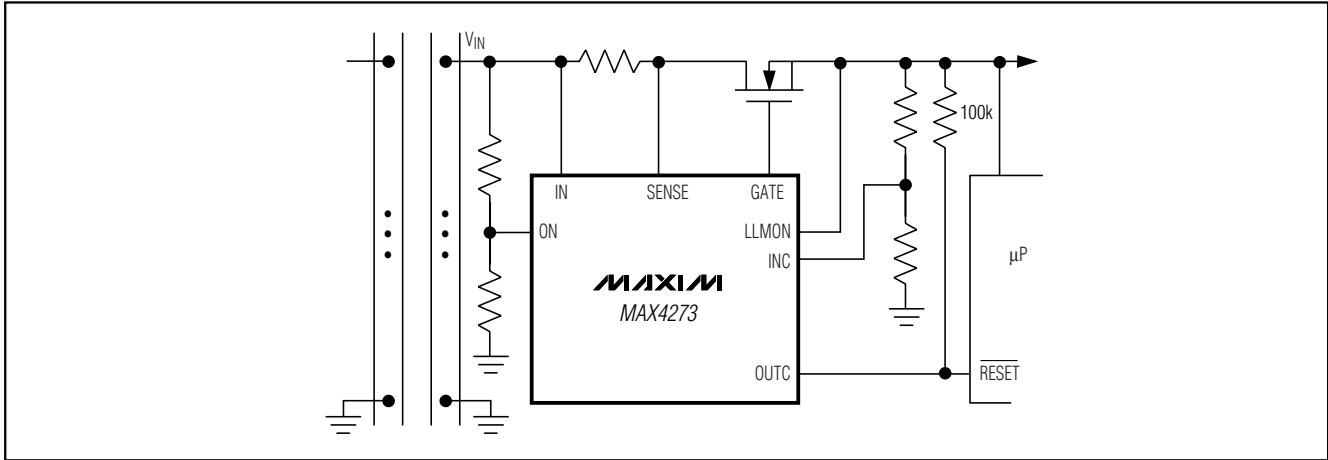

Figure 15. Adjustable Undervoltage Lockout and Output Voltage Reset Generator

### Input Transients

The voltage at  $V_{IN}$  must be above the UVLO during inrush and fault conditions. When a short condition occurs on the board, the fault current can be higher than the fast comparator current limit. The gate voltage is discharged immediately, but note that the MOSFET is not completely off until  $V_{GS} < V_{TH}$ . If the main system power supply collapses below UVLO, the MAX4271/MAX4272/MAX4273 will force the device to restart in startup mode with a 150ms delay once the supply has recovered. The main system power supply must be able to deliver this fault current without excessive voltage drop.

The MOSFET is turned off in a very short time; therefore, the resulting  $dv/dt$  can be considerable. The backplane delivering the power to the external card must have a fairly low inductance to limit the voltage transients caused by the removal of a fault. Bypassing the input with a small capacitor alleviates false UVLO trips due to these transients.

### MOSFET Thermal Considerations

During normal operation, the MOSFET dissipates little power, it is fully turned on, and its  $R_{DS(ON)}$  is minimal. The power dissipated in normal operation is  $P_D = I_{LOAD}^2 \times R_{DS(ON)}$ . A considerable amount of power is dissipated during the startup and turn-off transients. The design must take into consideration the worst-case scenario of a continuous short-circuit fault present on the board. Two cases need to be considered:

- 1) The single turn-on with the device latched after a fault (when using MAX4271 or MAX4273 in latched mode)

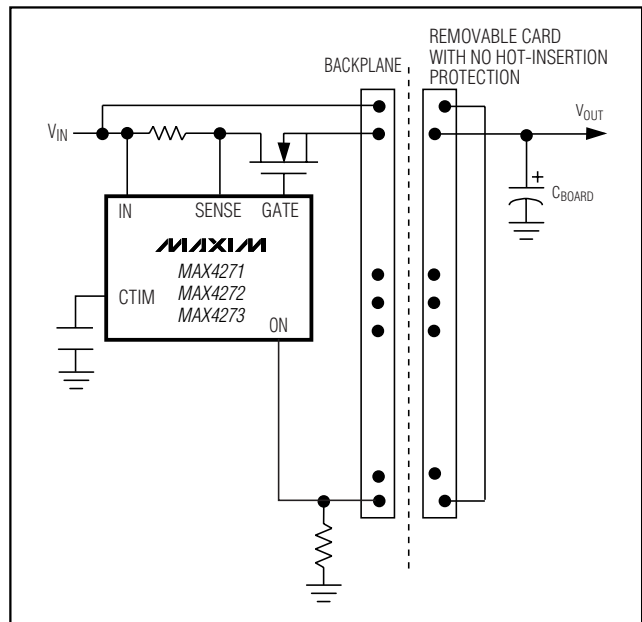

Figure 16. Using the MAX4271/MAX4272/MAX4273 on a Backplane

- 2) The continuous automatic retry (when using the MAX4272 or MAX4273 in retry mode)

MOSFET manufacturers typically include the package-normalized transient thermal resistance  $r_{\theta JA}(t)$  or  $r_{\theta JC}(t)$  that is determined by the startup time and the retry duty cycle ( $d = t_{START} / t_{RETRY}$ ).

The following equation is used to calculate the required transient thermal resistance:

$$R_{\theta JA}(t) = (T_{JMAX} - T_A) / P_{DMAX}(t)$$

# 3V to 12V Current-Limiting Hot Swap Controllers with Autoretry, DualSpeed/BiLevel Fault Protection

where  $P_{D_{MAX}}(t) = V_{IN} \times I_{FAULT}$  and the resulting  $R_{\theta JA} = R_{\theta JA}(t) / r_{\theta JA}(t)$ .  $R_{\theta JA}$  is the thermal resistance determined with a continuous load and by the layout or heatsink.

### Layout Considerations

To take full advantage of the switch response time to an output fault condition, it is important to keep all traces as short as possible and to maximize the high-current trace dimensions to reduce the effect of undesirable parasitic inductance. Place the MAX4271/MAX4272/MAX4273 close to the card's connector. Use a ground plane to minimize impedance and inductance. Minimize the current-sense resistor trace length (<10mm), and ensure accurate current sensing with Kelvin connections (Figure 17).

When the output is short circuited, the voltage drop across the external MOSFET becomes large. Hence, the power dissipation across the switch increases, as does the die temperature. An efficient way to achieve good power dissipation on a surface-mount package is to lay out two copper pads directly under the package on both sides of the board. Connect the two pads to the ground plane through vias, and use enlarged copper mounting pads on the top side of the board.

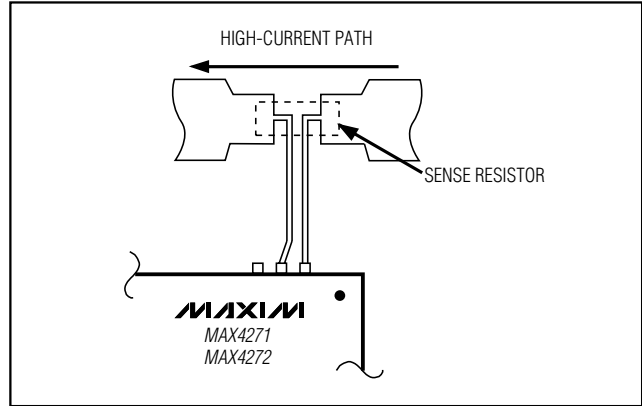

Figure 17. Kelvin Connections for the Current-Sense Resistors

### Ordering Information

PART	TEMP. RANGE	PIN-PACKAGE
MAX4271ESA	-40°C to +85°C	8 SO
MAX4272ESA	-40°C to +85°C	8 SO
MAX4273EEE*	-40°C to +85°C	16 QSOP
MAX4273ESE*	-40°C to +85°C	16 SO

\*Future products—contact factory for availability.

### Pin Configurations

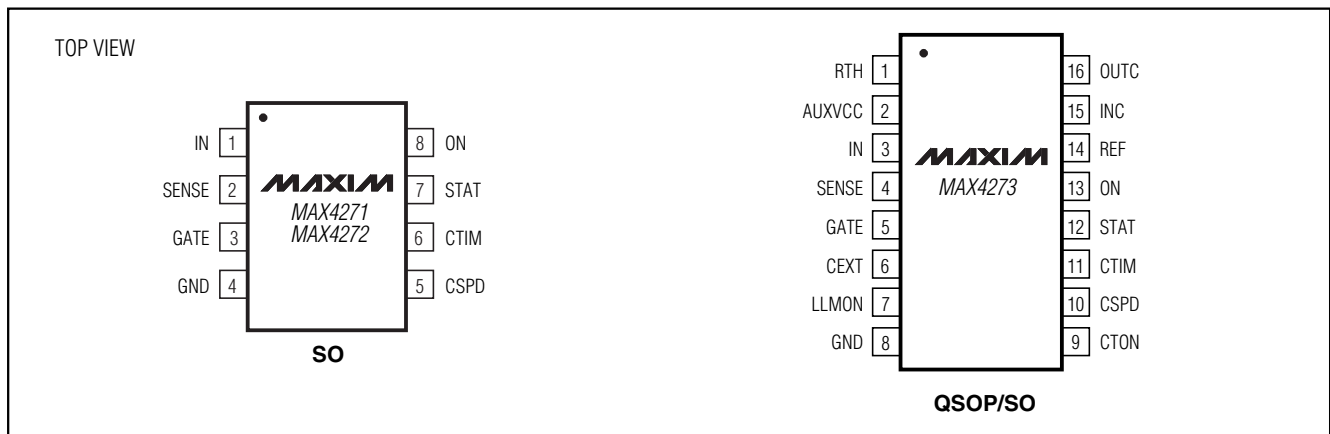

# 3V to 12V Current-Limiting Hot Swap Controllers with Autoretry, DualSpeed/BiLevel Fault Protection

## Package Information

MAX4271/MAX4272/MAX4273

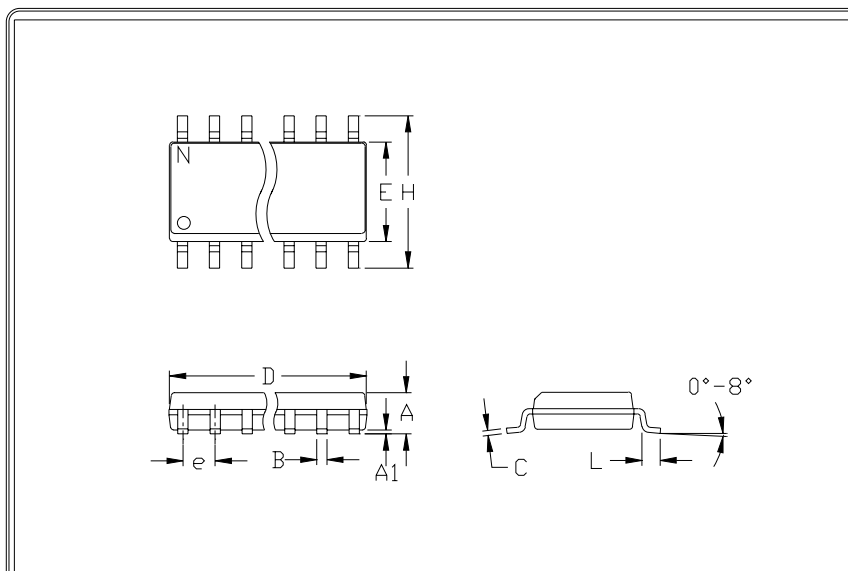

	INCHES		MILLIMETERS	
	MIN	MAX	MIN	MAX
A	0.053	0.069	1.35	1.75
A1	0.004	0.010	0.10	0.25
B	0.014	0.019	0.35	0.49
C	0.007	0.010	0.19	0.25
e	0.050		1.27	
E	0.150	0.157	3.80	4.00
H	0.228	0.244	5.80	6.20
h	0.010	0.020	0.25	0.50
L	0.016	0.050	0.40	1.27

	INCHES		MILLIMETERS		N	MS012
	MIN	MAX	MIN	MAX		
D	0.189	0.197	4.80	5.00	8	A
D	0.337	0.344	8.55	8.75	14	B
D	0.386	0.394	9.80	10.00	16	C

- NOTES:
1. D&E DO NOT INCLUDE MOLD FLASH
  2. MOLD FLASH OR PROTRUSIONS NOT TO EXCEED .15mm (.006")
  3. LEADS TO BE COPLANAR WITHIN .102mm (.004")
  4. CONTROLLING DIMENSION: MILLIMETER
  5. MEETS JEDEC MS012-XX AS SHOWN IN ABOVE TABLE
  6. N = NUMBER OF PINS



PACKAGE FAMILY OUTLINE: SOIC .150"

1/1

21-0041 A  
DOCUMENT CONTROL NUMBER REV



# 3V to 12V Current-Limiting Hot Swap Controllers with Autoretry, DualSpeed/BiLevel Fault Protection

## Package Information (continued)

QSOP-EPS

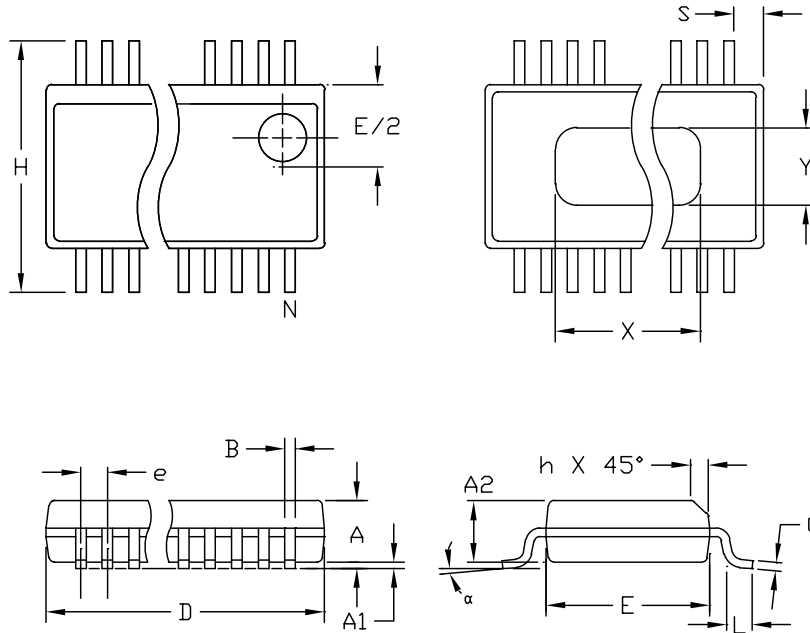

DIM	INCHES		MILLIMETERS	
	MIN	MAX	MIN	MAX
A	.061	.068	1.55	1.73
A1	.004	.0098	0.102	0.249
A2	.055	.061	1.40	1.55
B	.008	.012	0.20	0.31
C	.0075	.0098	0.191	0.249
D	SEE VARIATIONS			
E	.150	.157	3.81	3.99
e	.025 BSC		0.635 BSC	
H	.230	.244	5.84	6.20
h	.010	.016	0.25	0.41
L	.016	.035	0.41	0.89
N	SEE VARIATIONS			
X	SEE VARIATIONS			
Y	.071	.087	1.803	2.209
α	0°	8°	0°	8°

VARIATIONS:

DIM	INCHES		MILLIMETERS		N
	MIN.	MAX.	MIN.	MAX.	
D	.189	.196	4.80	4.98	16 AA
S	.0020	.0070	0.05	0.18	
X	.107	.123	2.72	3.12	
D	.337	.344	8.56	8.74	20 AB
S	.0500	.0550	1.270	1.397	
D	.337	.344	8.56	8.74	24 AC
S	.0250	.0300	0.635	0.762	
D	.386	.393	9.80	9.98	28 AD
S	.0250	.0300	0.635	0.762	
X	.271	.287	6.88	7.29	

NOTES:

1. D & E DO NOT INCLUDE MOLD FLASH OR PROTRUSIONS
2. MOLD FLASH OR PROTRUSIONS NOT TO EXCEED .006" PER SIDE.
3. HEAT SLUG DIMENSIONS X AND Y APPLY ONLY TO 16 AND 28 LEAD POWER-QSOP PACKAGES.
4. CONTROLLING DIMENSIONS: INCHES.

**MAXIM**

PROPRIETARY INFORMATION

TITLE:  
PACKAGE OUTLINE, QSOP, 150°, .025" LEAD PITCH

APPROVAL	DOCUMENT CONTROL NO.	REV	1/1
	21-0055	B	

Maxim cannot assume responsibility for use of any circuitry other than circuitry entirely embodied in a Maxim product. No circuit patent licenses are implied. Maxim reserves the right to change the circuitry and specifications without notice at any time.

24 \_\_\_\_\_ Maxim Integrated Products, 120 San Gabriel Drive, Sunnyvale, CA 94086 408-737-7600