

# 400mA Low Dropout Positive Voltage Regulator

## General Description

The BM9162 is a positive low dropout regulator designed for applications requiring low dropout performance at full rated current. The device is available in fixed output voltages of 3.3V and 3.5V. The BM9162 provides excellent regulation over line, load, and temperature variations.

The other features include low dropout performance at a maximum of 1.3V at 300mA, fast transient response, internal current limiting, and thermal shutdown protection of the output devices. The BM9162 is a three-terminal regulator compatible with industrial 78XX series and available in surface mount SOT-89 packages.

## Ordering Information

BM9162-□□

Output Voltage

33 : 3.3V

18 : 1.8V

30 : 3.0V

## Marking Information

For marking information, contact our sales representative directly or through a Bookly distributor located in your area, otherwise visit our website for detail.

## Features

- **Low Dropout, Maximum 1.3V at 300mA**
- **Fast Transient Response**
- **±2% Total Output Regulation**
- **Support high voltage input to +12V**
- **0.4% Load Regulation**
- **SOT-89 and TO-92 Packages**

## Applications

- 5V to 3.3V Linear Regulator
- Low Voltage Microcontroller, DSF, ..... etc. Power Supply , replace RT9162 / CM2830 / G910
- Linear Regulator for LAN Card and CD-ROM

## Pin Configurations

(TOP VIEW)

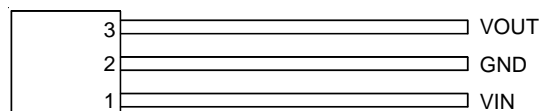

BM9162-3.3  
BM9162-3.0  
TO-92

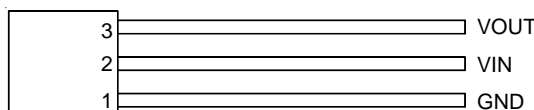

BM9162B-3.3  
BM9162B-3.0  
TO-92

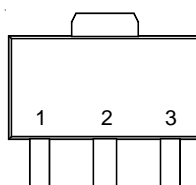

BM9162-3.3  
BM9162-1.8  
SOT-89

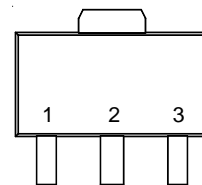

BM9162B-3.3  
BM9162B-1.8  
SOT-89

## Typical Application Circuit

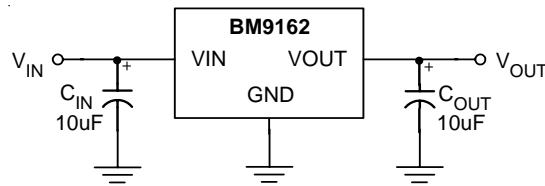

## Function Block Diagram

Pin Name	Pin Function
VOUT	Output Voltage
GND	Ground
VIN	Power Input

## Functional Pin Description

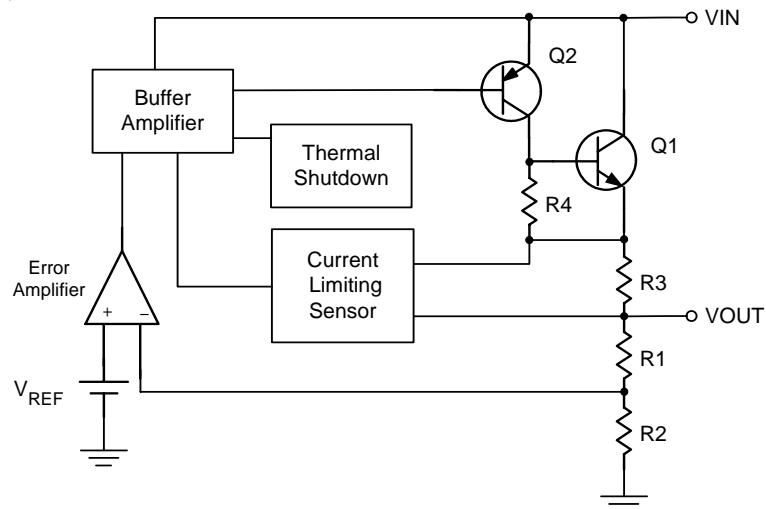

## Absolute Maximum Ratings

- Input Voltage ----- 15V
- Power Dissipation,  $P_D$  @  $T_A = 25^\circ\text{C}$ 
  - TO-92 ----- 0.6W
  - SOT-89 ----- 0.5W
- Package Thermal Resistance -----
  - TO-92,  $\theta_{JC}$  -----  $160^\circ\text{C/W}$
  - SOT-89,  $\theta_{JC}$  -----  $100^\circ\text{C/W}$
  - SOT-89,  $\theta_{JA}$  -----  $300^\circ\text{C/W}$
- Operating Junction Temperature Range -----  $-40^\circ\text{C}$  to  $125^\circ\text{C}$
- Storage Temperature Range -----  $-65^\circ\text{C}$  to  $150^\circ\text{C}$

## Electrical Characteristics

( $V_{IN} = 5.0\text{V}$ ,  $T_A = 25^\circ\text{C}$ , unless otherwise specified)

Parameter	Symbol	Test Conditions	Min	Typ	Max	Units
Output Voltage <sup>(1)</sup>	BM9162-33	$V_{OUT}$	3.235	3.300	3.365	V
	BM9162-30		2.950	3.000	3.060	
Line Regulation <sup>(1)</sup>	$\Delta V_{LINE}$	$V_{IN} = 5\text{V} - 15\text{V}$	--	0.1	0.4	%
Load Regulation <sup>(1)</sup>	$\Delta V_{LOAD}$	$I_L = 0 - 300\text{mA}$	--	0.2	0.4	%
Dropout Voltage <sup>(2)</sup>	$V_{DROP}$	$\Delta V_{OUT} = 1\%$	--	1.2	1.3	V
Current Limit	$I_{LIMIT}$		1000	--	--	mA
Quiescent Current	$I_Q$		-	7.5	15	mA
Temperature Coefficient	$T_C$		--	0.005	--	$\%/^\circ\text{C}$
Temperature Stability	$T_S$		--	0.5	--	%
RMS Output Noise <sup>(3)</sup>			--	0.003	--	$\%/V_{OUT}$

Notes:

(1) Low duty cycle pulse testing with Kelvin connections required.

(2) Dropout voltage is defined as the input to output differential at which the output voltage drops 1% below the value measured with a 2V differential.

(3) Bandwidth of 10 Hz to 10 kHz.

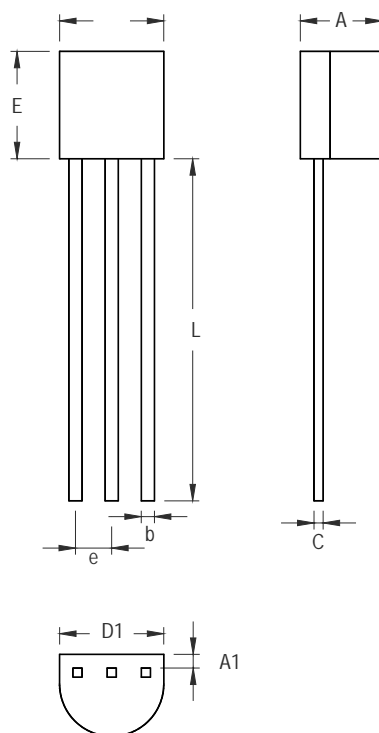

Symbol	Dimensions In Millimeters		Dimensions In Inches	
	Min	Max	Min	Max
A	3.175	4.191	0.125	0.165
A1	1.143	1.372	0.045	0.054
b	0.406	0.533	0.016	0.021
C	0.406	0.533	0.016	0.021
D	4.445	5.207	0.175	0.205
D1	3.429	--	0.135	--
E	4.318	5.334	0.170	0.210
e	1.143	1.397	0.045	0.055
L	12.700	--	0.500	--

**3-Lead TO-92 Plastic Package**

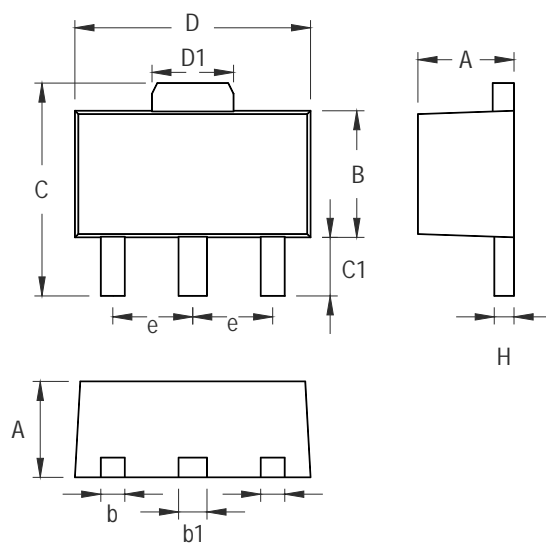

Symbol	Dimensions In Millimeters		Dimensions In Inches	
	Min	Max	Min	Max
A	1.397	1.600	0.055	0.063
b	0.356	0.483	0.014	0.019
B	2.388	2.591	0.094	0.102
b1	0.406	0.533	0.016	0.021
C	--	4.242	--	0.167
C1	0.787	1.194	0.031	0.047
D	4.394	4.597	0.173	0.181
D1	1.397	1.753	0.055	0.069
e	1.448	1.549	0.057	0.061
H	0.355	0.432	0.014	0.017

3-Lead SOT-89 Surface Mount Package