



MediaClock™ 27-MHz VCXO Clock Generator

Features

- Low-jitter, high-accuracy output
- VCXO with analog adjust
- 3.3V operation

Benefits

- Meets critical timing requirements in complex system designs
- Large ± 150 ppm range, better linearity

Part Number	Outputs	Input Frequency Range	Output Frequencies
CY24119	1	27-MHz pullable crystal per Cypress specification	One copy of 27-MHz (3.3V) positive slope VCXO curve
CY24119-1	1	27-MHz pullable crystal per Cypress specification	One copy of 27-MHz (3.3V) negative slope VCXO curve

Logic Block Diagram

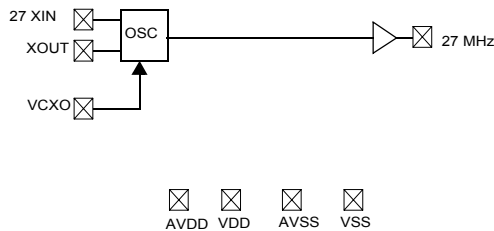

Pin Configuration

**CY24119,-1
8-pin SOIC**

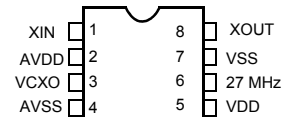

Pin Summary

Name	Pin Number	Description
A_{VDD}	2	Analog Voltage Supply
V_{DD}	5	Output Voltage Supply
A_{VSS}	4	Analog Ground
V_{SS}	7	Output Ground
X_{IN}	1	Reference Crystal Input
V_{CXO}	3	Analog Control for V_{CXO}
X_{OUT}	8	Reference Crystal Output
27 MHz	6	27-MHz Clock Output

Absolute Maximum Conditions

Parameter	Description	Min.	Max.	Unit
V_{DD}	Supply Voltage	-0.5	7.0	V
T_S	Storage Temperature ^[1]	-65	125	°C
T_J	Junction Temperature		125	°C
	Electrostatic Discharge	2		kV

Recommended Operating Conditions

Parameter	Description	Min.	Typ.	Max.	Unit
V_{DD}, A_{VDD}	Operating Voltage	3.14	3.3	3.47	V
T_A	Ambient Temperature	0		70	°C
C_{LOAD}	Max Load Capacitance			15	pF
f_{REF}	Reference Frequency	10	27	30	MHz
t_{PU}	Power-up time for all VDDs to reach minimum specified voltage (power ramps must be monotonic)	0.05		500	ms

DC Electrical Characteristics

Parameter	Name	Description	Min.	Typ.	Max.	Unit
I_{OH}	Output HIGH Current	$V_{OH} = V_{DD} - 0.5, V_{DD} = 3.3V$ (source)	12	24		mA
I_{OL}	Output LOW Current	$V_{OL} = 0.5, V_{DD} = 3.3V$ (sink)	12	24		mA
C_{IN}	Input Capacitance				7	pF
I_{IZ}	Input Leakage Current			5		μA
$f_{\Delta XO}$	V_{CXO} Pullability Range		-150		+150	ppm
V_{VCXO}	V_{CXO} Input Range		0		A_{VDD}	V
f_{VBW}	V_{CXO} Input Bandwidth			DC to 200		kHz
I_{DD}	Supply Current	Sum of Core and Output Current			13	mA

Pullable Crystal Specifications

Parameter	Description	Condition	Min.	Typ.	Max.	Unit
F_{NOM}	Nominal crystal frequency	Parallel resonance, fundamental mode, AT cut		27		MHz
C_{LNOM}	Nominal load capacitance			14		pF
R_1	Equivalent series resistance (ESR)	Fundamental mode			25	Ω

Note:

1. Not 100% tested.

Pullable Crystal Specifications (continued)

Parameter	Description	Condition	Min.	Typ.	Max.	Unit
R_3/R_1	Ratio of third overtone mode ESR to fundamental mode ESR	Ratio used because typical R_1 values are much less than the maximum spec.	3			
DL	Crystal drive level	No external series resistor assumed		0.5	2.0	mW
F_{3SEPHI}	Third overtone separation from $3.F_{NOM}$	High side	300			ppm
F_{3SEPLO}	Third overtone separation from $3.F_{NOM}$	Low side			-150	ppm
C_0	Crystal shunt capacitance				7	pF
C_0/C_1	Ratio of shunt to motional capacitance		180		250	
C_1	Crystal motional capacitance		14.4	18	21.6	pF

AC Electrical Characteristics ($V_{DD} = 3.3V$)

Parameter ^[1]	Name	Description	Min.	Typ.	Max.	Unit
DC	Output Duty Cycle	Duty Cycle is defined in <i>Figure 1</i> , 50% of V_{DD}	45	50	55	%
t_3	Rising Edge Slew Rate	Output Clock Rise Time, 20% – 80% of V_{DD}	0.8	1.4		V/ns
t_4	Falling Edge Slew Rate	Output Clock Fall Time, 80% – 20% of V_{DD}	0.8	1.4		V/ns
t_9	Clock Jitter	Peak-to-Peak Period Jitter			100	ps

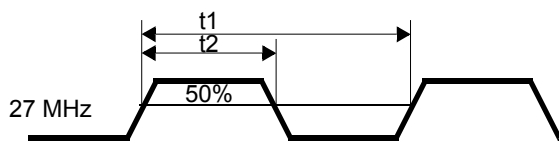
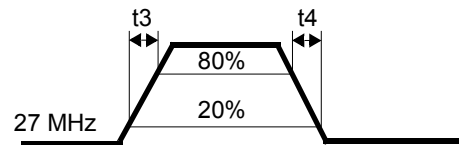
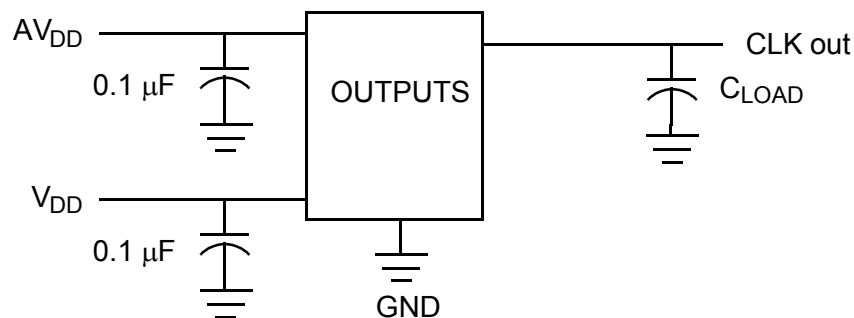
Figure 1. Duty Cycle Definition; DC = t_2/t_1

Figure 2. Rise and Fall Time Definitions

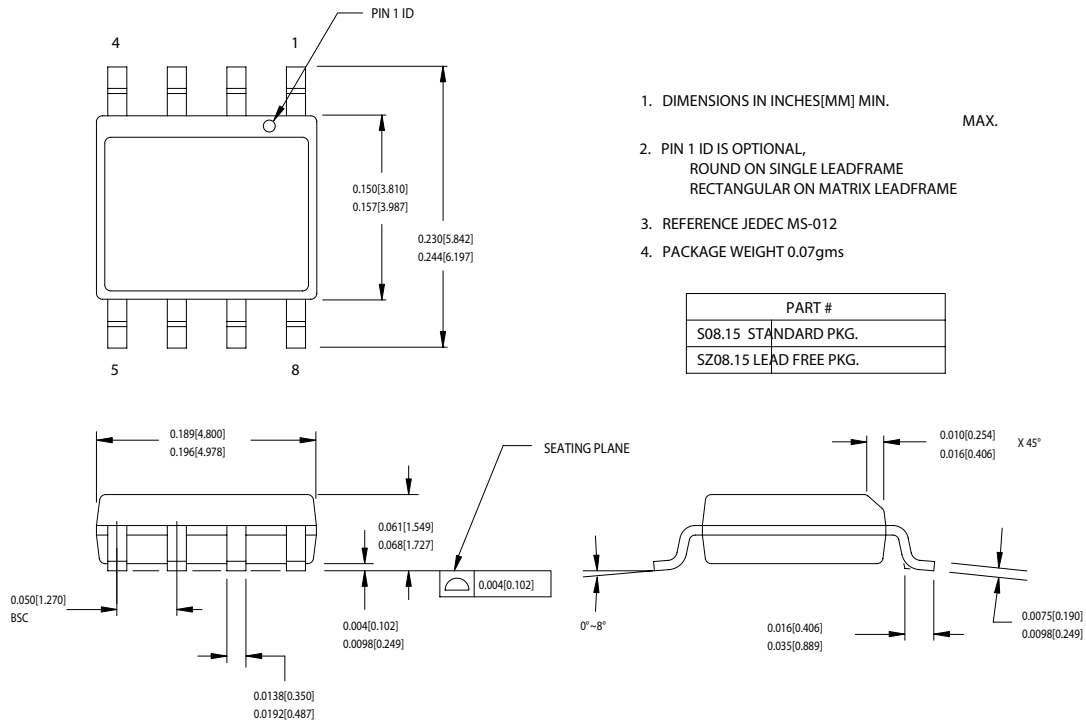
Test Circuit
Ordering Information

Ordering Code	Package Name	Package Type	Operating Range	Operating Voltage
CY24119SC	S8	8-pin SOIC	Commercial	3.3V
CY24119SCT	S8	8-pin SOIC – Tape and Reel	Commercial	3.3V
CY24119SC-1	S8	8-pin SOIC	Commercial	3.3V
CY24119SC-1T	S8	8-pin SOIC – Tape and Reel	Commercial	3.3V

Package Diagram
8-lead (150-Mil) SOIC S8

51-85066-°C

MediaClock is a trademark of Cypress Semiconductor. All product and company names mentioned in this document may be the trademarks of their respective holders.



Document History Page

Document Title: CY24119 MediaClock™ 27-MHz VCXO Clock Generator Document Number: 38-07200				
REV.	ECN NO.	Issue Date	Orig. of Change	Description of Change
**	111551	03/22/02	CKN	New Data Sheet
*A	121877	12/14/02	RBI	Power-up requirements added to Operating Conditions Information
*B	129724	10/09/03	IJA	Added -1 part, updated Crystal Spec Table