

TC8570AP/AF

Universal Asynchronous R/T

1. GENERAL DESCRIPTION

In micro-peripherals, i8251 is one of the serial communication LSI which have a function of the UART.

To accomplish the communication with telephone line, other circuits are needed. These are baud-generator which generator which generates clock signal for communication rate called baud-rate, and additional circuits which controls MODEM.

To UART TC8570AP/AF is one of communication LSI constructed with including these peripheral circuits. Internal Block Diagram is shown in FIG.3.1.

2. FEATURES

- 8 bit CPU bus compatible
- Full double buffering
- Four independent interrupt priority control functions
- Programmable Baud Generator to divide any input clock by 1 to $(2^{16}-1)$ and to generate the internal $16 \times$ clock
- Independent receiver clock input
- MODEM control function (CTS, RTS, DSR, DTR, CI, and DCD)
- 5 to 8 bit character length
- Even, odd, or non-parity bit generation and detection
- 1, 1.5, or 2 stop bit generation
- False start bit detection
- Break character transmission and detection
- Error detection (break, parity, overrun, and framing error)
- Complete status reporting capabilities
- Internal diagnostic capabilities (loopback for communication link, interrupt and receiver error simulation)
- All inputs are TTL compatible (except -MSEL input)
- Silicon-Gate CMOS construction
- Single +5V power supply
- 40 pin DIP or 44 pin mini FP

TC8570AP/AF-1

060489

351

3

COMMUNICATION CONTROLLER

3. SYSTEM CONFIGURATION of the UART

3.1 BLOCK DIAGRAM of the UART

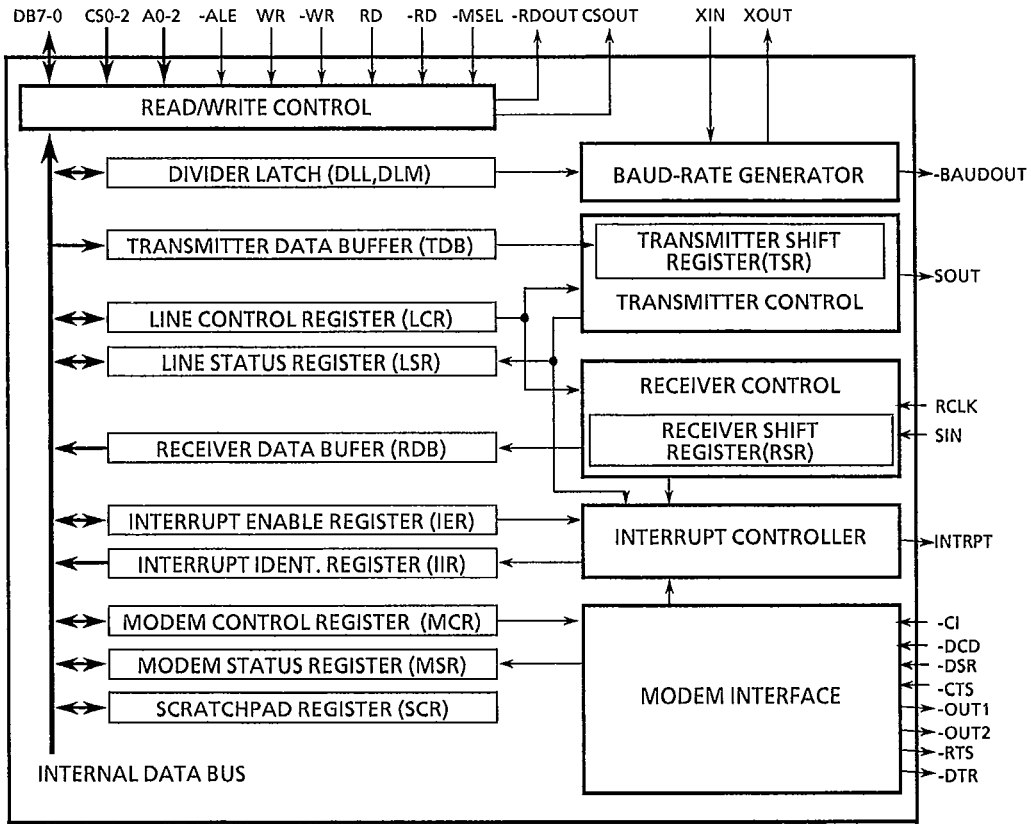

FIG.3.1 INTERNAL BLOCK DIAGRAM

TC8570AP/AF-2

060489

352

COMMUNICATION CONTROLLER

3.2 EXAMPLE of SYSTEM CONFIGURATION

TC8570AP/AF converts data character from the peripheral or the MODEM, serial to parallel, as well as converts data character from CPU, parallel to serial. These are basic function of the UART, such as adjusting data format match with communication protocols and evaluating data format of received matched or not with protocols.

As is shown in FIG.3.2 system configuration, the additional circuit in the UART gains maximum performance with used between CPU and MODEM equipment. CPU can read the status of UART any time even if its operation working. The status information is such for , the type and status of the transmitting operation that is just executing, and farther more information i.e. parity, overrun, framing error, interrupt of the break.

The complete MODEM control and processor interrupt function will be minimized occupancy of CPU for controlling communication line.

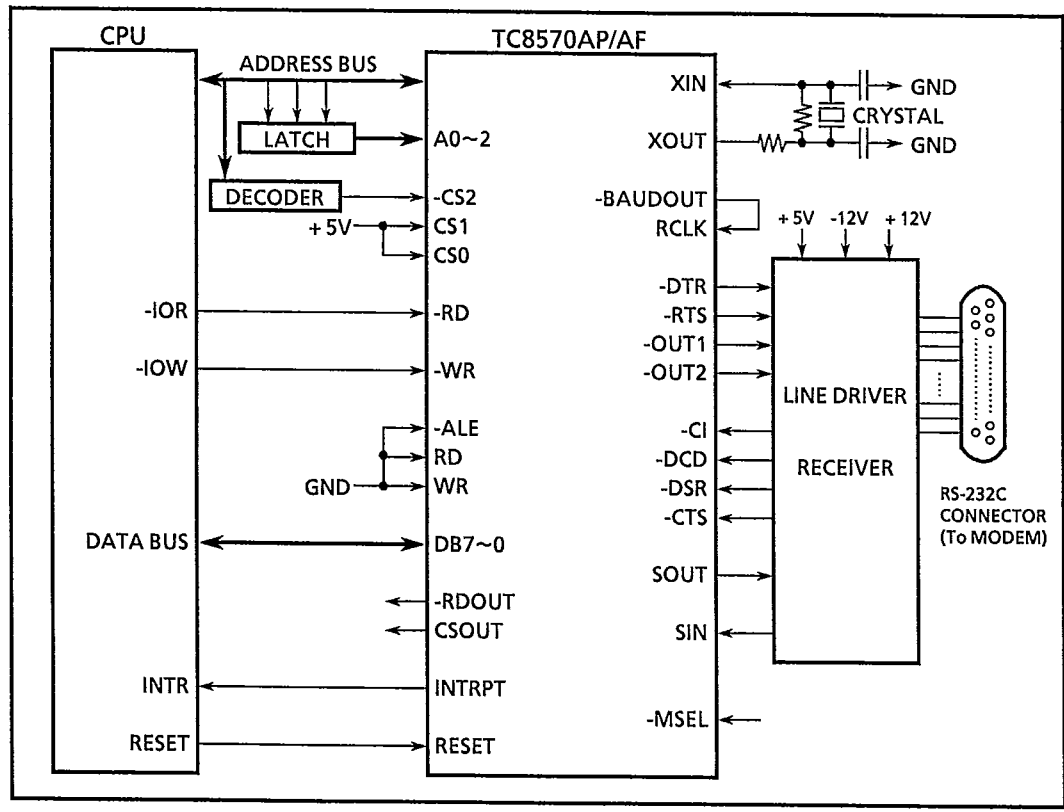

FIG.3.2 SYSTEM CONFIGURATION

TC8570AP/AF-3

060489

353



COMMUNICATION CONTROLLER

4. PIN DESCRIPTION

4.1 PIN CONFIGURATION

TC8570AP

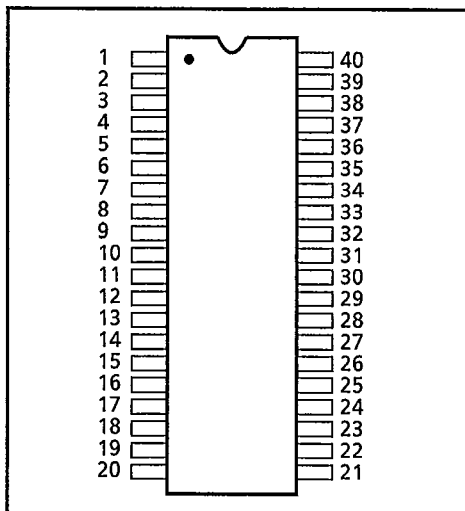

NO.	IO	PIN NAME	NO.	IO	PIN NAME
1	IO	DB0	21	I	-RD
2	IO	DB1	22	I	RD
3	IO	DB2	23	O	-RDOUT
4	IO	DB3	24	O	CSOUT
5	IO	DB4	25	I	-ALE
6	IO	DB5	26	I	A2
7	IO	DB6	27	I	A1
8	IO	DB7	28	I	A0
9	I	RCLK	29	I	-MSEL
10	I	SIN	30	O	INTRPT
11	O	SOUT	31	O	-OUT2
12	I	CS0	32	O	-RTS
13	I	CS1	33	O	-DTR
14	I	-CS2	34	O	-OUT1
15	O	-BAUDOUT	35	I	RESET
16	I	XIN	36	I	-CTS
17	O	XOUT	37	I	-DSR
18	I	-WR	38	I	-DCD
19	I	WR	39	I	-CI
20	G	GND	40	V	VCC

TC8570AF

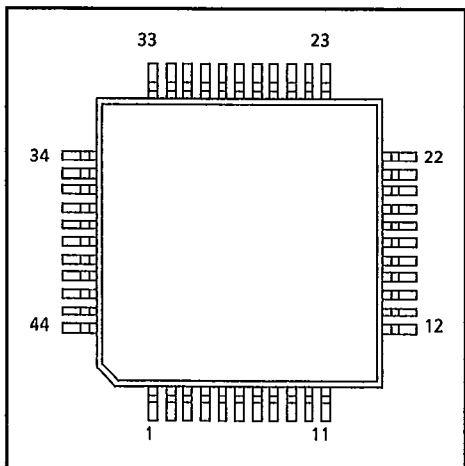

NO.	IO	PIN NAME	NO	IO	PIN NAME
1	IO	DB5	23	I	A2
2	IO	DB6	24	I	A1
3	IO	DB7	25	I	A0
4	I	RCLK	26	I	-MSEL
5		NC	27	O	INTRPT
6	I	SIN	28		NC
7	O	SOUT	29	O	-OUT2
8	I	CS0	30	O	-RTS
9	I	CS1	31	O	-DTR
10	I	-CS2	32	O	-OUT1
11	O	-BAUDOUT	33	I	RESET
12	I	XIN	34	I	-CTS
13	O	XOUT	35	I	-DSR
14	I	-WR	36	I	-DCD
15	I	WR	37	I	-CI
16	G	GND	38	V	VCC
17	V	VCC	39	V	VCC
18	I	-RD	40	IO	DB0
19	I	RD	41	IO	DB1
20	O	-RDOUT	42	IO	DB2
21	O	CSOUT	43	IO	DB3
22	I	-ALE	44	IO	DB4

TC8570AP/AF-4

060489

354

COMMUNICATION CONTROLLER

4.2 PIN FUNCTION

note) The number in parentheses shows pin number of the Flat package

NO.	PIN NAME	IO	FUNCTION
1 (40)	DB0	IO	These terminals are 8 bit bidirectional bus to communicate between the UART and the CPU.
2 (41)	DB1	IO	
3 (42)	DB2	IO	
4 (43)	DB3	IO	
5 (44)	DB4	IO	
6 (1)	DB5	IO	
7 (2)	DB6	IO	
8 (3)	DB7	IO	
9 (4)	RCLK	I	This terminal is input of the 16X baud rate clock for the receiver section of the UART.
10 (6)	SIN	I	This terminal is serial data input from the communication link (peripheral device, MODEM, or Data Set).
11 (7)	SOUT	O	This terminal is the composite serial data output for the communication link (peripheral device, MODEM, or Data Set). SOUT is set to the marking (logic 1) state upon a RESET operation. If the co-operation mode (-MSEL = 0) is selected, SOUT is set to the marking when -ALE is "L".
12 (8)	CS0	I	This signal indicates that the chip is selected. It can not be done data communication between the UART and the CPU until CSOUT signal is "H"
13 (9)	CS1	I	
14 (10)	-CS2	I	
15 (11)	-BAUDOUT	O	This terminal supplies the 16 X clock signal of baud rate clock to the transfer section of the UART. The clock rate is equal to the oscillator frequency divided by the value in the Baud Generator Divider Latches. -BAUDOUT may be used to the standard frequency of receiver section by tying this terminal to RCLK.
16 (12)	XIN	I	This terminal connects to crystal resonator or external clock signal.
17 (13)	XGUT	O	This output is inverted signal of XIN and connected to crystal resonator.
18 (14)	-WR	I	When WR is "High" or -WR is "Low" while the chip is selected, it permits the CPU to write data or control words into the selected register of the UART.
19 (15)	WR	I	
20 (16)	GND	G	Ground terminal of IC. Connect to system ground.
21 (18)	-RD	I	When RD is "High" or -RD is "Low" while the chip is selected, it permits the CPU to read data or status information from the selected register of the UART.
22 (19)	RD	I	

TC8570AP/AF-5

060489

355

COMMUNICATION CONTROLLER

note) The number in parentheses shows pin number of the Flat package

NO.	PIN NAME	IO	FUNCTION
23 (20)	-RDOUT	O	Whenever the CPU is reading data from the UART, this signal is "Low". This signal can use the enable signal to connect the transceiver to the external data bus.
24 (21)	CSOUT	O	This signal indicates that the chip is selected. It cannot be done data communication between the UART and the CPU until CSOUT signal is "High".
25 (22)	-ALE	I	This input is used to latch the address (A0, A1, A2) and chip select (CS0, CS1, -CS2) signals with the edge from "Low" to "High". When the address and chip select signals are stable for the duration of a read or a write operation, -ALE ties permanently "Low". If these are not stable, it is necessary to be active "Low". When the co-operation mode (-MSEL = 0) is selected, this terminal is not the latch signal but the output enable signals of DB7-0 and SOUT.
26 (23)	A2	I	These inputs are used to select the register of the UART for the duration of a read or a write operation.
27 (24)	A1	I	
28 (25)	A0	I	
29 (26)	-MSEL	I	When this terminal is "High" or open, the UART is normal operation. If it terminal ties permanently "Low" and RESET is "High", it changes the co-operation mode. At this time, -ALE loses a part of latch signals for address (A0, A1, A2) and chip select (CS0, CS1, -CS2). Also, SOUT is "High" during -ALE is "Low" and the data bus becomes high-impedance state. The other outputs are not influenced.
30 (27)	INTRPT	O	This terminal is set to "High" whenever any one of the following interrupt types has an active "High" condition and is enabled via the Interrupt Enable register : Receiver Error, Received Data Ready, Transmitter Data Buffer Empty, and MODEM Status. INTRPT signal is reset to "Low" upon the appropriate interrupt service or a RESET operation.
31 (29)	-OUT2	O	This terminal is an output released for user. It can set to an active "Low" by programming -OUT2 of the MODEM Control Register to "High" upon a RESET operation. -OUT2 signal is forced to its inactive "High" during loop mode operation.
32 (30)	-RTS	O	When this terminal is "Low", it informs the MODEM or Data Set that the UART is ready to transmit data. -RTS signal is set to "High" upon a RESET operation. -RTS signal is forced to its inactive "High" during loop mode operation.
33 (31)	-DTR	O	When this terminal is "Low", it informs the MODEM or Data Set that the UART is ready to communicate. -DTR signal is set to "High" upon a RESET operation. -DTR signal is forced to its inactive "High" during loop mode operation.

TC8570AP/AF-6

060489

356

COMMUNICATION CONTROLLER

note) The number in parentheses shows pin number of the Flat package

NO.	PIN NAME	IO	FUNCTION
34 (32)	-OUT1	O	This terminal is an output released for user. It can set to an active "Low" by programming -OUT1 of the MODEM Control Register to "High". -OUT1 signal is set to "High" upon a RESET operation. -OUT1 signal is forced to its inactive "High" during loop mode operation.
35 (33)	RESET	I	When this input is "High", all registers (except of the Receiver Data, Transmitter Data Buffer, and Baud Generator) and control logic are cleared. Also, output signal of MODEM are cleared. (TABLE 5.1.9)
36 (34)	-CTS	I	-CTS signal is a MODEM control function input. The CPU can know its condition by reading CTS of the MODEM Status Register. DCTS of the MODEM Status Register indicates whether -CTS input has changed since the previous reading of the MODEM Status Register. note) If MODEM Status Interrupt is enabled, whenever CTS of the MODEM Status Register, an interrupt is generated.
37 (35)	-DSR	I	When this input is "Low", it indicates that the MODEM or Data Set is ready to establish the communication link and transfer data with the UART. -DSR signal is a MODEM control function input. The CPU can know its condition by reading DSR of the MODEM Status Register. DDSR of the MODEM Status Register indicates whether -DSR input has changed since the previous reading of the MODEM Status Register.
38 (36)	-DCD	I	When this input is "Low", it indicates that the data carrier has been detected by the MODEM or Data Set. -DCD signal is MODEM control function input. The CPU can know its condition by reading DCD of the MODEM Status Register. DDCD of the MODEM Status Register indicates whether -DCD input has changed since the previous reading of the MODEM Status Register.
39 (37)	-CI	I	When this input is "Low", it indicates that the ringing signal has been received by the MODEM or Data Set. -CI signal is a MODEM control function input. The CPU can know its condition by reading CI of the MODEM Status Register. TECI of the MODEM Status Register indicates whether -CI input condition has changed from "Low" to "High" since the previous reading of the MODEM Status Register.

3

TC8570AP/AF-7

060489

357

COMMUNICATION CONTROLLER

5. FUNCTIONAL DESCRIPTION

5.1 INTERNAL REGISTERS

The UART includes ten registers. The user can access and control any of the UART register via the CPU. These register are used to control the operations of the UART and to transmit and receive data. (TABLE 5.1)

TABLE 5.1 INTERNAL REGISTERS

ADDRESS	REGISTER/ BUFFER NAME	SYMBOL	DATA BIT									
			DB7	DB6	DB5	DB4	DB3	DB2	DB1	DB0		
0(DLAB = 0)	Receiver Data Buffer *R	RDB	RD7	RD6	RD5	RD4	RD3	RD2	RD1	RD0		
0(DLAB = 0)	Transmitter Data Buffer *W	TDB	TD7	TD6	TD5	TD4	TD3	TD2	TD1	TD0		
1(DLAB = 0)	Interrupt Enable Register	IER	x	x	x	x	EMSI	ELSI	ETDBEI	ERDRI		
2	Interrupt Ident. Register *R	IIR	x	x	x	x	x	IID1	IID0	INTF		
3	Line Control Register	LCR	DLAB	SBRK	STCP	EP5	PEN	STB	WLS1	WLS0		
4	MODEM Control Register	MCR	x	x	x	LOOP	OUT2	OUT1	RTS	DTR		
5	Line Status Register	LSR	x	TEMP	TDBE	BD	FE	PE	OE	RDR		
6	MODEM Status Register	MSR	DCD	CI	DSR	STC	DDCD	TECI	DDSR	DCTS		
7	Scratchpad Register	SCR	D7	D6	D5	D4	D3	D2	D1	D0/CS1		
0(DLAB = 1)	Divider Latch (LS)	DLL	B7	B6	B5	B4	B3	B2	B1	B0		
1(DLAB = 1)	Divider Latch (MS)	DLM	B15	B14	B13	B12	B11	B10	B9	B8		

x : Always "0"

* note The RDB and IIR are read-only registers. The TDB is write-only register. Any other registers are possible to read and write, but writing to the Status Registers (LSR, MSR) during the communication are not recommended as these operations are used for diagnostic testing by the interrupt and the simulation of the receiver error.

COMMUNICATION CONTROLLER

5.1.1 LINE CONTROL REGISTER (LCR)

The user can specify the format of the asynchronous data communications exchange via the Line Control Register. In addition to specify the format, the user can refer the contents of the Line Control Register for inspection of communication link. this construction can be simple the system program, and eliminate the need for separate storage in system memory of the line characteristics.

A2	A1	A0	DB7	DB6	DB5	DB4	DB3	DB2	DB1	DB0
0	1	1	DLAB	SBRK	STCP	EPS	PEN	STB	WLS1	WLS0

WLS0,WLS1 (Word Length Select Bit 0-1)

These 2 bits specify the number of bits in each transmitted or received serial character.

WLS1	WLS0	WORD LENGTH
0	0	5 BIT
0	1	6 BIT
1	0	7 BIT
1	1	8 BIT

STB (Number of Stop Bit)

This bit specifies the number of stop bit in each transmitted or received serial character. If STB is "Low, one stop bit is generated in the transmission data. If STB is "High", 1.5 stop bits are generated when a 5-bit word length is selected. If STB is "High", 2 stop bits are generated when either a 6, 7, or 8-bit word length is selected. The receiver checks the first stop bit only, regardless of the number of stop bits selected.

STB	WLS1	WLS0	NUMBER OF STOP BIT
1	0	0	1.5
	0	1	2
	1	0	
	1	1	
0	×	×	1

× : NO RELATION

PEN (Parity Enable)

This bit is the Parity Enable bit. When PEN is "High", a parity bit is generated (transmit data) or checked (receive data) between the last data word bit and stop bit of the serial data.

TC8570AP/AF-9

060489

359

COMMUNICATION CONTROLLER

EPS (Even Parity Select)

This bit is the Even Parity Select bit. When PEN is "High" and EPS is "Low", an odd number of logic 1's is transmitted or checked in the data word bits and parity bit. When PEN is "High" and EPS is "High", an even of logic 1's is transmitted or checked.

STB	WLS1	KIND OF PARITY BIT
1	1	Even Parity
	0	Odd Parity
0	1	Non Parity
	0	

STCP (Stick Parity)

This bit is the Stick Parity bit. When PEN is "High" and STCP is "High", the parity bit (if EPS is "High") is logic 1, or (if EPS is "Low") is logic 0.

PEN	STCP	WLS1	PARITY BIT
1	1	1	0
		0	1

SBRK (Set Break)

This bit is the Break Control bit. When SBRK is "High", the Serial Output (SOUT) is forced to the Spacing (logic 0) state. The break is disabled by setting SBRK to "Low". The Break Control bit (SBRK) influences only on SOUT and has no effect on the transmitter logic.

DLAB (Divider Latch Access Bit)

This bit is the Divider Latch Access Bit. It must be set to a logic 1 to access the Divider Latches of the Baud Generator during a read or a write operation. It must be set to a logic 0 to access the Receiver Data Buffer, the Transmitter Data Buffer, or the Interrupt Enable Register.

COMMUNICATION CONTROLLER**5.1.2 PROGRAMMABLE BAUD GENERATOR**

The UART contents the programmable Baud Generator. The programmable Baud Generator divides input clock by the value that is set by the two 8-bit Divider Latches (DDL, DDM). The divided frequency is the output signal of -BAUDOUT as 16 X clock of baud rate. The baud rate of transfer data is the frequency of 1/16 output

A2	A1	A0	DB7	DB6	DB5	DB4	DB3	DB2	DB1	DB0
0	0	1	B15	B14	B13	B12	B11	B10	B9	B8
0	0	0	B7	B6	B5	B4	B3	B2	B1	B0

(DLAB = 1)

The frequency of the output signal (baud rate X 16) of -BAUDOUT is follows :

$$\text{BAUD16X} = B15 \times 2^{15} + B14 \times 2^{14} + B13 \times 2^{13} + B12 \times 2^{12} + B11 \times 2^{11} + \dots \\ \dots + B4 \times 2^4 + B3 \times 2^3 + B2 \times 2^2 + B1 \times 2^1 + B0$$

These 16-bit Divider Latches must be set up during initialization in order to ensure the normally occurrence of the baud rate. Upon writing either upper or lower of the Divider Latches, the divided value is immediately loaded into the baud counter. And then, baud counter begins to count.

3

COMMUNICATION CONTROLLER

5.1.3 LINE STATUS REGISTER (LSR)

This 8-bit register provides the status information to CPU about the data transfer.

A2	A1	A0	DB7	DB6	DB5	DB4	DB3	DB2	DB1	DB0
1	0	1	—	TEMP	TDBE	BD	FE	PE	OE	RDR

RDR (Received Data Ready)

This bit indicates the Received Data Ready. RDR is set to a logic 1 whenever a complete incoming character has been received and transmitted into the Receiver Data Buffer. RDR is reset to a logic 0 by reading the data in the Receiver Data Buffer.

OE (Overrun Error)

This bit indicates the Overrun Error. If next characters are received into Receiver Data Buffer before the contents of Receiver Data Buffer has been read by the CPU, OE is set to a logic 1. It is reset to a logic 0 whenever the CPU reads the contents of the Line Status Register.

PE (Parity Error)

This bit indicates the Parity Error. It means that when the Parity Enable bit (PEN) of the Line Control Register is set, the received data did not have the correct even or odd parity as selected by the Even Parity Select bit (EPS) of the Line Status Register. PE is set to a logic 1 upon detection of a parity error and is reset to a logic 0 whenever the CPU reads the contents of the Line Status Register.

FE (Framing Error)

This bit indicates the Framing Error. It means that the received data did not have a valid stop bit. FE is set to a logic 1 whenever the stop bit of the received data is detected as a zero (Spacing level). It is reset to a logic 0 whenever the CPU reads the contents of the Line Status Register.

BD (Break Detect)

This bit indicates the Break Detect. BD is set to a logic 1 whenever the received data input is held in the Spacing (logic 0) state for a full transmission time (that is, the total of start bit + data bits + parity bit + stop bit). It is reset to a logic 0 whenever the CPU reads the contents of the Line Status Register.

*note : OE, PE, FE, and BD are the error conditions that produce the Receiver Status Interrupt whenever any of the corresponding conditions are detected.

TC8570AP/AF-12

060489

362

TDBE (Transmitter Data Buffer Empty)

This bit indicates the Transmitter Data Buffer Empty. It means that the UART is ready to accept a new character to transfer. When the character is transmitted from the Transmitter Data Buffer to the Transmitter Shift Register, TDBE is set to a logic 1 and the UART occurs the Transmitter Data Buffer by the CPU.

TEMP (Transmitter Empty)

This bit indicates the Transmitter Empty. TEMP is set to a logic 1 whenever the Transmitter Data Buffer and Transmitter Shift Register are both empty. It is reset to a logic 0 whenever either the Transmitter Data buffer or Transmitter Shift Register receives a data character.

Bit7

This bit is always set to logic 0.



COMMUNICATION CONTROLLER

5.1.4 INTERRUPT IDENTIFICATION REGISTER (IIR)

The UART has an interrupt function which allows for complete flexibility in interfacing to all popular microprocessors presently available. The UART prioritizes interrupts into four level to realize minimum expense of software during the data transfer. The prioritizing of interrupt are follows

- Priority 1 : Receiver Line Status
- Priority 2 : Received Data Ready
- Priority 3 : Transmitter Data Buffer Empty
- Priority 4 : MODEM Status

This information indicates a prioritized interrupts pending. The type of interrupt are stored in the Interrupt Identification Register. The Interrupt Identification Register addressed during chip select time, freezes the highest priority interrupt pending and no other interrupts are acknowledged until the particular interrupt is serviced by the CPU. (TABLE 5.1.4)

A2	A1	A0	DB7	DB6	DB5	DB4	DB3	DB2	DB1	DB0
0	1	0	—	—	—	—	—	IID1	IID0	INTF

INTF (Interrupt Flag)

This bit can be used in either a hardware prioritization or polled environment to indicate whether an interrupt is occurred or not. When this bit set to a logic 0, an interrupt is occurred and the contents of the Interrupt Identification Register may be used as a pointer to the appropriate interrupt service routine. When INTF is set to a logic 1, no interrupt is pending and polling (if used) continues.

IID0, IID1 (Interrupt ID Bit 0, Bit 1)

These two bits indicate the kind of the interrupts occurred with the priority.

Bit3-7

These five bits are always set to a logic 0.

TABLE 5.1.4 INTERRUPT CONTROL FUNCTIONS

IIR			PRIORITY LEVEL	INTERRUPT TYPE	INTERRUPT SOURCE	INTERRUPT RESET CONTROL
IID1	IID0	INTF				
0	0	1	—	None	—	
1	1	0	1	Receiver Line Status	Overrun Error Parity Error Framing Error Break Interrupt	Reading the LSR
1	0	0	2	Received Data Ready	Receiver Data Available	Reading the RDB
0	1	0	3	Transmitter Data Buffer Empty	TDB Empty	Reading the IIR or writing the TDB
0	0	0	4	MODEM Status	Clear to Send Data Set Ready Call Indicator Data carrier Detect	Reading the MSR

5.1.5 INTERRUPT ENABLE REGISTER (IER)

This register enables the four types

A2	A1	A0	DB7	DB6	DB5	DB4	DB3	DB2	DB1	DB0
0	0	1	—	—	—	—	EMSI	ELSI	ETDBEI	ERDRI

(DLAB = 0)

ERDRI (Enable Received Data Ready Interrupt)

When this bit sets to a logic 1, the Received Data Ready Interrupt is enabled.

ETDBEI (Enable Transmitter Data Buffer Empty Interrupt)

When this bit sets to a logic 1, the Transmitter Data Buffer Empty Interrupt is enabled.

ELSI (Enable Receiver Line Status Interrupt)

When this bit sets to logic 1, the Receiver Line Status Interrupt is enabled.

EMSI(Enable MODEM Status Interrupt)

When this bit sets to a logic 1, the MODEM Status Interrupt is enabled.

Bit4-7

These four bits are always set to a logic 0.

COMMUNICATION CONTROLLER

5.1.6 MODEM CONTROL REGISTER (MCR)

This register controls the interface a MODEM or a Data Set or a peripheral device emulating a MODEM.

A2	A1	A0	DB7	DB6	DB5	DB4	DB3	DB2	DB1	DB0
1	0	0	—	—	—	LOOP	OUT2	OUT1	RTS	DTR

DTR (Data Terminal Ready)

This bit controls the Data Terminal Ready (-DTR) output. When this bit is set to a logic 1, the -DTR output is forced to a logic 0. When this bit is reset to a logic 0, the -DTR output is forced to a logic 1.

RTS (Request to Send)

This bit controls the Request to Send (-RTS) output. When this bit is set to a logic 1, the -RTS output is forced to a logic 0. When this bit is reset to a logic 0, the -RTS output is forced to a logic 1.

OUT1 (Output 1)

This bit controls the Output 1 (-OUT 1) signal released for user. When this bit is set to a logic 1, the -OUT 1 output is forced to a logic 0. When this bit is reset to a logic 0, the -OUT 1 output is forced to a logic 1.

OUT2 (Output 2)

This bit controls the Output 2 (-OUT 2) signal released for user. When this bit is set to a logic 1, the -OUT 2 output is forced to a logic 0. When this bit is reset to a logic 0, the -OUT 2 output is forced to a logic 1.

LOOP

This bit supplies a local loop back feature for diagnostic testing of the UART. When LOOP set to a logic 1, the following occurs :

The transmitter Serial Output (SOUT) is set to the marking (logic 1) state, the Serial Input (SIN) is disconnected, the output of the Transmitter Shift Register is "loop back" into the Receiver Shift Register input internally, the four MODEM control inputs (-CTS, -DSR, -DCD, and -CI) are disconnected, the four MODEM control outputs (-DTR, -RTS, -OUT1, and -OUT2) are internally connected to the four MODEM control inputs, and the MODEM control output pins are forced to their inactive states (high).

In the diagnostic mode, the transmitted data is immediately received. This feature allows the CPU to verify the transmitting and receiving data paths of the UART. In the diagnostic mode, the receiver and transmitter interrupts are fully operational. The MODEM Control Interrupts are also operational, but the interrupts source are now the lower four bits of the MODEM Control Register, which are internally connected, instead of the four MODEM control inputs. The interrupts are still controlled by the Interrupt Enable Register.

Bit5-7

These three bits are always set to a logic 0.

TC8570AP/AF-16

060489

366

COMMUNICATION CONTROLLER

5.1.7 MODEM STATUS REGISTER (MSR)

This register provides the current status of the control lines from the MODEM or peripheral device. In addition to this current status information, the four bits of the MODEM Status Register provide information. These bits are set to a logic 1 whenever a control input from MODEM changes state. They are reset to a logic 0 whenever the CPU reads the MODEM Status Register.

A2	A1	A0	DB7	DB6	DB5	DB4	DB3	DB2	DB1	DB0
1	1	0	DCD	CI	DSR	CTS	DDCD	TECI	DDSR	DCTS

DCTS (Delta Clear to Send)

This bit indicates the change of -CTS input. It indicates that -CTS input to the chip has changed state since the last time read by the CPU.

DDSR (Delta Data Set Ready)

This bit indicates the change of -DSR input. It indicates that -DSR input to the chip has changed state since the last time read by the CPU.

TECI (trailing Edge Call Indicator)

This bit indicates the trailing edge of -CI input. It indicates that -CI input to the chip has changed from an ON (logic 1) to an OFF (logic 0) condition.

DDCD (Delta Data Carrier Detect)

This bit indicates the changed state since the last time read by the CPU.

*note ... Whenever DCTS, DDSR, TEDI, or DDCD is set to a logic 1, MODEM Status Interrupt is generated.

CTS (Clear to Send)

This bit is the complement of the -CTS input. If LOOP of the MODEM Status Register is set to a logic 1, this bit is equivalent to RTS in the MODEM Control Register.

DSR (Data Set Ready)

This bit is the complement of the -DSR input. If LOOP of the MODEM Status Register is set to a logic 1, this bit is equivalent to DTR in the MODEM Control Register.

CI (Call Indicator)

This bit is the complement of the -CI input. If LOOP of the MODEM Status Register is set to a logic 1, this bit is equivalent to OUT1 in the MODEM Control Register.

DCD (Data Carrier Detect)

This bit is the complement of the -DCD input. If LOOP of the MODEM Status Register set to a logic 1, this bit is equivalent to OUT2 in the MODEM Control Register.

COMMUNICATION CONTROLLER

5.1.8 SCRATCHPAD REGISTER (SCR)

This Read/Write Register does not entirely control the UART. It is intended as a Scratchpad Register to be used by the programmer to hold data temporarily. When the data output control mode (-MSEL=0) is selected, the contents of CS1 appears D0 bit. At this time, CS1 becomes a 1 bit input port.

A2	A1	A0	DB7	DB6	DB5	DB4	DB3	DB2	DB1	DB0
1	1	0	D7	D6	D5	D4	D3	D2	D1	D0/CS1

5.1.9 RESET FUNCTION

In reset state, all register (except Receiver Data Buffer (RDB), Transmit Data Buffer (TDB), and Baud-rate generator) and control logic as well as the output signal for MODEM, are cleared.

REGISTER/BUFFER/SIGNAL (REGISTER BIT)		RESET CONDITION								RESET CONTROL
		7	6	5	4	3	2	1	0	
Interrupt Enable Register	(IER)	-	-	-	-	0	0	0	0	Reset Input
Interrupt Ident. Register	(IIR)	-	-	-	-	-	0	0	1	Reset Input
Line Control Register	(LCR)	0	0	0	0	0	0	0	0	Reset Input
MODEM Control Register	(MCR)	0	0	0	0	0	0	0	0	Reset Input
Line Status Register	(LSR)	0	1	1	0	0	0	0	0	Reset Input
MODEM Status Register	(MSR)	x	x	x	x	0	0	0	0	Reset Input
Serial Input	(SOUT)	High								Reset Input
Receiver Line Status Interrupt		Low								Reset Input/LSR Read
Received Data Ready Interrupt		Low								Reset Input/RDB Read
Transmitter Data Buffer Empty Interrupt		Low								IIR Read/TDB Write
MODEM Status Interrupt		Low								Reset Input/MSR Read
-OUT1, -OUT2, -RTS, -DTR		ALL High								Reset Input

- : Always 0 x : External Input

COMMUNICATION CONTROLLER

6. ELECTRICAL CHARACTERISTICS

6.1 ABSOLUTE MAXIMUM RATINGS

PARAMETER	SYMBOL	RATING	UNIT
Supply Voltage	V_{CC}	-0.5 ~ +7.0	V
Input Voltage	V_{IN}	-0.5 ~ $V_{CC} + 0.5$	V
Operating Temperature	T_{opr}	-40 ~ +85	°C
Storage Temperature	T_{stg}	-65 ~ +125	°C

6.2 DC CHARACTERISTICS

 $T_a = -40^{\circ}\text{C} \sim +85^{\circ}\text{C}$, $V_{CC} = 5\text{V} \pm 10\%$

PARAMETER	SYMBOL	CONDITION	MIN.	MAX.	UNIT
Input Low Voltage	V_{IL}		-0.5	0.8	V
Input High Voltage	V_{IH}		2.2	V_{CC}	V
Output Low Voltage	V_{OL}	$I_{OL} = 2.2\text{mA}$	-	0.4	V
Output High Voltage	V_{OH}	$I_{OH} = -1.1\text{mA}$	$V_{CC} - 0.4$	-	V
Input Leak Current	I_{IL}	$V_{IN} = 0\text{V} \sim V_{CC}$	-10	+10	μA
Supply Current	I_{CC}	$f_{CLK} = 4\text{MHz}$	-	5	mA

TC8570AP/AF-19

060489

369

COMMUNICATION CONTROLLER

6.3 AC CHARACTERISTICS

Ta = -40°C ~ +85°C, V_{CC} = 5V ± 10%

PARAMETER	SYMBOL	MIN.	TYP.	MAX.	UNIT
Clock Cycle Time	t _{XC}	250			ns
Clock "High" Pulse Width	t _{XH}	120			ns
Clock "Low" Pulse Width	t _{XL}	120			ns
-ALE Pulse Width	t _{EE}	60			ns
Address Set Time	t _{AE}	60			ns
Address Hold Time	t _{EA}	25			ns
Chip Select Setup Time	t _{CE}	60			ns
Chip Select Hold Time	t _{EC}	0			ns
RD, -RD Pulse Width	t _{RR} , -RD	125			ns
Read Cycle Delay Time	t _{RCD}	175			ns
Read Cycle Time	t _{RC}	360			ns
-RDOU Delay Time (from RD, -RD)	t _{RO}			80	ns
Data Delay Time (from RD, -RD)	t _{RD}			125	ns
Data Float Delay Time	t _{DF}	0		100	ns
WR, -WR Pulse Width	t _{WW}	100			ns
Write Cycle Delay Time	t _{WCD}	200			ns
Write Cycle Time	t _{WC}	360			ns
Data Setup Time (from WR, -WR)	t _{DW}	40			ns
Data Hold Time (from WR, -WR)	t _{WD}	40			ns
CSOUT Delay Time	* t _{CO}			100	ns
Address Setup Time (from RD, -RD)	* t _{AR}	60			ns
Address Hold Time (from RD, -RD)	* t _{RA}	20			ns
Chip Select Setup Time (from RD, -RD)	* t _{CSR}	50			ns
Chip Select Hold Time (from RD, -RD)	* t _{RCS}	20			ns
Address Setup Time (from WR, -WR)	* t _{AW}	60			ns
Address Hold Time (from WR, -WR)	* t _{WA}	20			ns
Chip Select Setup Time (from WR, -WR)	* t _{CSW}	50			ns
Chip Select Hold Time (from WR, -WR)	* t _{WCS}	20			ns
RESET Pulse Width	t _{RST}	5			μs
-BAUDOUT Delay Time	t _{BAU}			125	ns
-BAUDOUT "Low level" Width (f _X = 2MHz ÷ 2)	t _{LW}	425			ns
-BAUDOUT "High level" Width (f _X = 3MHz ÷ 3)	t _{HW}	330			ns

TC8570AP/AF-20

060489

370

COMMUNICATION CONTROLLER

PARAMETER	SYMBOL	MIN.	TYP.	MAX.	UNIT
Receiver					
RDB , LSR Read to INTRPT Reset Delay Time	t_{RRI}			1	μ s
Stop Bit to INTRPT Delay Time	t_{RSI}	1		1	RCLK
Transmitter					
TDB Write to INTRPT Reset Delay Time	t_{TWI}			175	ns
Stop Bit to INTRPT (TDBE) Delay Time	t_{TSI}	8		8	-BAUDOUT
IIR R ead to INTRPT (TDBE) Reset Delay Time	t_{TRI}			250	ns
Initial RDB Write to INTRPT Delay Time	t_{SI}	16		32	BAUDOUT Cycles
Initial TDRE INT Reset to Transmit Start Delay Time	t_{IRS}	8		24	BAUDOUT Cycles
MODEM Control					
MCR Write to MODEM Output Delay Time	t_{MWO}			200	ns
MODEM Input Change to INTRPT Delay Time	t_{MSI}			250	ns
MSR Read to INTRPT Reset Delay Time	t_{MRI}			250	ns

* : Applicable only when -ALE is tied low.

TC8570AP/AF-21

060489

371

COMMUNICATION CONTROLLER

6.3.1 EXTERNAL LOAD CONDITIONS of TERMINAL

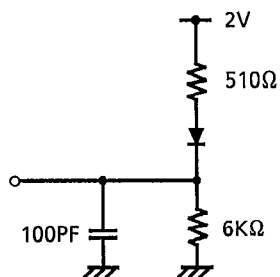

6.3.2 AC INPUT WAVEFORM for TEST

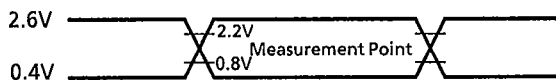

6.3.3 EXTERNAL CLOCK INPUT

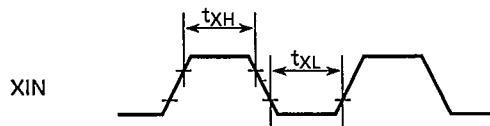

COMMUNICATION CONTROLLER

WRITE CYCLE

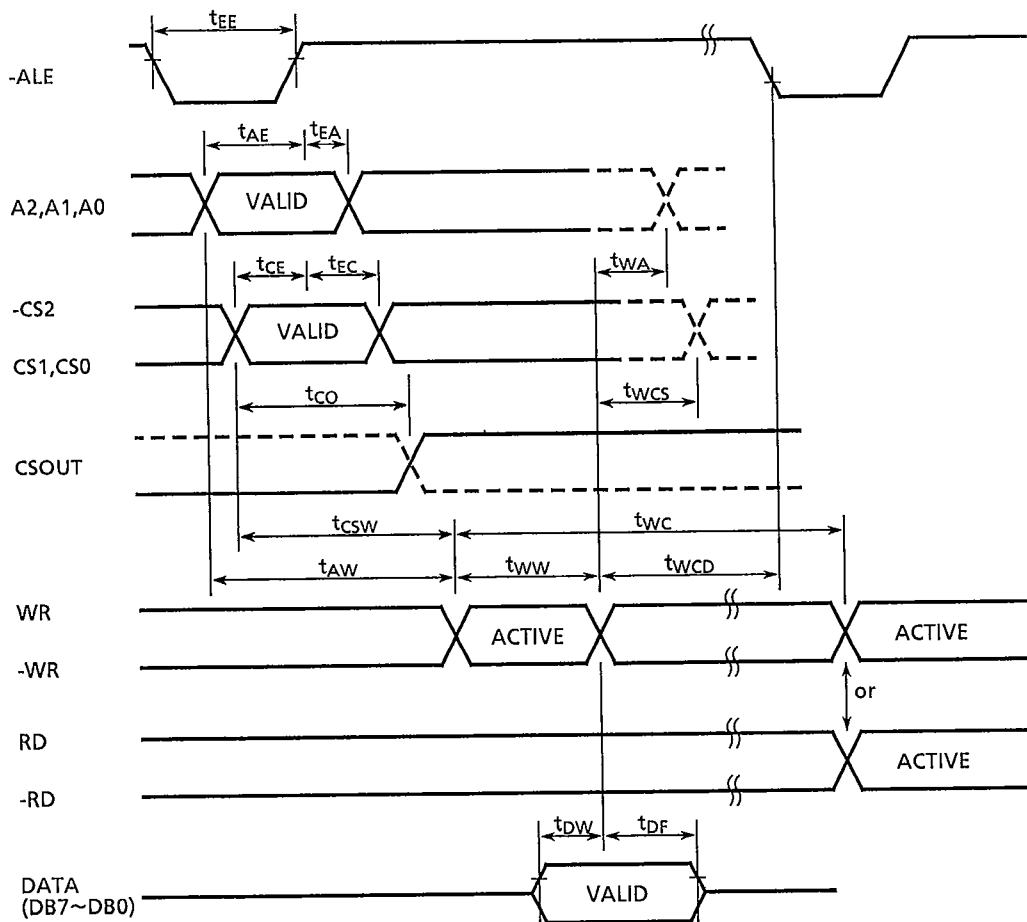

TC8570AP/AF-24

060489

374

COMMUNICATION CONTROLLER

-BAUDOUT TIMING

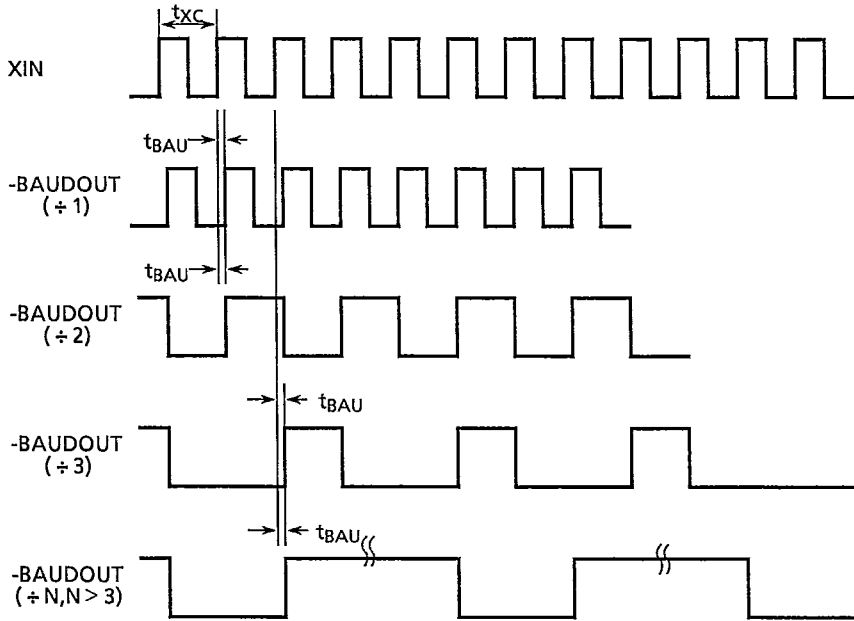

RECEIVER TIMING

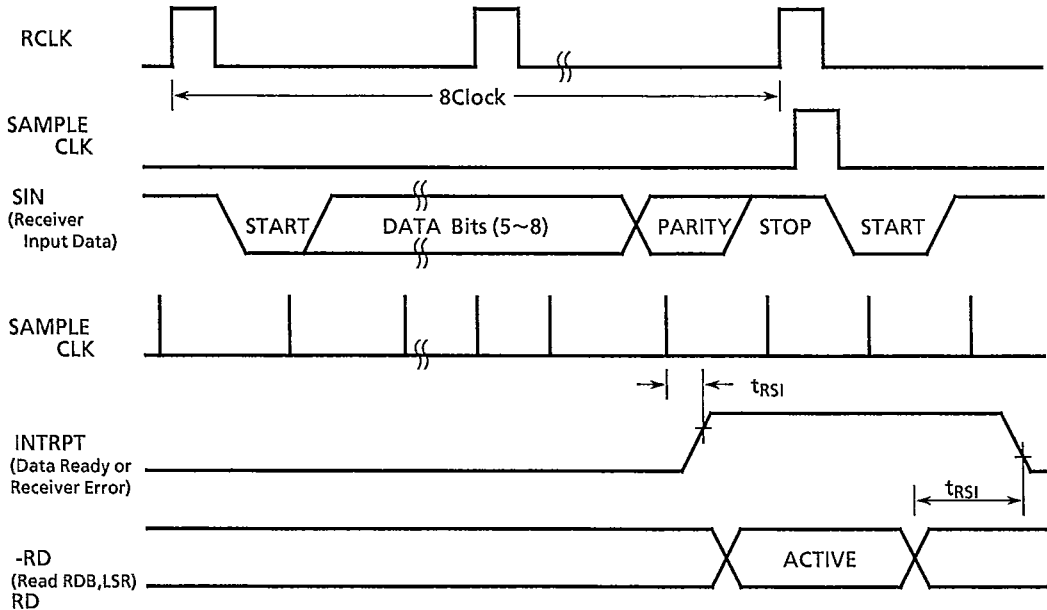

3

TC8570AP/AF-25

060489

375

COMMUNICATION CONTROLLER

TRANSMITTER TIMING

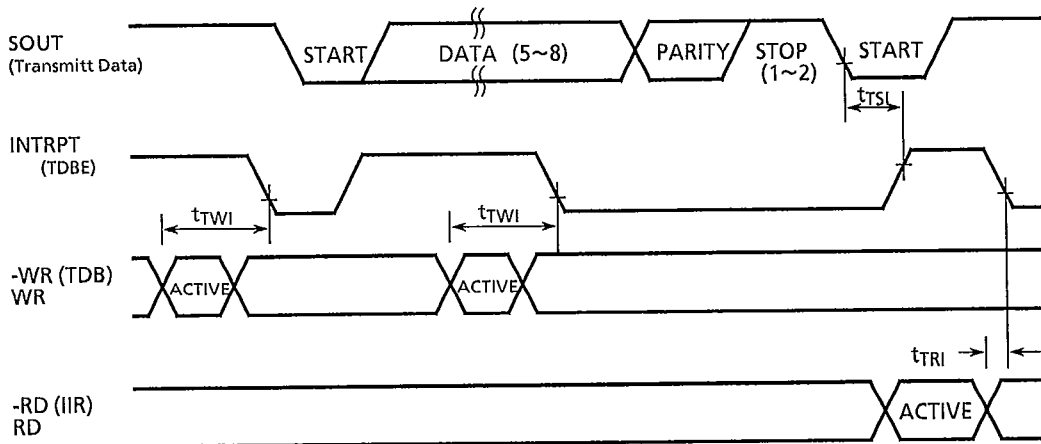

MODEM CONTROL TIMING

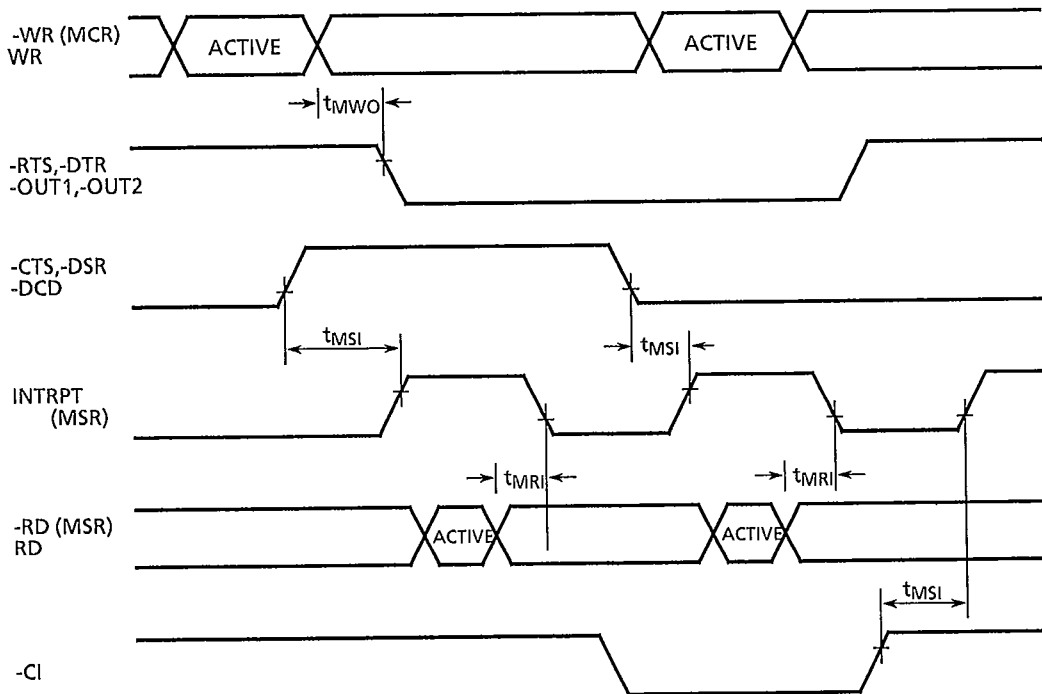

TC8570AP/AF-26

060489

376

7. PACKAGE DIMENSION

DIP40-P-600

UNIT : mm

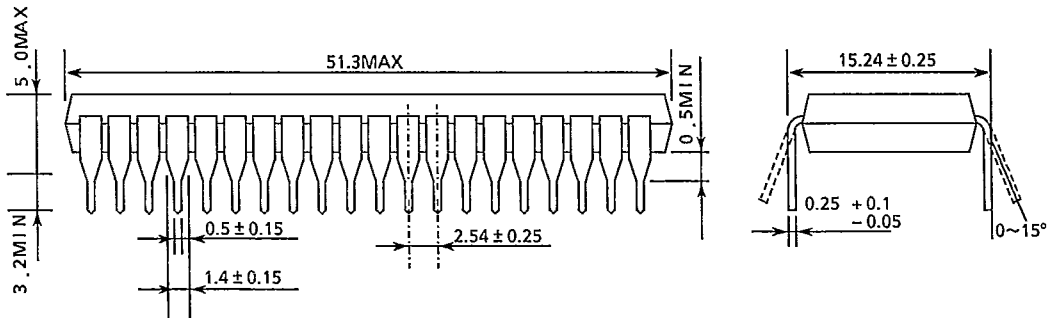
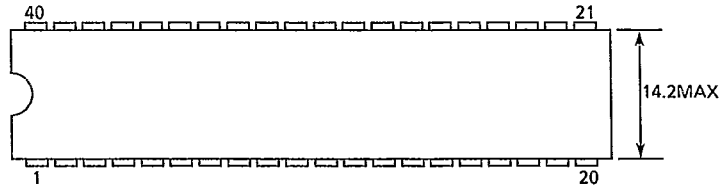

TC8570AP/AF-27

060489

377



