

### Description

- The S71xx prevents the error of system from supply voltage below normal voltage level at the time the power on and instantaneous power off in systems.

### Features

- Current Consumption is Low ( $I_{CCL}=300 \mu A$  Typ.  $I_{CCH}=30 \mu A$  Typ.)
- Resetting Output Minimum Guarantee Voltage is Low (0.8V Typ.)
- Hysteresis Voltage is Provided (50 mV Typ.)

### Applications

- As Control Circuit of Battery-Backed Memory
- As Measure Against Erroneous Operations at Power On-Off
- As Resetting Function for the CPU-Mounted Equipment --- PC, Printer, VTR, Fax, C-TV etc.
- As Measure Against System Runaway at Instantaneous Break of Power Supply etc.

### Ordering Information

Type NO.	Marking	Package Code
S71xxF	S7□□	SOT-89

□□: Detecting Voltage Code

### Outline Dimensions

Unit : mm

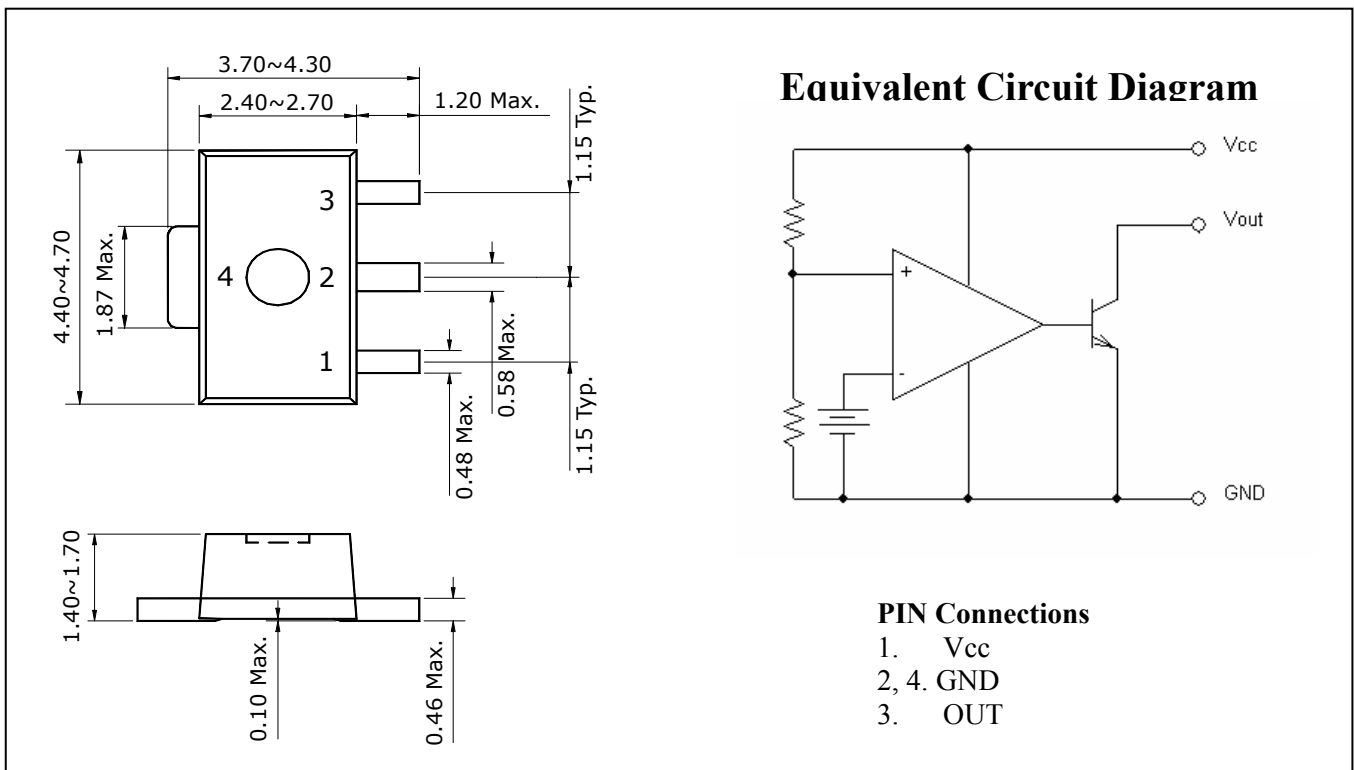

## Maximum ratings

(Ta=25°C)

Characteristic	Symbol	Ratings	Unit
Supply Voltage	V <sub>CC</sub>	-0.3 ~ +15	V
Power Dissipation	P <sub>D</sub>	500	mW
Output Voltage	V <sub>OUT</sub>	-0.3 ~ +15	V
Operating Temperature Range	T <sub>OPR</sub>	-30 ~ +75	°C
Storage Temperature Range	T <sub>STG</sub>	-55 ~ +150	°C

## Electrical Characteristics

(V<sub>CC</sub>=5V, Ta=25°C)

Characteristic	Symbol	Test Circuit	Test Condition	Min.	Typ.	Max.	Unit	
Detecting Voltage	V <sub>S</sub>	1	R <sub>L</sub> =200Ω V <sub>CC</sub> =H→L V <sub>OL</sub> ≤0.4V	S7145F	4.35	4.5	4.65	V
				S7142F	4.05	4.2	4.35	
				S7139F	3.75	3.9	4.05	
				S7136F	3.45	3.6	3.75	
				S7133F	3.15	3.3	3.45	
				S7131F	2.95	3.1	3.25	
				S7129F	2.75	2.9	3.05	
				S7127F	2.55	2.7	2.85	
				S7125F	2.35	2.5	2.65	
S7123F	2.15	2.3	2.45					
Hysteresis Voltage	ΔV <sub>S</sub>	1	R <sub>L</sub> =200Ω, V <sub>CC</sub> =L→H→L	30	50	100	mV	
Temperature Coefficient of Detecting Voltage	V <sub>S</sub> / ΔT	1	R <sub>L</sub> =200Ω, Ta= -30 ~ +75°C	-	±0.01	-	%/°C	
Low Level Output voltage	V <sub>OL</sub>	1	R <sub>L</sub> =200Ω, V <sub>CC</sub> =V <sub>S</sub> Min	-	-	0.4	V	
Leakage Current When OFF	I <sub>LEAK</sub>	1	V <sub>CC</sub> =15V, R <sub>L</sub> =200Ω	-	-	0.1	μA	
Circuit current at ON	I <sub>CCL</sub>	1	V <sub>CC</sub> =V <sub>S</sub> Min	-	300	500	μA	
Circuit current at OFF	I <sub>CCH</sub>	1	V <sub>CC</sub> =V <sub>S</sub> Max +0.1V	-	30	50	μA	
Threshold operating Voltage	V <sub>OPR</sub>	1	R <sub>L</sub> =200Ω, V <sub>OL</sub> ≤0.4V	-	0.8	1.6	V	
Output Current at ON I	I <sub>OL I</sub>	1	R <sub>L</sub> =0Ω, V <sub>CC</sub> =V <sub>S</sub> Min - 0.05V	20	-	-	mA	
Output Current at ON II	I <sub>OL II</sub>	1	R <sub>L</sub> =0Ω, V <sub>CC</sub> =V <sub>S</sub> Min - 0.05V Ta= -30 ~ +75°C	16	-	-	mA	
L→H Transmission delay time	t <sub>PLH</sub>	2	R <sub>L</sub> =1.0 kΩ, C <sub>L</sub> =100 pF	-	15	-	μs	
H→L Transmission delay time	t <sub>PHL</sub>	2	R <sub>L</sub> =1.0 kΩ, C <sub>L</sub> =100 pF	-	10	-	μs	

V<sub>S</sub> : Standard Detection Voltage

**Test Circuit 1**

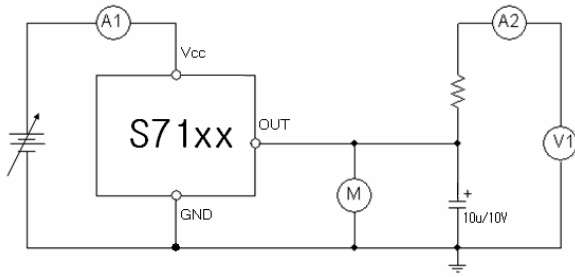

**Test Circuit 2**

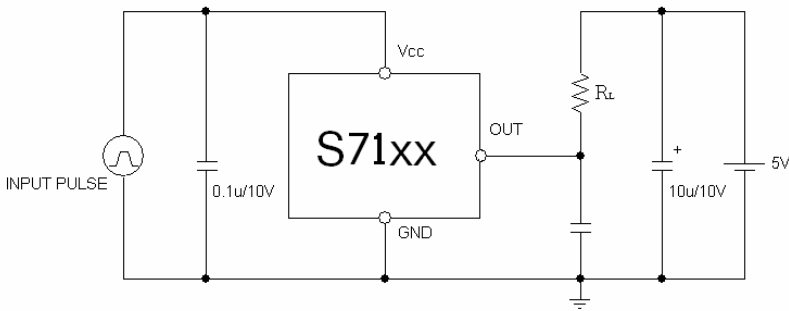

**Application Circuit**

**(1) Battery Low Indicator**

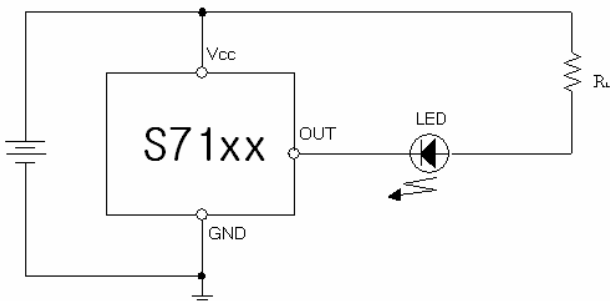

Note 1. : Connecting of LED and R2 obtains a voltage drop indicator.

**(2) Resetting for CPU**

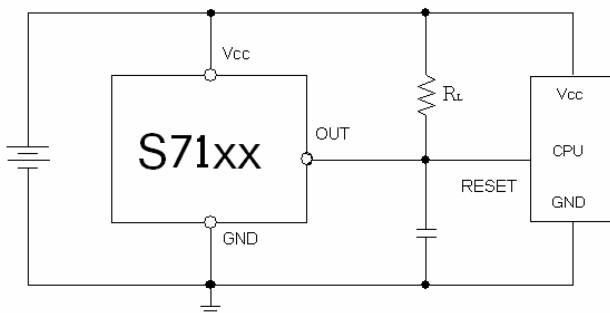

### Electrical Characteristic Curves

Fig. 1  $V_{OUT} - V_{CC}$

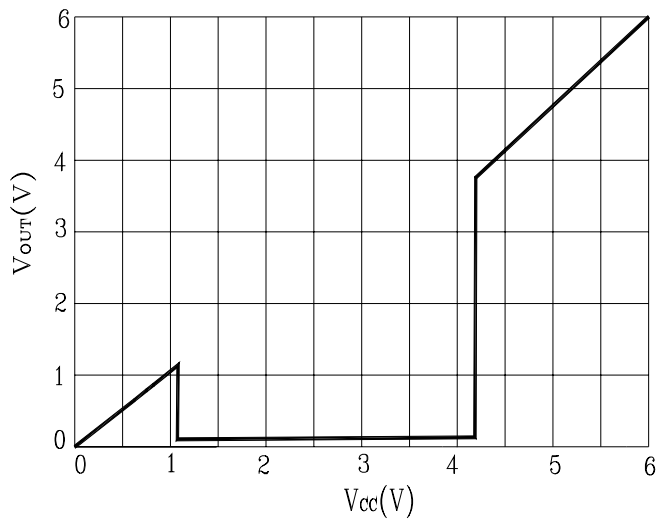

Fig. 2  $I_{CC} - V_{CC}$

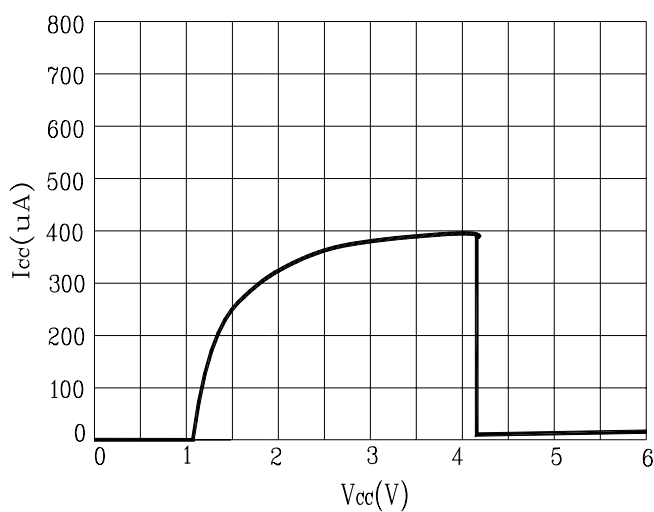

Fig. 3  $I_{CCH} - T_a$

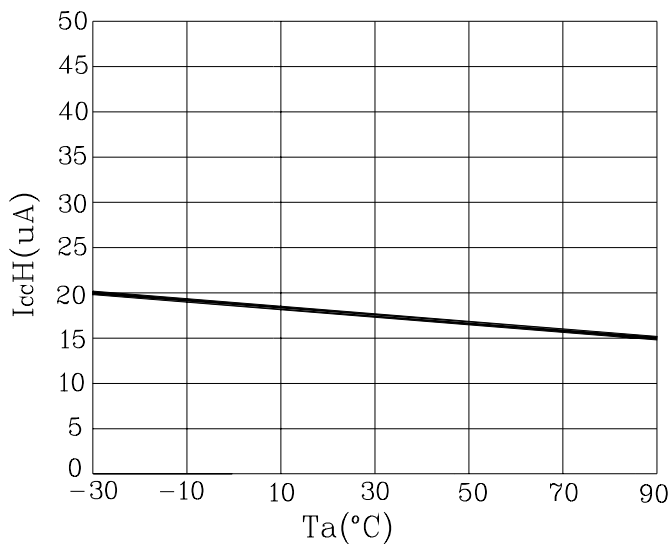
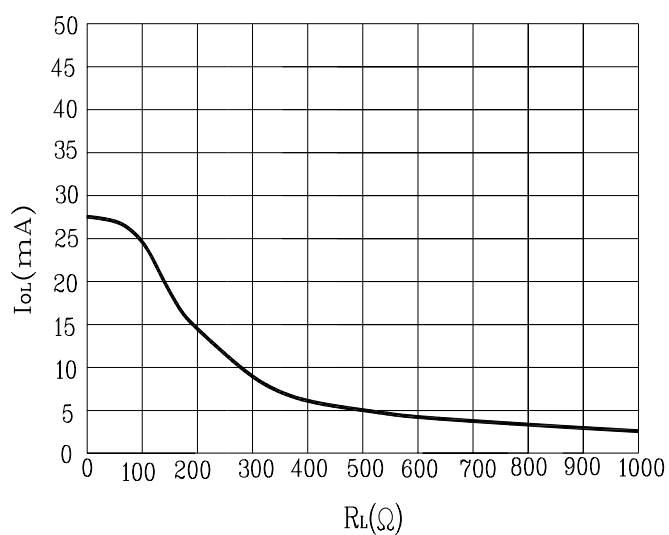

Fig. 4  $I_{OL} - R_L$



**The AUK Corp. products are intended for the use as components in general electronic equipment (Office and communication equipment, measuring equipment, home appliance, etc.).**

**Please make sure that you consult with us before you use these AUK Corp. products in equipments which require high quality and / or reliability, and in equipments which could have major impact to the welfare of human life(atomic energy control, airplane, spaceship, transportation, combustion control, all types of safety device, etc.). AUK Corp. cannot accept liability to any damage which may occur in case these AUK Corp. products were used in the mentioned equipments without prior consultation with AUK Corp..**

**Specifications mentioned in this publication are subject to change without notice.**