

ECN3021

ECN3021 is a single chip three-phase bridge inverter IC which has 6 IGBTs in the circuit. Especially, it is very suitable for controlling the speed of 3-phase DC brushless motors to which converted AC200~230V power supplies are applied. Fig. 1 shows the internal block diagram.

Functions

- * Integrated charge pump circuit
- * Integrated free wheel diodes
- * Integrated PWM circuit
- * Integrated FG circuit
- * Integrated over current protection circuit
- * Integrated rotating direction monitor circuit

Features

- * Speed control for a 3-phase DC brushless motor is available with an external microprocessor.
- * Bottom arm circuits can be operated in 20kHz chopping frequency of PWM.

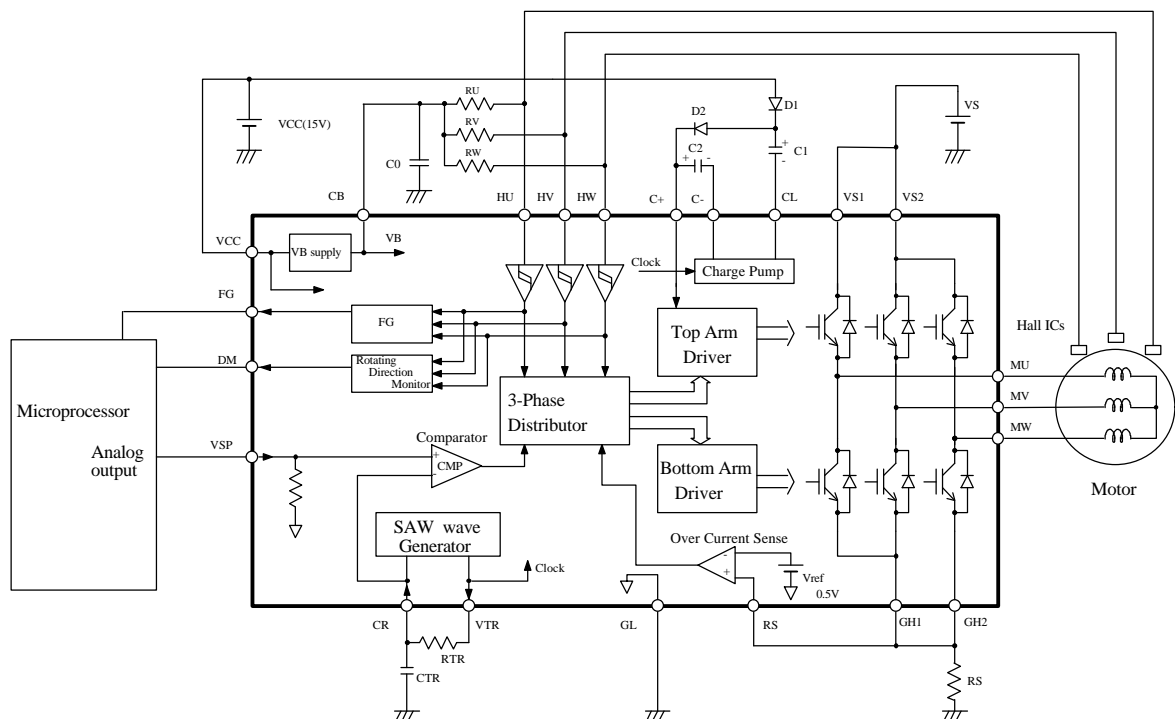

Fig. 1 Block diagram

ECN3021

1. General

- (1) Type ECN3021
- (2) Application 3-phase DC Brushless Motor
- (3) Structure Monolithic IC
- (4) Package SP-23T

2. Maximum Allowable Ratings (Ta=25°C)

No.	Items	Symbols	Terminal	Ratings	Unit	Condition
1	Output Device Breakdown Voltage	VSM	VS1,VS2 MU,MV,MW	500	V	
2	Supply Voltage	VCC	VCC	18	V	
3	Input Voltage	VIN	VSP,RS HU,HV,HW	-0.5 ~ VB+0.5	V	
4	Output Current	IMDC	MU,MV,MW	0.7	A	
5	Peak Output Current	IMP	MU,MV,MW	1.0	A	Note 1
6	Output Current in Start Up and Accelerating	IOM	MU,MV,MW	1.0	A	Note 1
7	Operating Junction Temperature	Tjop		-20 ~ +135	°C	Note 2
8	Storage Temperature	Tstg		-40 ~ +150	°C	

Note 1. Please note that accumulated duty of a period exceeding 0.7A has to be less than 5% of total current flowing period.

Note 2. Thermal Resistance
 $R_{j-c} = 4^{\circ}\text{C/W}$
 $R_{j-a} = 40^{\circ}\text{C/W}$

3. Recommended Operating Conditions

No.	Items	Symbols	Terminal	MIN	TYP	MAX	Unit	Condition
1	Supply Voltage	VS	VS1,2	50	325	370	V	
2		VCC	VCC	13.5	15	16.5	V	

Note. Recommended Safe Operating Area(SOA)

It is recommended that this IC should be used within the SOA as shown below, where IM and VM are the current and the voltage at the terminals connected to motor coils when the phase is changed (turned off).

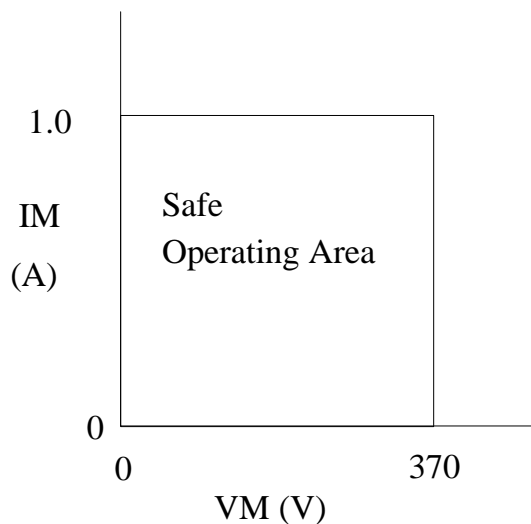

ECN3021

4. Electrical Characteristics (Ta=25°C)

Unless otherwise specified, VCC=15V, VS=325V

Suffix T; Top arm

B; Bottom arm

No.	Items	Symbols	Terminal	MIN	TYP	MAX	Unit	Condition	
1	Standby Current	IS	VS1,2	-	2.5	5.0	mA	VSP=0V	
2		ICC	VCC	-	10	20	mA		
3	Output device FVD	VFT	MU,MV,MW	-	4.0	6.0	V	I=0.35A	
4		VFB	MU,MV,MW	-	4.0	6.0	V	I=0.35A	
5	Turn On	TdONT	MU,MV,MW	-	0.5	3.0	μs	I=0.35A Resistance Load	
6	Delay Time	TdONB	MU,MV,MW	-	0.5	3.0	μs		
7	Turn Off	TdOFFT	MU,MV,MW	-	3.0	6.0	μs		
8	Delay Time	TdOFFB	MU,MV,MW	-	1.0	3.0	μs		
9	Free Wheel	VFDT	MU,MV,MW	-	4.0	6.0	V	I=0.35A	
10	Diode FVD	VFDB	MU,MV,MW	-	4.0	6.0	V		
11	Output Resistance	RVTR	VTR	-	200	400	Ω		
12	H or L Level of	VSAWH	CR	4.9	5.4	6.1	V	Note 2	
13	SAW wave	VSAWL	CR	1.7	2.1	2.5	V		
14	Amplitude of SAW wave	VSAWW	CR	2.8	3.3	3.8	V	Note 3	
15	Reference Voltage	Vref	RS	0.45	0.5	0.55	V		
16	Hall signal	VIH	HU,HV,HW	3.5	-	-	V		
17	Input Voltage	VIL	HU,HV,HW	-	-	1.5	V		
18	Hall signal Input Current	IIL	HU,HV,HW	-100	-	-	μA	HU,HV,HW=0V Note 1 Pull Up Resistance	
19	VSP Input Current	IVSPH	VSP	-	-	100	μA	VSP=5.0V Note 1 Pull Down Resistance	
20	VB Output Voltage	VB	CB	6.8	7.5	8.2	V		
21	VB Output Current	IB	CB	25	-	-	mA	delta Vload=0.1V	
22	FG,DM Output Voltage	VOL	FG,DM	-	1.0	-	V	IOL=-5mA	Note 4
23	FG,DM Output Resistance	ROL	FG,DM	-	200	400	Ω		
24	LVSD Output Voltage	LVSDON	Vcc,MU,	10.0	11.5	12.9	V	Note.5	
25	LVSD recover Voltage	LVSDOFF	MV,MW	10.1	12.0	13.0	V		
26	LVSD reset hysteresis	Vrh		0.1	0.5	0.9	V		

Note 1. Pull Up Resistance and Pull Down Resistance are typically 200 kΩ.

Note 2. Please see Note 2 in item 6 for determining the frequency of SAW wave.

Note 3. The amplitude of SAW(VSAWW) is determined by the following equation,

$$VSAWW = VSAWH - VSAWL \quad (V)$$

Note 4. The equivalent circuit around FG and DM terminal is shown in Fig. 2

Note 5. LVSD: Low Voltage Shut Down

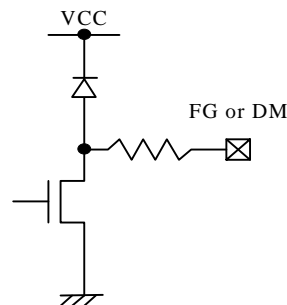

Fig.2 Equivalent circuit around FG or DM

ECN3021

5. Function

5.1 Truth Table

Input			MU		MV		MW	
HU	HV	HW	Top	Bottom	Top	Bottom	Top	Bottom
H	L	H	OFF	ON	ON	OFF	OFF	OFF
H	L	L	OFF	ON	OFF	OFF	ON	OFF
H	H	L	OFF	OFF	OFF	ON	ON	OFF
L	H	L	ON	OFF	OFF	ON	OFF	OFF
L	H	H	ON	OFF	OFF	OFF	OFF	ON
L	L	H	OFF	OFF	ON	OFF	OFF	ON
L	L	L	OFF	OFF	OFF	OFF	OFF	OFF
H	H	H	OFF	OFF	OFF	OFF	OFF	OFF

5.2 Timing Chart

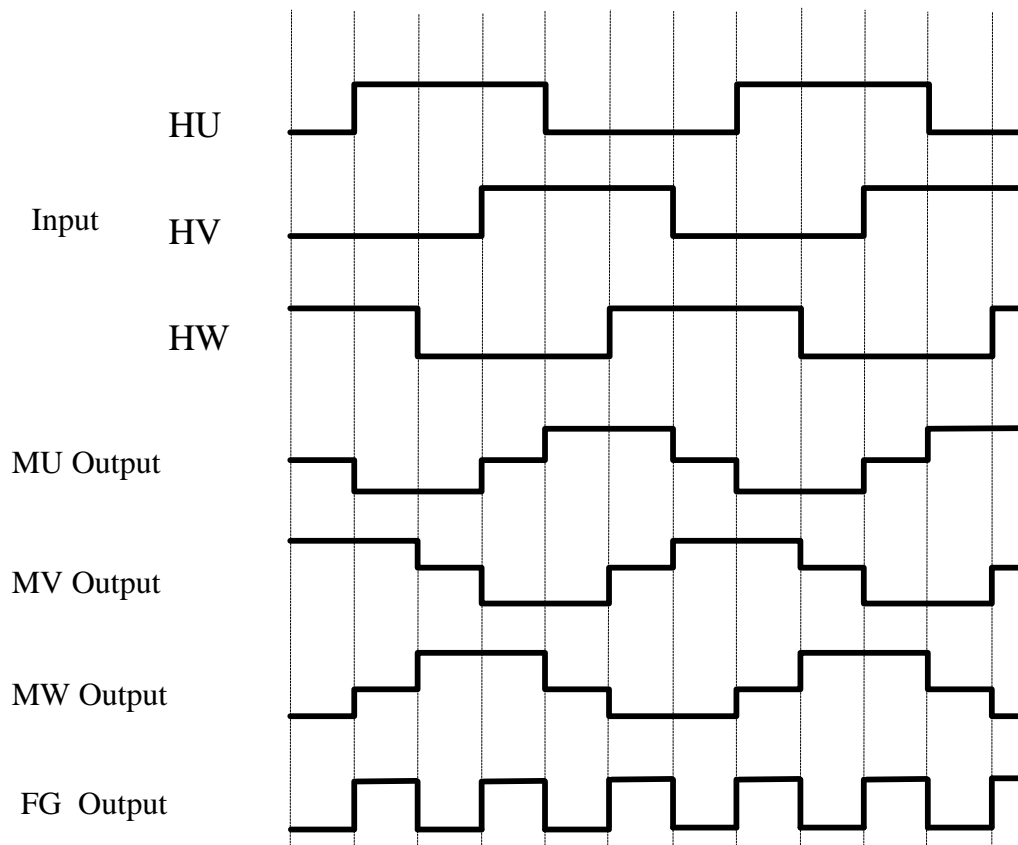

ECN3021

5.3 PWM Operation

The PWM signal is produced by comparing the input voltage at VSP terminal with the voltage from the internal SAW wave. The duty of the PWM signal can be changed by the triangular wave amplitude level, from the minimum point of VSAWL to the maximum point of VSAWH, and when the level is under VSAWL, the duty becomes 0%, and when the level is over VSAWH, the duty becomes 100%. In addition, chopping with the PWM signal is operated in the bottom arm circuit.

5.4 Over Current Limiting Operation

This IC detects over current by checking the voltage drop at the external resistance RS. When the input voltage at RS terminal exceeds the internal reference voltage(Vref), this IC turns off the output of the bottom arm circuit. After over current detection, reset operation is done at every period of the inner clock signal (VTR terminal).

5.5 Rotating Direction Sense Operation

The rotation direction of the motor is detected by the signal at DM terminal. Table 1 shows the output signal for the rotation direction.

Table 1. Output signal for the rotation direction

Rotating Direction	Output (DM terminal)
U-V-W	L
U-W-V	H

5.6 Vcc under voltage Detection

When Vcc supply voltage becomes below LVSDON(11.5V typ), all of the IGBTs shut off. This condition is recovered when Vcc supply voltage becomes greater than LVSDOFF(12.0V typ).

ECN3021

6. Standard Application

Component	Recommended Value	Usage	Remark
C0	More than 0.22 μ F	for inner power supply(VB).	stress voltage is VB
C1,C2	0.5 μ F \pm 20%	for charge pump	stress voltage is VCC
D1,D2	Hitachi DFG1C6(glass mold) Hitachi DFM1F6(resin mold) or equivalent parts	for charge pump	600V/1.0A trr \leq 100ns
Rs	Note 1.	for current limiting	
CTR	1800 pF \pm 5%	for PWM	Note 2.
RTR	22 k Ω \pm 5%	for PWM	Note 2.

Note 1. Start up current is limited by the following equation.

$$IO = V_{ref} / R_s \quad (A)$$

Note 2. PWM frequency is approximately determined by the following equation.

$$f_{PWM} = -1 / (2C * R * \ln(1 - 3.5/5.5)) \quad ; \ln \text{ is natural logarithm}$$

$$= 0.494 / (C * R) \quad (Hz)$$

Note 3. It is recommended that RU,RV,RW should be 5.6 k Ω \pm 5%.

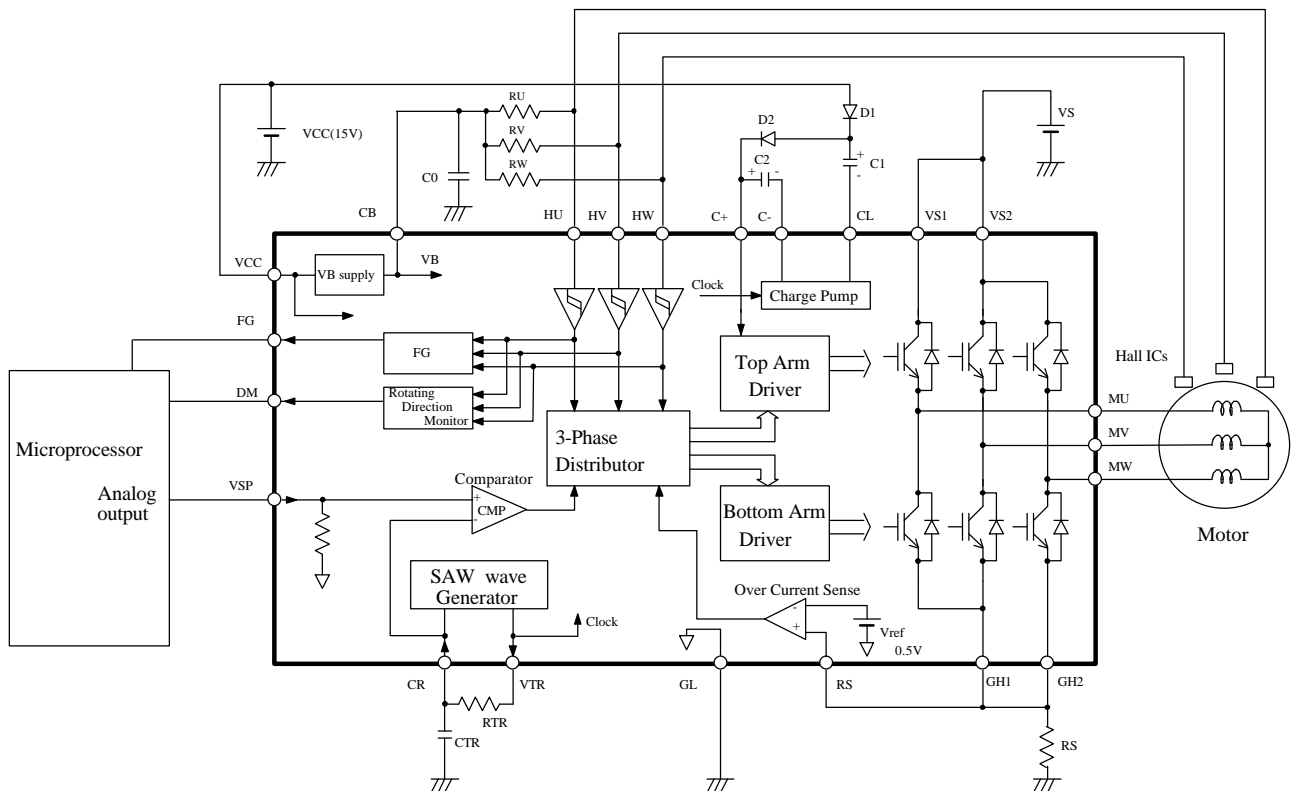

Fig 3. Block diagram and external elements

ECN3021

7. Terminal

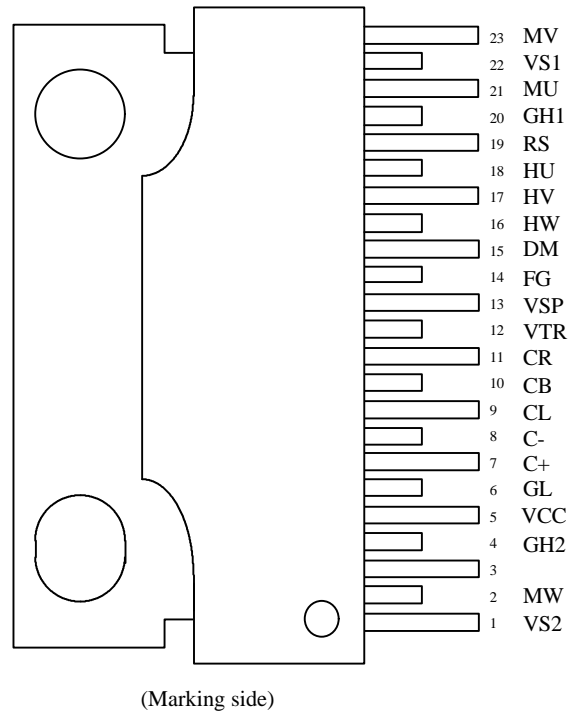
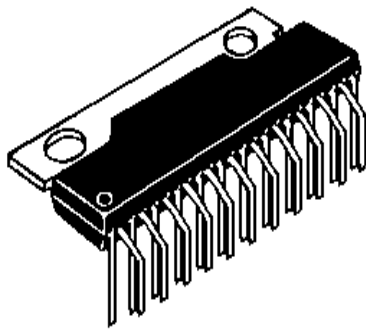
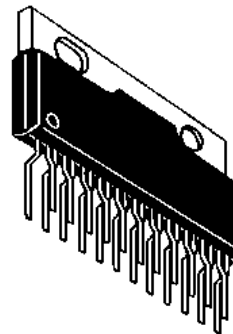

Fig.4 Pin Connection

8. Package Outline



ECN3021SP



ECN3021SPV

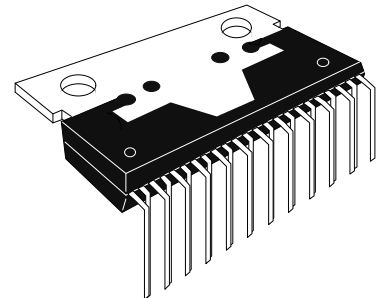

ECN3021SPR

ECN3021

8. Package Dimensions (1) ECN3021SP

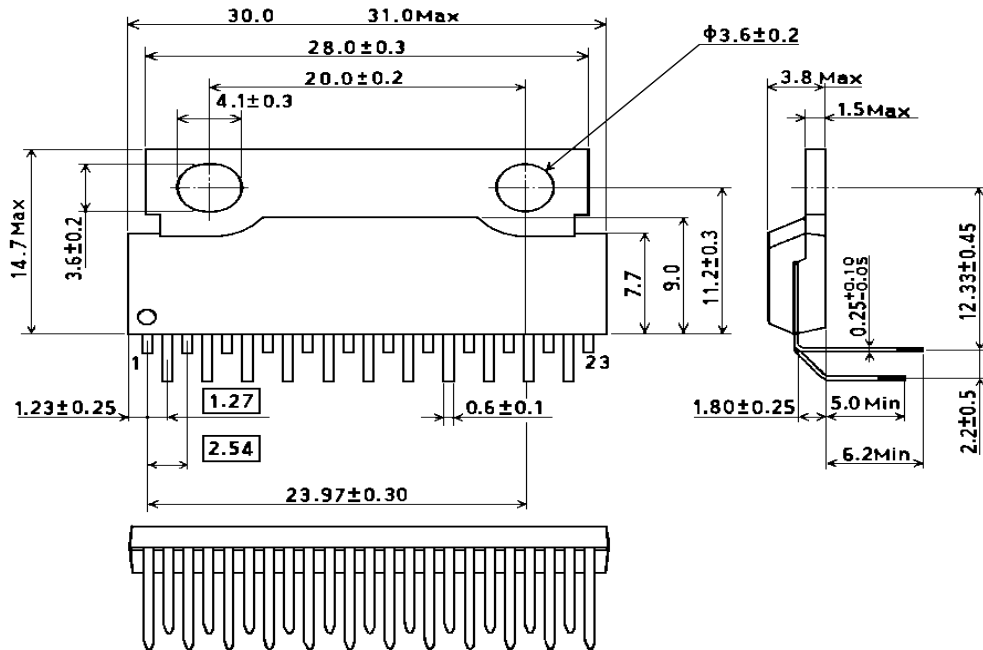

(2) ECN3021SPV

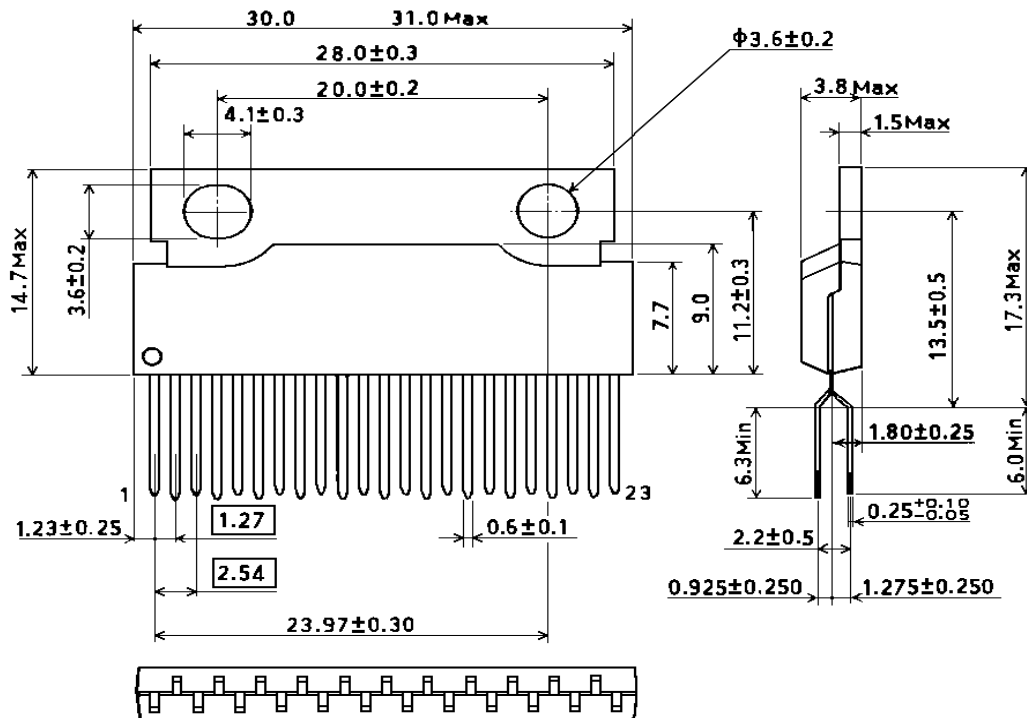

ECN3021

(3) ECN3021SPR

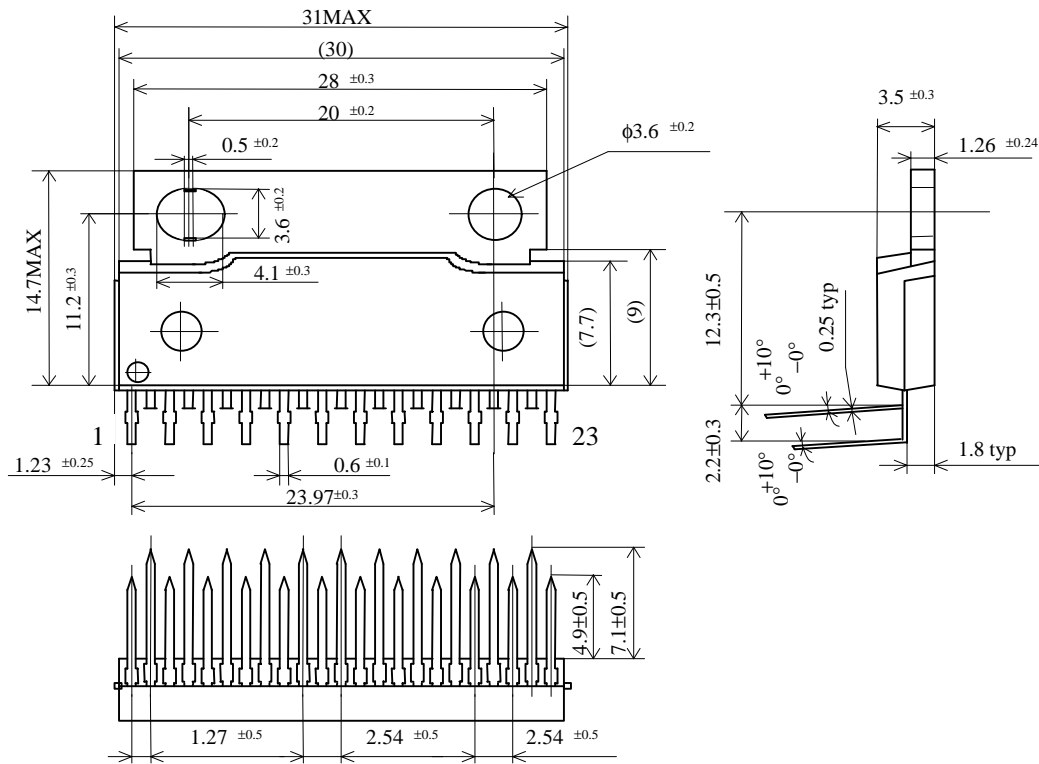

HITACHI POWER SEMICONDUCTORS

Notices

- 1.The information given herein, including the specifications and dimensions, is subject to change without prior notice to improve product characteristics. Before ordering, purchasers are advised to contact Hitachi sales department for the latest version of this data sheets.
- 2.Please be sure to read "Precautions for Safe Use and Notices" in the individual brochure before use.
- 3.In cases where extremely high reliability is required(such as use in nuclear power control, aerospace and aviation, traffic equipment, life-support-related medical equipment, fuel control equipment and various kinds of safety equipment), safety should be ensured by using semiconductor devices that feature assured safety or by means of users' fail-safe precautions or other arrangement. Or consult Hitachi's sales department staff.
- 4.In no event shall Hitachi be liable for any damages that may result from an accident or any other cause during operation of the user's units according to this data sheets. Hitachi assumes no responsibility for any intellectual property claims or any other problems that may result from applications of information, products or circuits described in this data sheets.
- 5.In no event shall Hitachi be liable for any failure in a semiconductor device or any secondary damage resulting from use at a value exceeding the absolute maximum rating.
- 6.No license is granted by this data sheets under any patents or other rights of any third party or Hitachi, Ltd.
- 7.This data sheets may not be reproduced or duplicated, in any form, in whole or in part , without the expressed written permission of Hitachi, Ltd.
- 8.The products (technologies) described in this data sheets are not to be provided to any party whose purpose in their application will hinder maintenance of international peace and safety not are they to be applied to that purpose by their direct purchasers or any third party. When exporting these products (technologies), the necessary procedures are to be taken in accordance with related laws and regulations.

-
- For inquiries relating to the products, please contact nearest overseas representatives which is located "Inquiry" portion on the top page of a home page.
-

Hitachi power semiconductor home page address <http://www.hitachi.co.jp/pse>