

RT9233 Data Sheet



4-Bit Programmable Synchronous PWM Buck Converter Controller

General Description

The RT9233 is a high efficient synchronous switching regulator for modern CPU application. The output is controlled by a 4-bit DAC programmed from 1.3V to 2.05V in 0.05V steps. The 1.265V reference is available for external linear regulator.

The switching controller drives two N-MOSFETs at 200KHz frequency and provides an optimal solution for size, efficiency, and cost in any application circuits. The controller also offers integrated functions including output enable, internal digital-count soft start, over-voltage, and current-limiting protection in one chip.

Features

- High Efficient Synchronous N-MOSFET Driver Operating at 200KHz
- 1.3V~2.05V (0.05V steps)
- Enable Input, OVP, and Current-limiting Protection
- Internal Digital-count Soft Start
- Reference Output

Applications

- Pentium® II Microprocessors Power Supplies
- Flexible Motherboards Power Supplies
- Low-voltage Distributed Power Supplies
- Programmable Step-down Power Supplies

Ordering Information

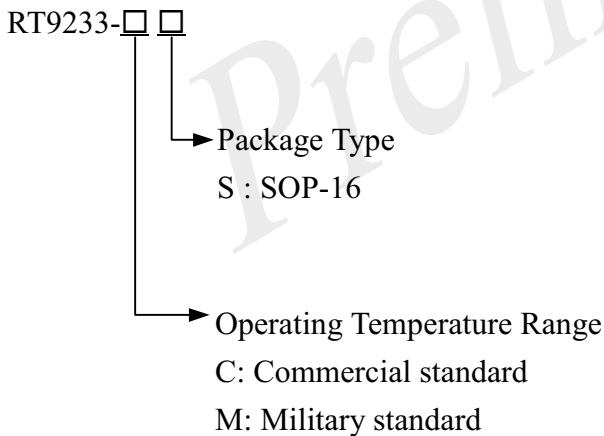

Pin Configurations

Part Number	Pin Configurations
RT9233-CS	

Absolute Maximum Ratings

- VCC to GND (V_{IN}) ----- -0.3 to +5.5V
- PGND to GND ----- $\pm 0.3V$
- BST to GND ----- -0.3 to +14V
- Ambient Temperature Range (T_A) ----- 0 to +70°C
- Junction Temperature Range (T_J) ----- 0 to +125°C
- Storage Temperature Range (T_{STG}) ----- -65 to +150°C
- Lead Temperature (Soldering) 10 seconds (T_L) ----- 300°C
- Thermal Impedance Junction to Ambient (θ_{JA}) ----- 80°C/W
- Thermal Impedance Junction to Case (θ_{JC}) ----- 25°C/W

Electrical Characteristics

VCC = 5V; GND = 0V; PGND = 0V; VSEN = VOUT; $0mV < (V_{CSP} - V_{CSN}) < 60mV$; $T_A = 25^\circ C$

Parameter	Test Conditions	Min	Typ	Max	Units
Switching Section					
Output Voltage	$I_O = 2A$		(1)		
Supply Voltage	VCC	4.3	-	5.5	V
Supply Current		-	2	5	mA
Load Regulation	$I_O = 0.8A$ to 15A	-	1	-	%
Line Regulation	VCC = 4.75V to 5.25V	-	0.5	-	%
Power On Reset Trip Point	VCC Rising	-	4.2	-	V
Current Limit Voltage	$V_{CSP} - V_{CSN}$	65	75	85	mV
Oscillator Frequency		170	200	230	KHz
Oscillator Max Duty Cycle		90	95	-	%
DH Source	$V_{BSTH} - V_{DH} = 1V$	-	3.5	-	Ω
DH Sink	$V_{DH} - V_{PGND} = 1V$	-	3.5	-	Ω
DL Source	$V_{BSTL} - V_{DL} = 3V$	-	2	-	Ω
DL Sink	$V_{DL} - V_{PGND} = 1V$	-	2	-	Ω
OVP Threshold Voltage		-	120	-	%
Reference Voltage	$I_{ref} \leq 100\mu A$	-	1.265	-	V

Note: (1) See output voltage table (on Page 5.)

Function Block Diagram

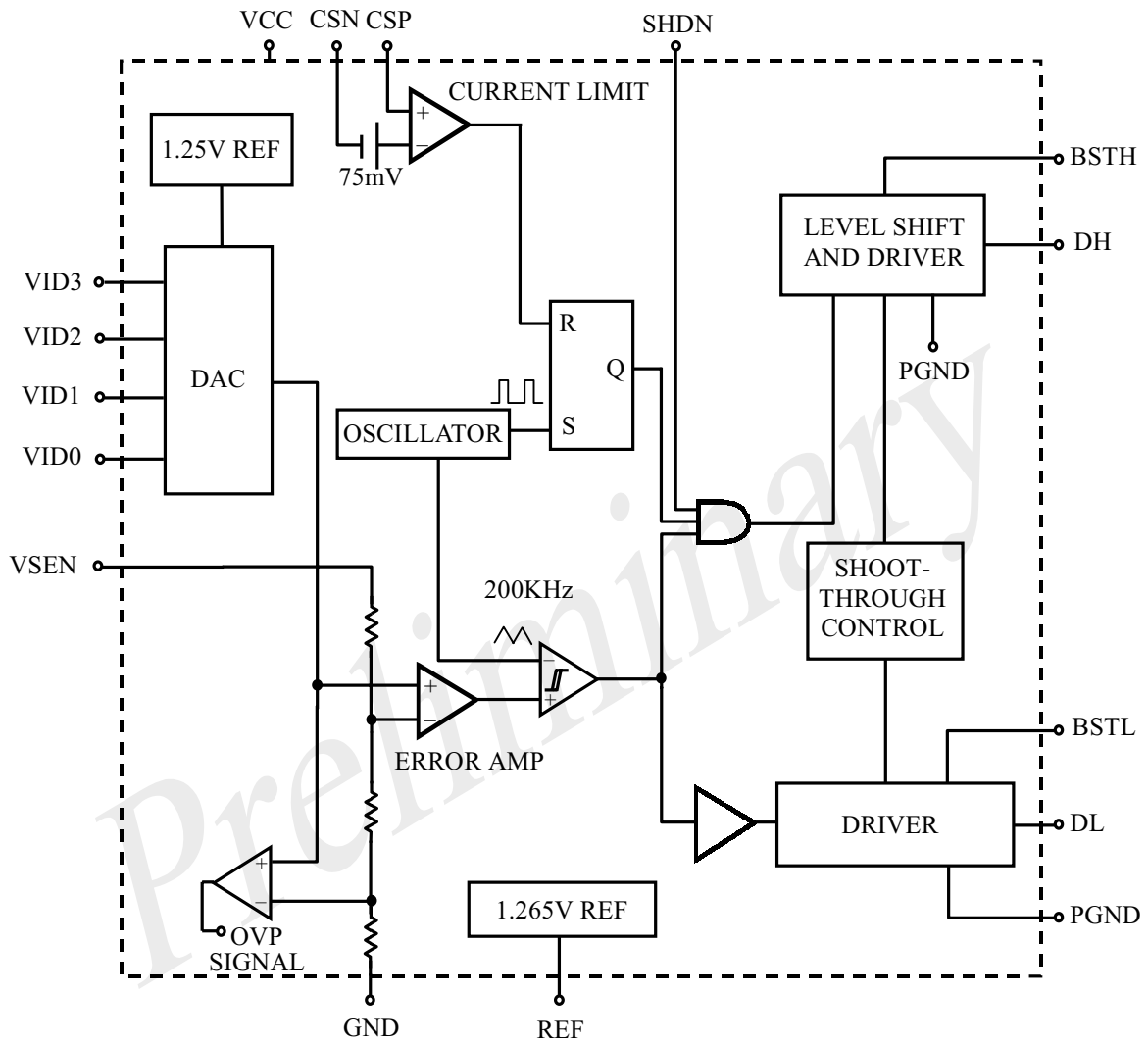

Pin Description

Pin No.	Pin Name	Pin Function
1	GND	Small signal analog and digital ground
2	REF	Buffered reference output
3	VCC	IC power
4	CSN	Current sense input (Negative)
5	CSP	Current sense input (Positive)
6	PGND	Power ground for high side and low side switches
7	DH	High side driver output
8	DL	Low side driver output
9	BSTL	Supply for low side driver
10	BSTH	Supply for high side driver
11	SHDN ⁽¹⁾	Logic low shutdown the converter
12	VSEN	Top end of internal feedback chain
13	VID3 ⁽¹⁾	Programming input(MSB)
14	VID2 ⁽¹⁾	Programming input
15	VID1 ⁽¹⁾	Programming input
16	VID0 ⁽¹⁾	Programming input (LSB)

Note: (1) All logic level inputs and outputs are TTL compatible.

Output Voltage

Test Item	Conditions	VID 3210	Min	Typ	Max	Units
Output Voltage	$I_o = 2A$ in application circuit	1111	1.274	1.300	1.326	V
		1110	1.323	1.350	1.377	
		1101	1.372	1.400	1.428	
		1100	1.421	1.450	1.479	
		1011	1.478	1.500	1.523	
		1010	1.527	1.550	1.573	
		1001	1.576	1.600	1.624	
		1000	1.625	1.650	1.675	
		0111	1.675	1.700	1.726	
		0110	1.724	1.750	1.776	
		0101	1.773	1.800	1.827	
		0100	1.822	1.850	1.878	
		0011	1.872	1.900	1.929	
		0010	1.921	1.950	1.979	
		0001	1.970	2.000	2.030	
0000	2.019	2.050	2.081			

Typical Application Circuit

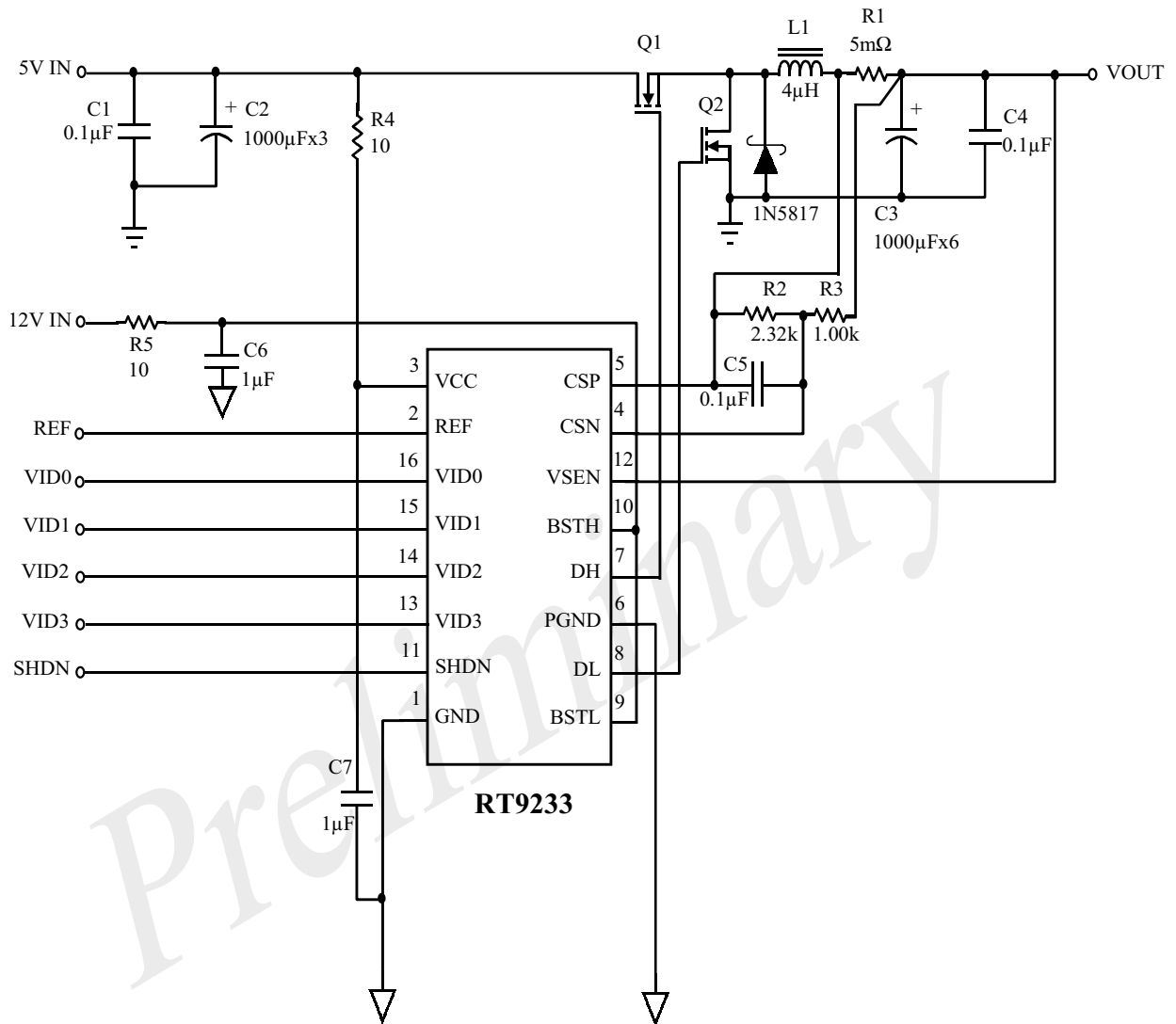

Package Information

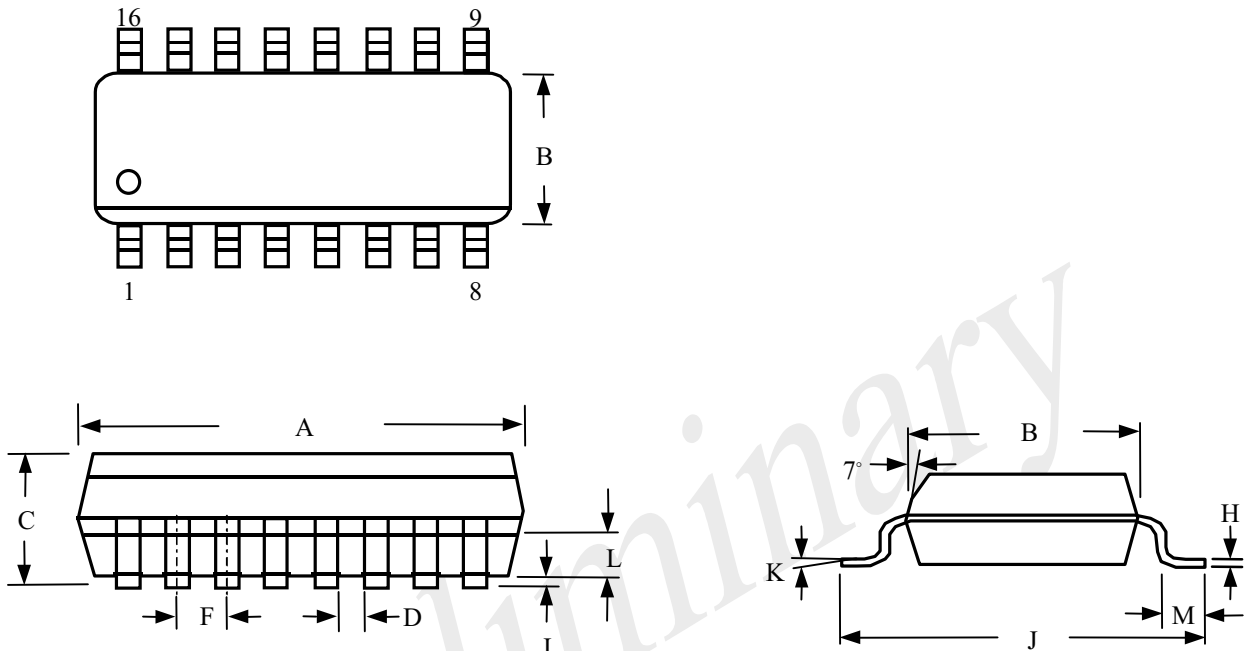

Symbol	Dimensions In Inch			Dimensions In Millimeter		
	Min	Norm	Max	Min	Norm	Max
A	0.386	0.390	0.394	9.800	9.900	10.000
B	0.150	0.154	0.158	3.800	3.900	4.000
C	0.058	0.063	0.068	1.470	1.600	1.730
D	0.015	0.016	0.017	0.390	0.400	0.410
F	-	0.05	-	-	1.270	-
H	0.008	0.009	0.010	0.200	0.230	0.260
I	0.003	0.006	0.009	0.080	0.160	0.240
J	0.234	0.236	0.238	5.95	6.000	6.050
K	-	5°	-	-	5°	-
L	0.023	0.024	0.025	0.600	0.610	0.620
M	0.020	0.028	0.035	0.500	0.700	0.900