



rev 1.0

General Purpose EMI Reduction IC

Features

- Provides up to 15 dB of EMI suppression
- FCC approved method of EMI attenuation
- Generates a 1X, 2X, and 4X low EMI spread spectrum clock of the input frequency
- Input frequency range from 3 to 78 MHz
- External loop filter for spread % adjustment
- Spreading ranges from $\pm 0.25\%$ to $\pm 5.0\%$
- Ultra low cycle-to-cycle jitter
- Zero-cycle slip
- 3.3V operating voltage range
- 10 mA output drives
- TTL or CMOS compatible outputs
- Ultra-low power CMOS design
- Available in 8 pin SOIC and TSSOP
- Available for industrial and automotive temperature ranges.

Product Description

The P278xx is a versatile spread spectrum frequency modulator designed specifically for digital camera and other digital video and imaging applications. The P278xx reduces electromagnetic interference (EMI) at the clock source, which provides system wide reduction of EMI of all clock

dependent signals. The P278xx allows significant system cost savings by reducing the number of circuit board layers and shielding that are traditionally required to pass EMI regulations.

The P278xx uses the most efficient and optimized modulation profile approved by the FCC.

The P278xx modulates the output of a single PLL in order to “spread” the bandwidth of a synthesized clock and, more importantly, decreases the peak amplitudes of its harmonics. This results in significantly lower system EMI compared to the typical narrow band signal produced by oscillators and most frequency generators. Lowering EMI by increasing a signal’s bandwidth is called spread spectrum clock generation.

Applications

The P278xx is targeted towards MFP, xDSL, fax modem, set-top box, USB controller, DSC, and embedded systems.

Block Diagram

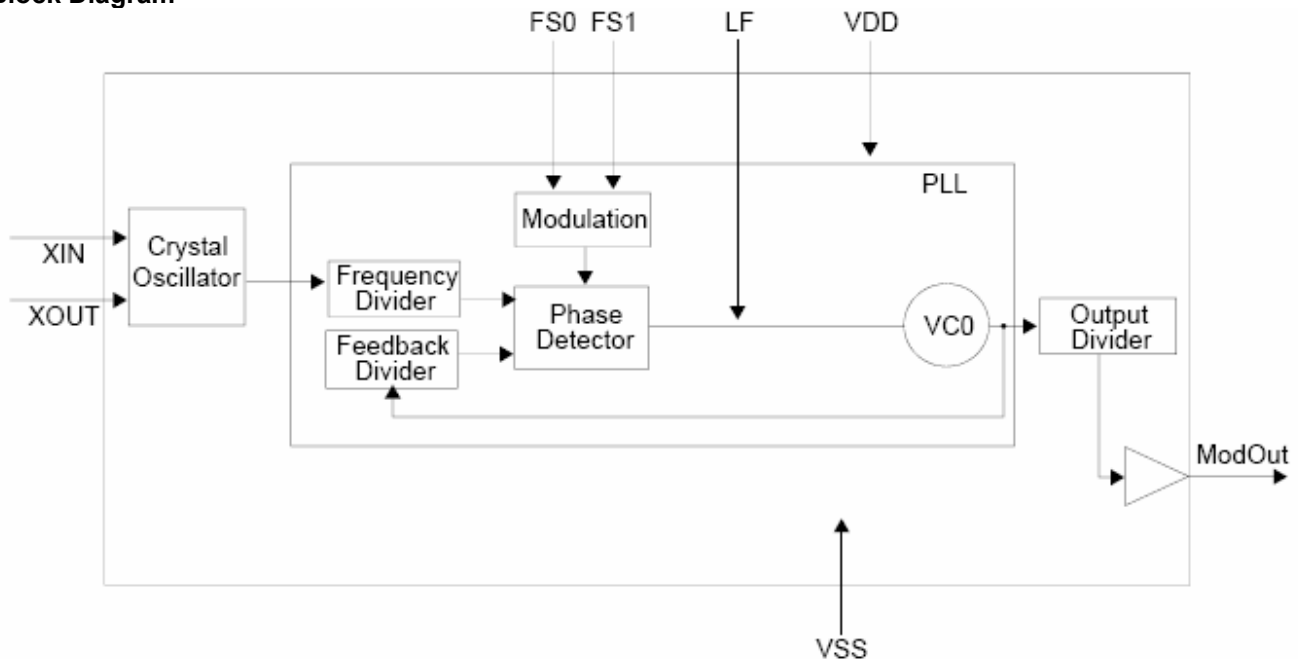



rev 1.0

Pin Configuration

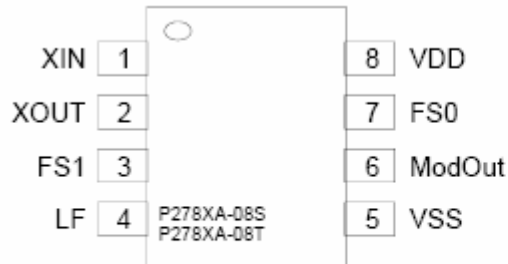

Standard pin configuration offered in both 8 SOIC and TSSOP packages.

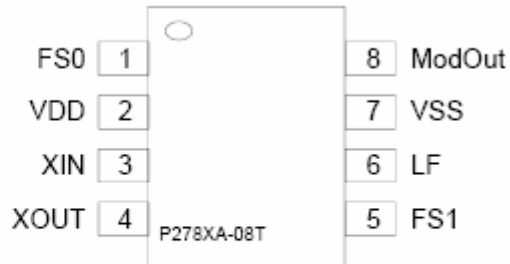

Alternative pin configuration offered in only 8 TSSOP package

Pin Description (P278XA)

Pin#	Pin Name	Type	Description
1	XIN/CLKIN	I	Connect to crystal or clock input.
2	XOUT	I	Crystal output
3	FS1	I	Digital logic input used to select input frequency range (see the Input Frequency Selection Table). This pin has an internal pull-up resistor.
4	LF	I	External Loop Filter for the PLL. By changing the value of the CRC circuit, the percentage spread can be adjusted accordingly. See the Loop Filter Selection Table for detail value.
5	VSS	I	Ground Connection. Connect to system ground.
6	ModOUT	O	Spread Spectrum Clock Output.
7	FS0	I	Digital logic input used to select input frequency range (see the Input Frequency Selection Table). This pin has an internal pull-up resistor.
8	VDD	P	Connect to +3.3 V

Input Frequency Selection Table

FS1	FS0	Input (MHz)	Output Frequency Scaling (MHz)			Modulation Rate (KHz)
			P2781X	P2782X	P2784X	
0	0	3 to 9	3 to 9	6 to 18	12 to 36	Fin / 128
0	1	10 to 19	10 to 19	20 to 38	40 to 76	Fin / 256
1	0	20 to 38	20 to 38	40 to 76	80 to 152	Fin / 512
1	1	39 to 78	39 to 78	78 to 156	156 to 312	Fin / 1024



rev 1.0

Loop Filter Selection Table VDD 3.3V

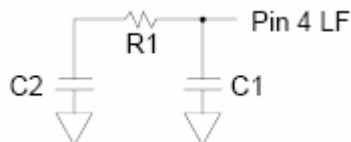

Contact Alliance for loop values that are not listed in the table and for component selection values for industrial and automotive temperatures.

Input MHz	FS1	FS0	BW = ±0.50% ¹			BW = ±0.75% ¹			BW = ±1.00% ¹			BW = ±1.25% ¹		
			C1 (pF)	C2 (pF)	R1 (ohm)	C1 (pF)	C2 (pF)	R1 (ohm)	C1 (pF)	C2 (pF)	R1 (ohm)	C1 (pF)	C2 (pF)	R1 (ohm)
3	0	0	270	330,000	220	270	330,000	300	270	100,000	390	560	100,000	510
4	0	0	270	100,000	270	270	100,000	390	270	100,000	560	560	100,000	680
5	0	0	270	100,000	390	270	100,000	560	270	100,000	750	560	100,000	910
6	0	0	270	100,000	510	270	100,000	750	270	10,000	1,000	680	6,800	1,200
7	0	0	270	100,000	620	270	100,000	1,000	270	5,600	1,200	330	3,300	1,200
8	0	0	270	100,000	820	270	100,000	1,200	270	12,000	2,200	680	6,800	2,200
9	0	0	270	100,000	1,000	270	100,000	1,500	270	5,600	2,200	270	2,700	2,200
10	0	1	270	100,000	330	270	100,000	510	270	100,000	750	560	100,000	910
11	0	1	270	100,000	390	270	100,000	560	270	100,000	866(1%)	560	100,000	1,100
12	0	1	270	100,000	510	270	100,000	750	270	10,000	1,000	680	6,800	1,200
13	0	1	270	100,000	560	270	100,000	820	270	12,000	1,200	470	4,700	1,200
14	0	1	270	100,000	620	270	100,000	1,000	270	5,600	1,200	330	3,300	1,200
15	0	1	270	100,000	750	270	100,000	1,100	270	3,900	1,200	330	3,300	1,500
16	0	1	270	100,000	820	270	100,000	1,200	270	12,000	2,200	680	6,800	2,200
17	0	1	270	100,000	910	270	100,000	1,300	270	10,000	2,200	390	3,900	2,200
18	0	1	270	100,000	1,000	270	100,000	1,500	270	5,600	2,200	270	2,700	2,200
19	0	1	270	100,000	1,200	270	100,000	1,600	270	3,300	2,200	270	2,700	2,700
20	0	0	270	100,000	330	270	100,000	560	270	100,000	750	560	100,000	910
21-22	1	0	270	100,000	390	270	100,000	620	270	100,000	866 (1%)	560	100,000	1,100
23-24	1	0	270	100,000	510	270	100,000	750	270	10,000	1,000	680	6,800	1,200
25-26	1	0	270	100,000	560	270	100,000	820	270	12,000	1,200	470	4,700	1,200
27-28	1	0	270	100,000	620	270	100,000	1,000	270	6,800	1,200	330	3,300	1,200
29-30	1	0	270	100,000	750	270	100,000	1,100	270	3,900	1,200	330	3,300	1,500
31-32	1	0	270	100,000	820	270	100,000	1,200	270	12,000	2,200	680	6,800	2,200
33-34	1	0	270	100,000	910	270	100,000	1,300	270	10,000	2,200	390	3,900	2,200
35-36	1	0	270	100,000	1,000	270	100,000	1,500	270	5,600	2,200	270	2,700	2,200
37-38	1	0	270	100,000	1,200	270	100,000	1,600	270	3,300	2,200	270	2,700	2,700
39-42	1	1	270	100,000	330	270	100,000	560	270	100,000	750	560	100,000	910
43-46	1	1	270	100,000	390	270	100,000	620	270	100,000	866 (1%)	560	100,000	1,100
47-50	1	1	270	100,000	510	270	100,000	750	270	10,000	1,000	680	6,800	1,200
51-54	1	1	270	100,000	560	270	100,000	820	270	12,000	1,200	470	4,700	1,200
55-58	1	1	270	100,000	620	270	100,000	1,000	270	6,800	1,200	330	3,300	1,200
59-62	1	1	270	100,000	750	270	100,000	1,100	270	3,900	1,200	330	3,300	1,500
63-66	1	1	270	100,000	820	270	100,000	1,200	270	12,000	2,200	680	6,800	2,200
67-70	1	1	270	100,000	910	270	100,000	1,300	270	8,200	2,200	390	3,900	2,200
71-74	1	1	270	100,000	1,000	270	100,000	1,600	270	5,600	2,200	270	2,700	2,200
75-78	1	1	270	100,000	1,200	270	100,000	1,800	270	3,300	2,200	270	2,700	2,700

¹ The BW value is representative of typical conditions



rev 1.0

Spread Spectrum Selection

The P278xA performs Zero Cycle Slip when set at low percentage spreading. This allows no occurrence of system timing error. The optimal setting should minimize system EMI to the fullest without affecting system performance. The spreading is described as a percentage deviation of the center frequency. (Note: the center frequency is the frequency of the external reference input on CLKIN, Pin 1.)

The P2781A is designed for PC peripheral, networking, notebook PC, and LCD monitor applications. It is optimized for operation between 3 to 78 MHz range. In the following application schematic example, the P2781A spread percentage selection is determined by the external LF value specified in the Loop Filter Selection Table. The Input Frequency Selection Table specifies the input frequency range. The external LF allows the user to fine tune the spread percentage to optimize the EMI reduction benefits of the spread spectrum.

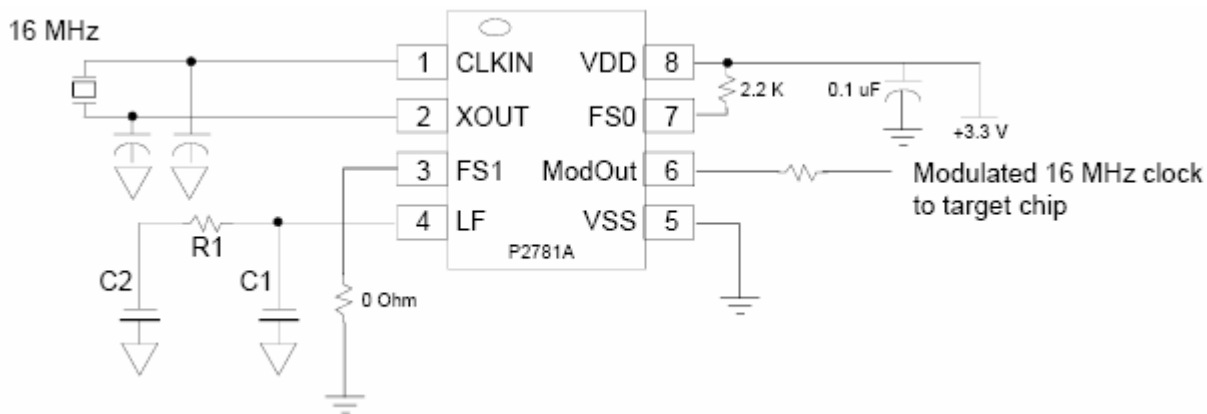

Note: Both logic input pins FS1 and FS0 have to be connected to either VDD or VSS. Do not leave them floating.



rev 1.0

Absolute Maximum Ratings

Symbol	Parameter	Rating	Unit
V_{DD}, V_{IN}	Voltage on any pin with respect to GND	-0.5 to + 7.0	V
T_{STG}	Storage temperature	-65 to +125	°C
T_A	Operating temperature	0 to +70	°C

DC Electrical Characteristics

Symbol	Parameter	Min	Typ	Max	Unit
V_{IL}	Input low voltage	GND – 0.3	–	0.8	V
V_{IH}	Input high voltage	2.0	–	$V_{DD} + 0.3$	V
I_{IL}	Input low current (internal input pull-up resistor on FS0 and FS1)	–	60	–	μA
I_{IH}	Input high current (internal input pull-up resistor on FS0 and FS1)	–	0	–	μA
I_{XOL}	XOUT output low current	–	10	–	mA
I_{XOH}	XOUT output high current	–	10	–	mA
V_{OL}	Output low voltage ($V_{DD} = 3.3$ V, $I_{OL} = 20$ mA)	–	–	0.4	V
V_{OH}	Output high voltage ($V_{DD} = 3.3$ V, $I_{OH} = 20$ mA)	2.5	–	–	V
I_{DD}	Static supply current	–	3	–	mA
I_{CC}	Typical dynamic supply current (25 pF scope probe loading)	5.2 at 3 MHz	–	21.2 at 82 MHz	mA
V_{DD}	Operating voltage	3.0	3.3	3.6	V

AC Electrical Characteristics

Symbol	Parameter	Min	Typ	Max	Unit
f_{IN}	Input frequency: P278XX	3		78	MHz
f_{OUT}	Output frequency: P2781X P2782X P2784X	3 6 12		78 156 312	MHz
t_{LH} P278XX	Output rise time (measured at 0.8 V to 2.0 V, 25 pF scope probe loading)		1		ns
t_{HL} P278XX	Output fall time (measured at 2.0 V to 0.8 V, 25 pF scope probe loading)		1		ns
t_{JC} P2781X	Jitter (cycle to cycle, $\pm 6\sigma$, 1000 sweeps, $\pm 0.5\%$ spread, I/O frequency = 16 MHz)		± 250		ps
t_D P2781X	Output duty cycle deviation (error from 50% duty cycle, 25 pF scope probe loading)	± 1 at 3 MHz		± 2 at 82 MHz	%
ΔF P278XX	Frequency deviation tolerance from BW% stated in the Loop Filter Selection Table	-20	0	+20	%



rev 1.0

Package Information

Mechanical Package Outline 8-Pin SOIC

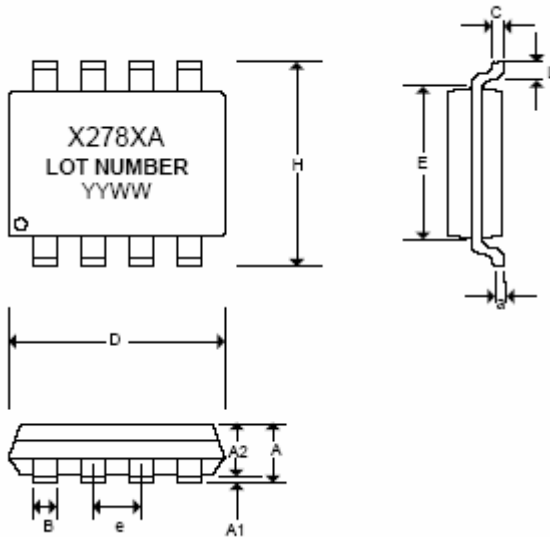

Symbol	Dimensions in inches			Dimensions in millimeters		
	Min	Nor	Max	Min	Nor	Max
A	0.057	0.064	0.071	1.45	1.63	1.80
A1	0.004	0.007	0.010	0.10	0.18	0.25
A2	0.053	0.061	0.069	1.35	1.55	1.75
B	0.012	0.016	0.020	0.31	0.41	0.51
C	0.004	0.006	0.01	0.10	0.15	0.25
D	0.186	0.194	0.202	4.72	4.92	5.12
E	0.148	0.156	0.164	3.75	3.95	4.15
e	0.050 BSC			1.27 BSC		
H	0.224	0.236	0.248	5.70	6.00	6.30
L	0.012	0.020	0.028	0.30	0.50	0.70
a	0°	5°	8°	0°	5°	8°

Note: Controlling dimensions are millimeters
SOIC - 0.074 grams unit weight



rev 1.0

Mechanical Package Outline 8-Pin TSSOP

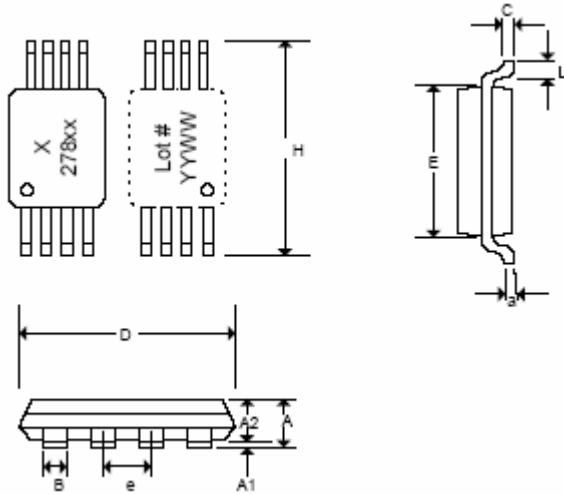

Symbol	Dimensions in inches			Dimensions in millimeters		
	Min	Nor	Max	Min	Nor	Max
A			0.047			1.10
A1	0.002		0.006	0.05		0.15
A2	0.031	0.039	0.041	0.80	1.00	1.05
B	0.007		0.012	0.19		0.30
C	0.004		0.008	0.09		0.20
D	0.114	0.118	0.122	2.90	3.00	3.10
E	0.169	0.173	0.177	4.30	4.40	4.50
e	0.026 BSC			0.65 BSC		
H	0.244	0.252	0.260	6.20	6.40	6.60
L	0.018	0.024	0.030	0.45	0.60	0.75
a	0°	5°	8°	0°	5°	8°

Note: Controlling dimensions are millimeters
TSSOP -0.034 grams unit weight



rev 1.0

Ordering Codes

Ordering Number	Marking	Package Type	QTY / Reel	Temperature
X278XA-08ST	X278XA	8 PIN SOIC, TUBE		See flow
X278XA-08SR	X278XA	8 PIN SOIC, TAPE & REEL	2,500	See flow
X278XA-08TT	X278XA	8 PIN TSSOP, TUBE		See flow
X278XA-08TR	X278XA	8 PIN TSSOP, TAPE & REEL	2,500	See flow
X278XB-08TT	X278XB	8 PIN TSSOP, TUBE		See flow
X278XB-08TR	X278XB	8 PIN TSSOP, TAPE & REEL	2,500	See flow

Device Ordering Information

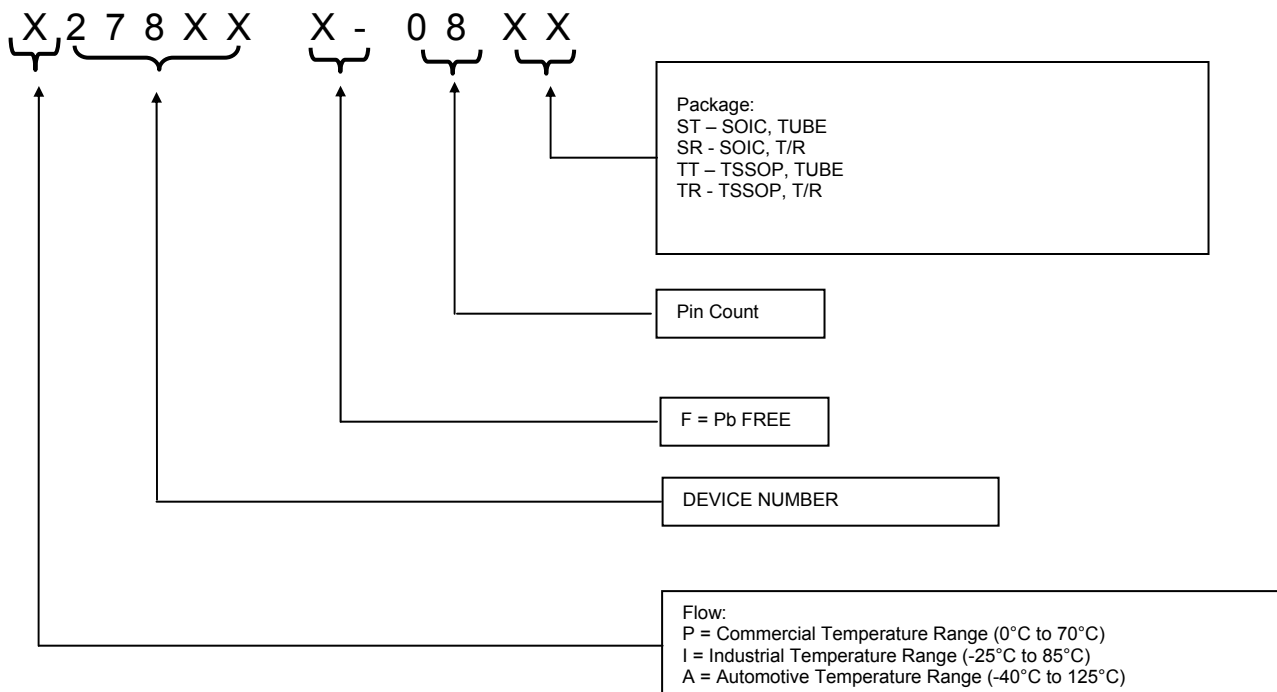



rev 1.0



Alliance Semiconductor Corporation
2595, Augustine Drive,
Santa Clara, CA 95054
Tel# 408-855-4900
Fax: 408-855-4999
www.alsc.com

Copyright © Alliance Semiconductor
All Rights Reserved
Part Number: P2781/82/84
Document Version: 1.0

© Copyright 2003 Alliance Semiconductor Corporation. All rights reserved. Our three-point logo, our name and Intelliwatt are trademarks or registered trademarks of Alliance. All other brand and product names may be the trademarks of their respective companies. Alliance reserves the right to make changes to this document and its products at any time without notice. Alliance assumes no responsibility for any errors that may appear in this document. The data contained herein represents Alliance's best data and/or estimates at the time of issuance. Alliance reserves the right to change or correct this data at any time, without notice. If the product described herein is under development, significant changes to these specifications are possible. The information in this product data sheet is intended to be general descriptive information for potential customers and users, and is not intended to operate as, or provide, any guarantee or warranty to any user or customer. Alliance does not assume any responsibility or liability arising out of the application or use of any product described herein, and disclaims any express or implied warranties related to the sale and/or use of Alliance products including liability or warranties related to fitness for a particular purpose, merchantability, or infringement of any intellectual property rights, except as express agreed to in Alliance's Terms and Conditions of Sale (which are available from Alliance). All sales of Alliance products are made exclusively according to Alliance's Terms and Conditions of Sale. The purchase of products from Alliance does not convey a license under any patent rights, copyrights; mask works rights, trademarks, or any other intellectual property rights of Alliance or third parties. Alliance does not authorize its products for use as critical components in life-supporting systems where a malfunction or failure may reasonably be expected to result in significant injury to the user, and the inclusion of Alliance products in such life-supporting systems implies that the manufacturer assumes all risk of such use and agrees to indemnify Alliance against all claims arising from such use.