



2SB1412

PNP EPITAXIAL SILICON TRANSISTOR

HIGH VOLTAGE SWITCHING TRANSISTOR

DESCRIPTION

The UTC 2SB1412 is an epitaxial planar type PNP silicon transistor.

FEATURES

- *Excellent DC current gain characteristics
- *Low $V_{CE(SAT)}$
 $V_{CE(SAT)} = -0.35V$ (Typ)
 $(I_C/I_B = -4A/-0.1A)$

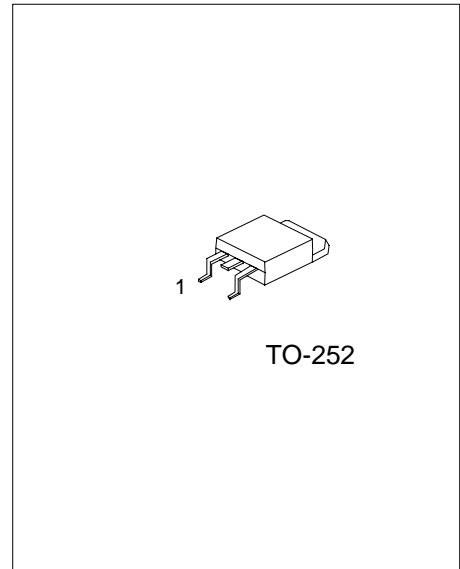

*Pb-free plating product number:2SB1412L

ORDERING INFORMATION

Order Number		Package	Pin Assignment			Packing
Normal	Lead Free Plating		1	2	3	
2SB1412-TN3-F-R	2SB1412L-TN3-F-R	TO-252	B	C	E	Tape Reel

<p>2SB1412L-TN3-F-R</p>	<p>(1) Packing Type (2) Pin Assignment (3) Package Type (4) Lead Plating</p>	<p>(1) R: Tape Reel (2) refer to Pin Assignment (3) TN3: TO-252 (4) L: Lead Free Plating, Blank: Pb/Sn</p>
-------------------------	---	---

2SB1412

PNP EPITAXIAL SILICON TRANSISTOR

■ ABSOLUTE MAXIMUM RATING (Ta=25°C , unless otherwise specified)

PARAMETER	SYMBOL	LIMITS	UNIT
Collector-Base Voltage	V _{CBO}	-30	V
Collector-Emitter Voltage	V _{CEO}	-20	V
Emitter-Base Voltage	V _{EBO}	-6	V
Collector Current(DC)	I _C	-5	A
Collector Current(PULSE) Single pulse, Pw=10ms	I _{CP}	-10	A
Collector Power Dissipation	P _D	1	W
Collector Power Dissipation (note2)	P _D	10(T _C =25°C)	W
Junction Temperature	T _J	+150	°C
Storage Temperature	T _{STG}	-40 ~ +150	°C

Note 1. Absolute maximum ratings are those values beyond which the device could be permanently damaged.

Absolute maximum ratings are stress ratings only and functional device operation is not implied.

2. When mounted on a 40*40*0.7mm ceramic board.

■ ELECTRICAL CHARACTERISTICS (Ta=25°C, unless otherwise specified)

PARAMETER	SYMBOL	TEST CONDITIONS	MIN	TYP	MAX	UNIT
Collector Base Breakdown Voltage	BV _{CBO}	I _C = -50 μ A	-30			V
Collector Emitter Breakdown Voltage	BV _{CEO}	I _C = -1mA	-20			V
Emitter Base Breakdown Voltage	BV _{EBO}	I _E = -50 μ A	-6			V
Collector Cut-Off Current	I _{CBO}	V _{CB} = -20V			-0.5	μ A
Emitter Cut-Off Current	I _{EBO}	V _{EB} = -5V			-0.5	μ A
DC Current Transfer Ratio	h _{FE}	V _{CE} = -2V, I _C = -0.5A	82		390	
Collector-Emitter Saturation Voltage	V _{CE(SAT)}	I _C /I _B = -4A/-0.1A			-1.0	V
Transition Frequency	f _T	V _{CE} = -6V, I _E = 50 mA, f=30MHz		120		MHz
Output Capacitance	C _{ob}	V _{CB} = -20V, I _E = 0 A, f=1MHz		60		pF

■ CLASSIFICATION OF hFE

RANK	P	Q	R
RANGE	82-180	120-270	180-390

TYPICAL CHARACTERISTICS

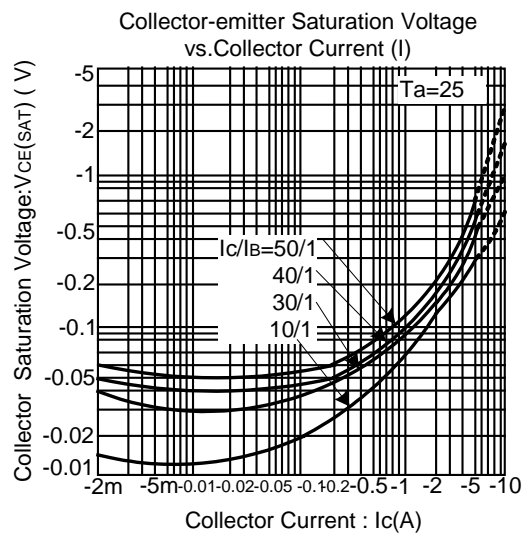
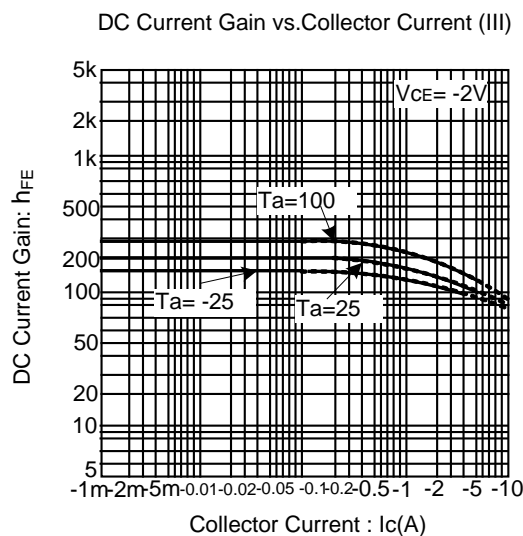
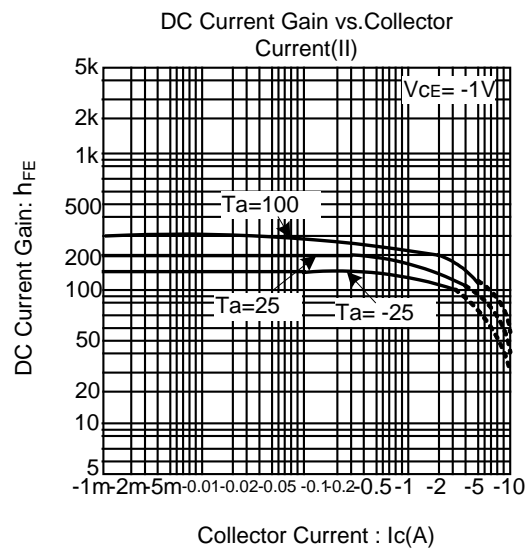
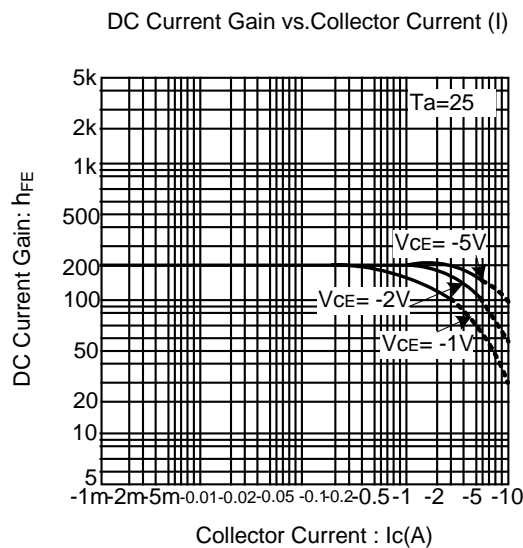
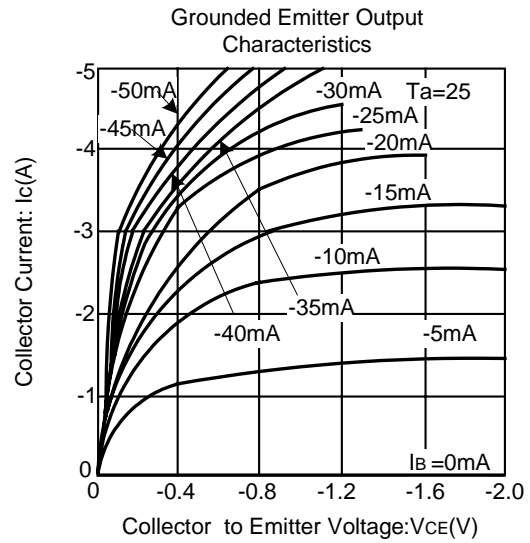
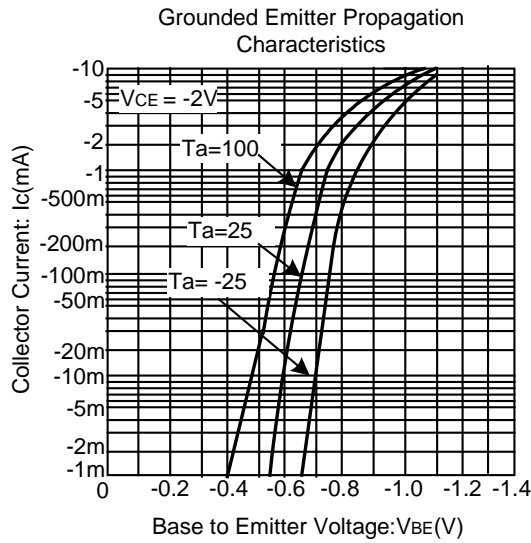

■ TYPICAL CHARACTERISTICS(Cont.)

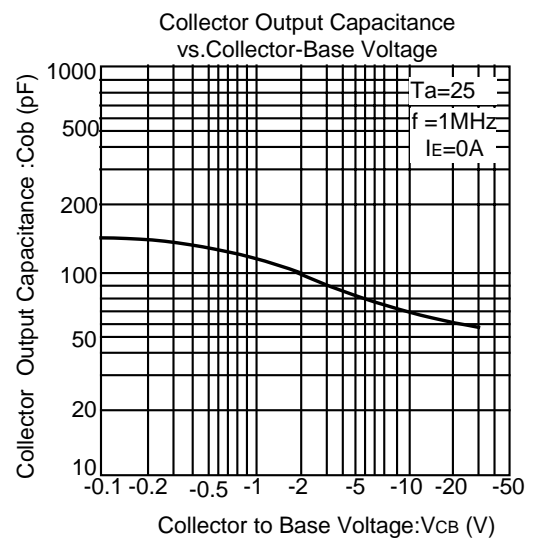
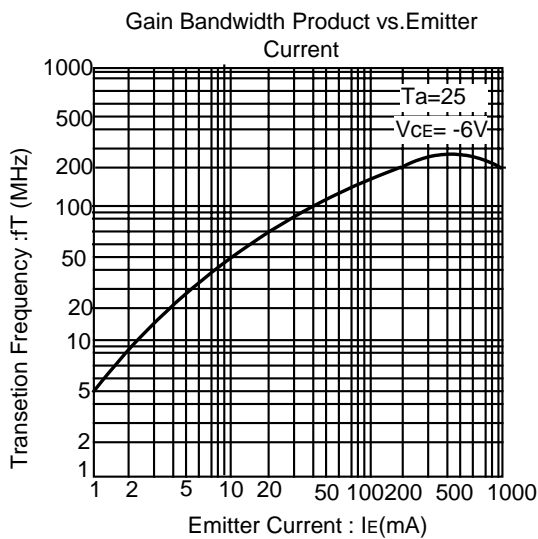
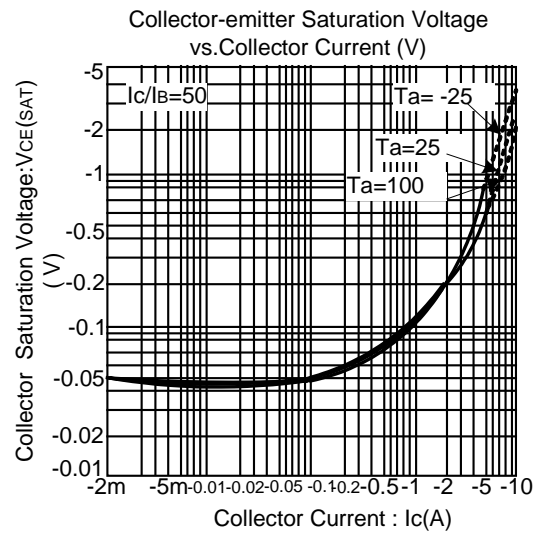
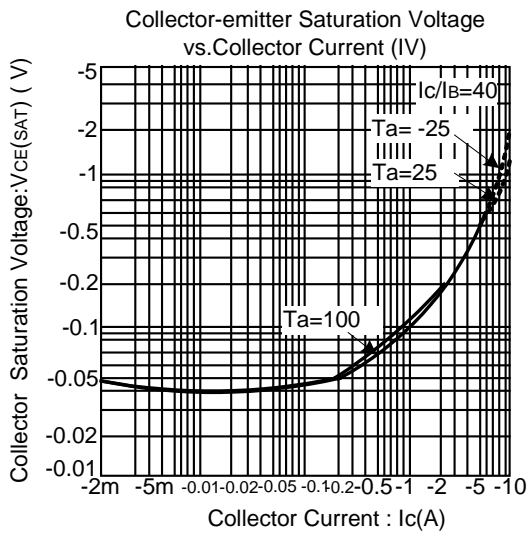
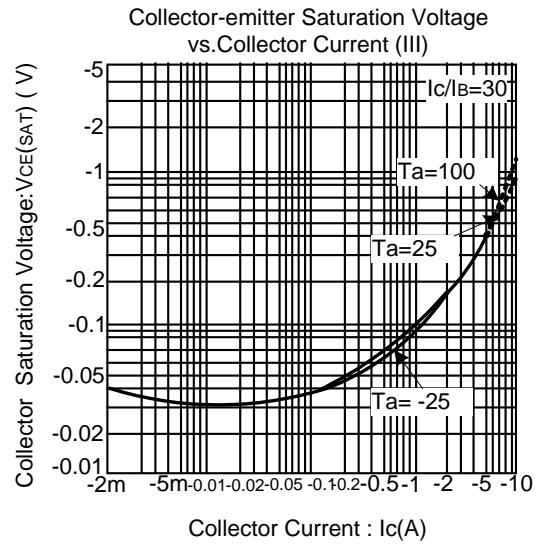
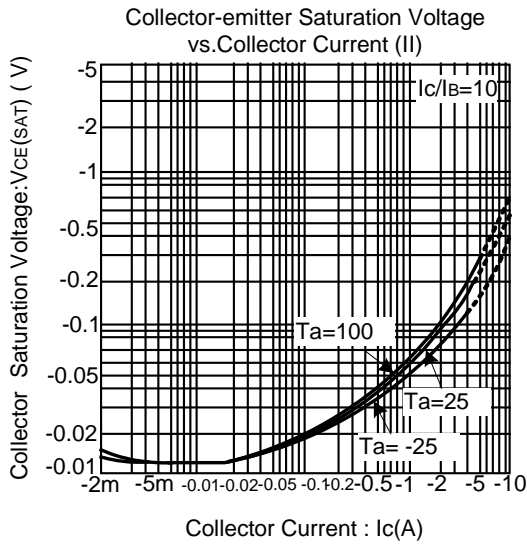

■ TYPICAL CHARACTERISTICS(Cont.)

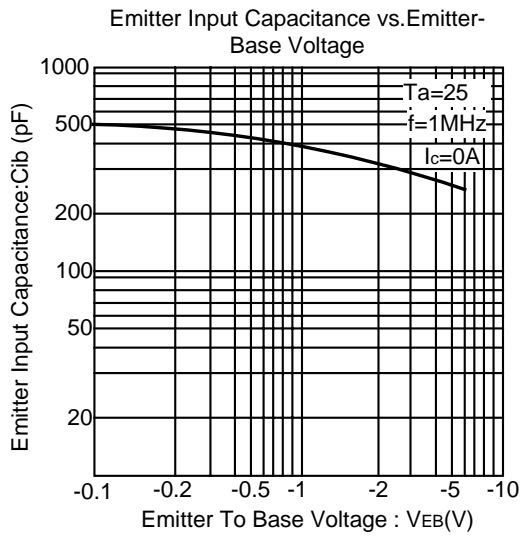

UTC assumes no responsibility for equipment failures that result from using products at values that exceed, even momentarily, rated values (such as maximum ratings, operating condition ranges, or other parameters) listed in products specifications of any and all UTC products described or contained herein. UTC products are not designed for use in life support appliances, devices or systems where malfunction of these products can be reasonably expected to result in personal injury. Reproduction in whole or in part is prohibited without the prior written consent of the copyright owner. The information presented in this document does not form part of any quotation or contract, is believed to be accurate and reliable and may be changed without notice.