

# HMCS43C(HD44750)

# HMCS43CL(HD44758)

The HMCS43C is the CMOS 4-bit single chip microcomputer which contains ROM, RAM, I/O and Timer/Event Counter on single chip. The HMCS43C is designed to perform efficient controller function as well as arithmetic function for both binary and BCD data. The CMOS technology of the HMCS43C provides the flexibility of microcomputers for battery powered and battery back-up applications.

## ■ FEATURES

- 4-bit Architecture
- 1,024 Words of Program ROM (10 bits/Word)
- 64 Words of Pattern ROM (10 bits/Word)
- 80 Digits of Data RAM (4 bits/Digit)
- 32 I/O Lines and 2 External Interrupt Lines
- Timer/Event Counter
- Instruction Cycle Time: HMCS43C; 10  $\mu$ s  
HMCS43CL; 20  $\mu$ s
- All Instructions except One Instruction; Single Word and Single Cycle
- BCD Arithmetic Instructions
- Pattern Generation Instruction
  - Table Look Up Capability —
- Powerful Interrupt Function
  - 3 Interrupt Sources
    - └ 2 External Interrupt Lines
    - └ Timer/Event Counter
  - Multiple Interrupt Capability
- Bit Manipulation Instructions for Both RAM and I/O
- Option of I/O Configuration Selectable on Each Pin; Pull Up MOS or CMOS or Open Drain
- Built-in Oscillator
- Built-in Power-on Reset Circuit (HMCS43C only)
- Low Operating Power Dissipation; 2mW typ.
- Stand-by Mode (RAM Data Hold); 50  $\mu$ W max.
- CMOS Technology
- Single Power Supply: HMCS43C; 5V  $\pm$  10%  
HMCS43CL; 2.5V to 5.5V

HMCS43C.HMCS43CL

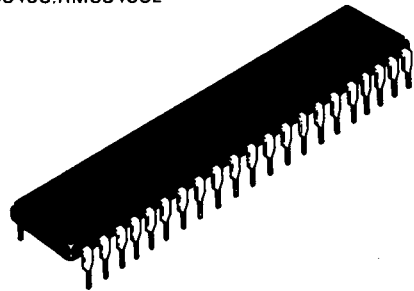

(DP-42)

HMCS43C

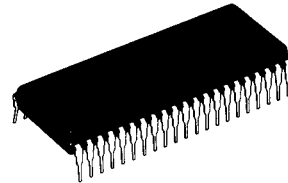

(DP-42S)

## ■ PIN ARRANGEMENT

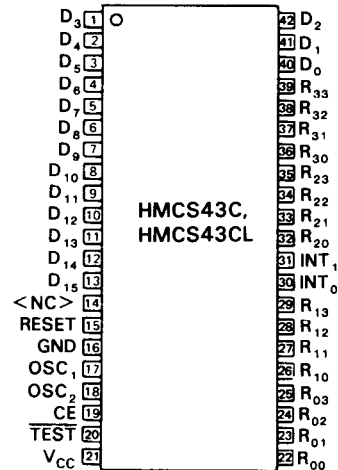

(Top View)

■ BLOCK DIAGRAM

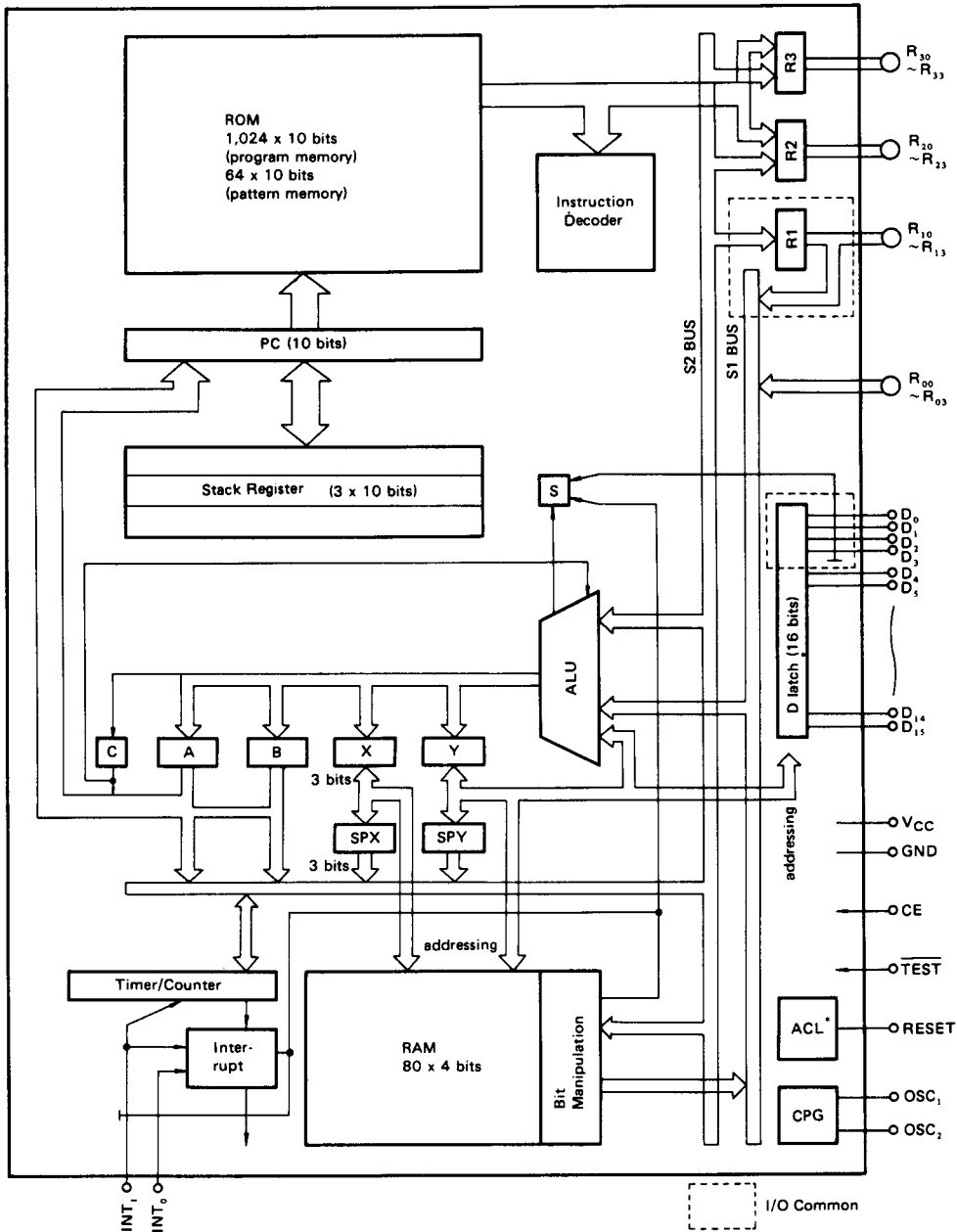

\* Power-on Reset Circuit  
(ACL) is not built in HMCS43CL.

www.DataSheet4U.com

■ **HMCS43C ELECTRICAL CHARACTERISTICS** ( $V_{CC}=5V\pm 10\%$ )

● **ABSOLUTE MAXIMUM RATINGS**

Item	Symbol	Value	Unit	Remarks
Supply Voltage	$V_{CC}$	-0.3 to +7.0	V	
Pin Voltage (1)	$V_{T1}$	-0.3 to $V_{CC}+0.3$	V	Except for pins specified by $V_{T2}$
Pin Voltage (2)	$V_{T2}$	-0.3 to +10.0	V	Applied to open drain output pins
Maximum Total Output Current (1)	$-\sum I_{O1}$	45	mA	[NOTE 3]
Maximum Total Output Current (2)	$\sum I_{O2}$	45	mA	[NOTE 3]
Operating Temperature	$T_{opr}$	-20 to +75	°C	
Storage Temperature	$T_{stg}$	-55 to +125	°C	

[NOTE 1] Permanent LSI damage may occur if maximum ratings are exceeded. Normal operation should be under the conditions of "ELECTRICAL CHARACTERISTICS-1, -2." If these conditions are exceeded, it could affect reliability of LSI.

[NOTE 2] All voltages are with respect to GND.

[NOTE 3] Maximum Total Output Current is total sum of output currents which can flow out (or flow in) simultaneously.

● **ELECTRICAL CHARACTERISTICS-1** ( $V_{CC}=5V\pm 10\%$ ,  $T_a=-20$  to  $+75^\circ\text{C}$ )

Item	Symbol	Test Conditions	Value			Unit	Note	
			min	typ	max			
Input "Low" Voltage	$V_{IL}$		-	-	1.0	V		
Input "High" Voltage	$V_{IH}$		$V_{CC}-1.0$	-	$V_{CC}$	V		
Output "Low" Voltage	$V_{OL}$	$I_{OL}=1.6\text{mA}$	-	-	0.8	V		
Output "High" Voltage (1)	$V_{OH1}$	$-I_{OH}=1.0\text{mA}$	2.4	-	-	V	4	
Output "High" Voltage (2)	$V_{OH2}$	$-I_{OH}=0.01\text{mA}$	$V_{CC}-0.3$	-	-	V	5	
Interrupt Input Hold Time	$t_{INT}$		$2 \cdot T_{inst}$	-	-	$\mu\text{s}$		
Interrupt Input Fall Time	$t_{fINT}$		-	-	50	$\mu\text{s}$		
Interrupt Input Rise Time	$t_{rINT}$		-	-	50	$\mu\text{s}$		
Output "High" Current	$I_{OH}$	$V_{OH}=10\text{V}$	-	-	3	$\mu\text{A}$	3	
Input Leakage Current	$I_{IL}$	$V_{in}=0$ to $V_{CC}$	-	-	1.0	$\mu\text{A}$	2	
Pull up MOS Current	$-I_P$	$V_{CC}=5\text{V}$	60	-	250	$\mu\text{A}$		
Supply Current (1)	$I_{CC1}$	$V_{in}=V_{CC}$ , Ceramic Filter Oscillation	-	-	2.0	mA	6	
Supply Current (2)	$I_{CC2}$	$V_{in}=V_{CC}$ , $R_f$ Oscillation, External Clock Operation	-	-	1.0	mA	6	
Standby I/O Leakage Current	$I_{LS}$	CE=1.0V	$V_{in}=0$ to $V_{CC}$	-	-	1	$\mu\text{A}$	2, 7
			$V_{in}=0$ to 10V	-	-	3	$\mu\text{A}$	3, 7
Standby Supply Current	$I_{CCS}$	$V_{in}=V_{CC}$ , CE=0.2V	-	-	10	$\mu\text{A}$	8	
<b>External Clock Operation</b>								
External Clock Frequency	$f_{cp}$		200	400	440	kHz		
External Clock Duty	Duty		45	50	55	%		
External Clock Rise Time	$t_{rcp}$		0	-	0.2	$\mu\text{s}$		
External Clock Fall Time	$t_{fcp}$		0	-	0.2	$\mu\text{s}$		
Instruction Cycle Time	$T_{inst}$	$T_{inst}=4/f_{cp}$	9.1	10	20	$\mu\text{s}$		
<b>Internal Clock Operation (<math>R_f</math> Oscillation)</b>								
Clock Oscillation Frequency	$f_{OSC}$	$R_f=91\text{k}\Omega \pm 2\%$	320	-	480	kHz		
Instruction Cycle Time	$T_{inst}$	$T_{inst}=4/f_{OSC}$	8.4	-	12.5	$\mu\text{s}$		
<b>Internal Clock Operation (Ceramic Filter Oscillation)</b>								
Clock Oscillation Frequency	$f_{OSC}$	Ceramic Filter	392	-	408	kHz		
Instruction Cycle Time	$T_{inst}$	$T_{inst}=4/f_{OSC}$	9.8	-	10.2	$\mu\text{s}$		

[NOTE 1] All voltages are with respect to GND.

[NOTE 2] This is applied to RESET, CE, OSC<sub>v</sub>, INT<sub>v</sub>, INT<sub>v</sub>, and CMOS type of output or I/O or input pins.



[NOTE 3] This is applied to the Open Drain type of Output pins.

[NOTE 4] This is applied to the CMOS type of I/O or Output pins.

[NOTE 5] This is applied to the With Pull up MOS or CMOS type of I/O or Output pins.

[NOTE 6] I/O current is excluded.

[NOTE 7] The Standby I/O Leakage Current is the I/O leakage current in the "Data Hold" mode.

[NOTE 8] I/O current is excluded.

The Standby Supply Current is the supply current at  $V_{CC} = 5V \pm 10\%$  in the "Data Hold" mode. The supply current in the case where the supply voltage falls to the Data Hold Voltage is called the Data Hold Current ( $I_{DR}$ ), and it is shown in "ELECTRICAL CHARACTERISTICS-2."

● ELECTRICAL CHARACTERISTICS-2 ( $T_a = -20$  to  $+75^\circ C$ )

(i) Reset

Item	Symbol	Test Conditions	Value		Unit
			min	max	
Power Supply Rise Time	$t_{rCC}$	$CE = V_{CC}$ , Built-in Reset	0.1	10	ms
Power Supply OFF Time	$t_{OFF}$	$CE = V_{CC}$ , Built-in Reset	1	—	ms
CE Rise Time	$t_{rCE}$	$V_{CC} = 4.5$ to $5.5V$ , Built-in Reset	—	10	ms
CE "Low" Hold Time	$t_{CD}$	$V_{CC} = 4.5$ to $5.5V$ , Built-in Reset	1	—	ms
RESET Pulse Width (1)	$t_{RST1}$	External Reset, $V_{CC} = 4.5$ to $5.5V$ , $CE = V_{CC}$ ; ( $R_f$ Oscillation, External Clock Operation)	1	—	ms
		External Reset, $V_{CC} = 4.5$ to $5.5V$ , $CE = V_{CC}$ (Ceramic Filter Oscillation)	4	—	
RESET Pulse Width (2)	$t_{RST2}$	$V_{CC} = 4.5$ to $5.5V$ , External Reset, $CE = V_{CC}$	$2 \cdot T_{inst}$	—	$\mu s$
RESET Fall Time	$t_{fRST}$	$\overline{HLT} = V_{CC}$	—	20	ms
RESET Rise Time	$t_{rRST}$	$\overline{HLT} = V_{CC}$	—	20	ms

[NOTE] All voltages are with respect to GND.

The built-in reset circuit is used in the following two ways.

- Activate the supply voltage in the state of  $V_{CC} = CE$ . [NOTE 2]
- Bring CE "Low" level to "High" with keeping  $V_{CC}$  applying. [NOTE 3]

(ii) Data Hold

Item	Symbol	Test Conditions	Value		Unit
			min	max	
Data Hold Voltage	$V_{DR}$	$CE = 0.2V$	2.0	—	V
Data Hold Current	$I_{DR}$	$CE = 0.2V$ , $V_{DR} = 2.0V$	—	10	$\mu A$
Data Save Time	$t_{CDR}$		100	—	$\mu s$
Data Recovery Time	$t_{RCR}$		100	—	$\mu s$
Operation Recovery Time	$t_{RC}$	External Clock Operation, $R_f$ Oscillation	0.1	—	ms
		Ceramic Filter Oscillation	4	—	

[NOTE] All voltages are with respect to GND.

■ **HMCS43CL ELECTRICAL CHARACTERISTICS** ( $V_{CC}=2.5V$  to  $5.5V$ )

● **ABSOLUTE MAXIMUM RATINGS**

Item	Symbol	Value	Unit	Remarks
Supply Voltage	$V_{CC}$	$-0.3$ to $+7.0$	V	
Pin Voltage (1)	$V_{T1}$	$-0.3$ to $V_{CC}+0.3$	V	Except for pins specified by $V_{T2}$
Pin Voltage (2)	$V_{T2}$	$-0.3$ to $+10.0$	V	Applied to open-drain output pins.
Maximum Total Output Current (1)	$-\Sigma I_{O1}$	45	mA	[NOTE 3]
Maximum Total Output Current (2)	$\Sigma I_{O2}$	45	mA	[NOTE 3]
Operating Temperature	$T_{opr}$	$-20$ to $+75$	$^{\circ}C$	
Storage Temperature	$T_{stg}$	$-55$ to $+125$	$^{\circ}C$	

[NOTE 1] Permanent LSI damage may occur if maximum ratings are exceeded. Normal operation should be under the conditions of "ELECTRICAL CHARACTERISTICS-1, -2." If these conditions are exceeded, it could affect reliability of LSI.

[NOTE 2] All voltages are with respect to GND.

[NOTE 3] Maximum Total Output Current is total sum of output currents which can flow out (or flow in) simultaneously.

● **ELECTRICAL CHARACTERISTICS-1** ( $V_{CC}=2.5$  to  $5.5V$ ,  $T_a=-20$  to  $+75^{\circ}C$ )

Item	Symbol	Test Conditions	Value			Unit	Note	
			min.	typ.	max.			
Input "Low" Voltage	$V_{IL}$		—	—	$0.15 \cdot V_{CC}$	V		
Input "High" Voltage	$V_{IH}$		$0.85 \cdot V_{CC}$	—	$V_{CC}$	V		
Output "Low" Voltage	$V_{OL}$	$I_{OL}=0.4mA$	—	—	0.4	V		
Output "High" Voltage	$V_{OH}$	$-I_{OH}=0.08mA$	$V_{CC}-0.4$	—	—	V	4	
Interrupt Input Fall Time	$t_{INT}$		—	—	50	$\mu s$		
Interrupt Input Rise Time	$t_{INT}$		—	—	50	$\mu s$		
Interrupt Input Hold Time	$t_{INT}$		$2 \cdot T_{inst}$	—	—	$\mu s$		
Output "High" Current	$I_{OH}$	$V_{OH}=10V$	—	—	3	$\mu A$	3	
Input Leakage Current	$I_{IL}$	$V_{in}=0$ to $V_{CC}$	—	—	1.0	$\mu A$	2	
Pull up MOS Current	$-I_p$	$V_{CC}=3V$	10	—	80	$\mu A$		
Supply Current	$I_{CC}$	$V_{in}=V_{CC}$ , $V_{CC}=3V$ $(f_{OSC}/f_{CP}=200kHz)$ $R_f$ Oscillation, External Clock Operation	—	—	105	$\mu A$	5	
Standby I/O Leakage Current	$I_{LS}$	$HLT=0.5V$	$V_{in}=0$ to $V_{CC}$	—	—	1	$\mu A$	2, 6
			$V_{in}=0$ to $10V$	—	—	3		3, 6
Standby Supply Current	$I_{CCS}$	$V_{in}=V_{CC}$ , $HLT=0.1V$	$V_{CC}=2.5$ to $3.5V$	—	—	6	$\mu A$	7
			$V_{CC}=2.5$ to $5.5V$	—	—	10		

(to be continued)

Item	Symbol	Test Conditions	Value			Unit	Note
			min	typ	max		
<b>External Clock Operation</b>							
External Clock Frequency	$f_{cp}$		130	200	240	kHz	
External Clock Duty	Duty		45	50	55	%	
External Clock Rise Time	$t_{rcp}$		0	—	0.2	$\mu s$	
External Clock Fall Time	$t_{fcp}$		0	—	0.2	$\mu s$	
Instruction Cycle Time	$T_{inst}$	$T_{inst} = 4/f_{cp}$	16.8	20	30.8	$\mu s$	
<b>Internal Clock Operation (<math>R_f</math> Oscillation)</b>							
Clock Oscillation Frequency	$f_{osc}$	$R_f = 180k\Omega \pm 2\%$ , $V_{CC} = 2.5$ to $3.5V$	130	—	250	kHz	
		$R_f = 180k\Omega \pm 2\%$ , $V_{CC} = 2.5$ to $5.5V$	130	—	350		
Instruction Cycle Time	$T_{inst}$	$T_{inst} = 4/f_{osc}$ , $V_{CC} = 2.5$ to $3.5V$	16	—	30.8	$\mu s$	
		$T_{inst} = 4/f_{osc}$ , $V_{CC} = 2.5$ to $5.5V$	11.4	—	30.8		

[NOTE 1] All voltages are with respect to GND.

[NOTE 2] This is applied to RESET, CE, OSC<sub>1</sub>, INT<sub>0</sub>, INT<sub>1</sub>, and CMOS type of output or I/O or input pins.

[NOTE 3] This is applied to the Open Drain type of Output pins.

[NOTE 4] This is applied to the CMOS type of I/O or Output pins.

[NOTE 5] I/O current is excluded.

[NOTE 6] The Standby I/O Leakage Current is the I/O leakage current in the "Data Hold" mode.

[NOTE 7] I/O current is excluded.

The Standby Supply Current is the supply current at  $V_{CC} = 2.5V$  to  $5.5V$  in the "Data Hold" mode. The supply current in the case where the supply voltage falls to the Data Hold Voltage is called the Data Hold Current ( $I_{DR}$ ), and it is shown in "ELECTRICAL CHARACTERISTICS-2."

● ELECTRICAL CHARACTERISTICS-2 ( $T_a = -20$  to  $+75^\circ C$ )

(i) Reset

Item	Symbol	Test Conditions	Value		Unit
			min	max	
RESET Pulse Width (1)	$t_{RST1}$	External Reset, $V_{CC} = 2.5$ to $5.5V$ , $CE = V_{CC}$ ( $R_f$ Oscillation, External Clock Operation)	2	—	ms
RESET Pulse Width (2)	$t_{RST2}$	External Reset, $V_{CC} = 2.5$ to $5.5V$ $CE = V_{CC}$	$2 \cdot T_{inst}$	—	$\mu s$
RESET Fall Time	$t_{RST}$	$HLT = V_{CC}$	—	20	ms
RESET Rise Time	$t_{RST}$	$HLT = V_{CC}$	—	20	ms

(ii) Data Hold

Item	Symbol	Test Conditions	Value		Unit
			min	max	
Data Hold Voltage	$V_{DR}$	$CE = 0.1V$	2.0	—	V
Data Hold Current	$I_{DR}$	$CE = 0.1V$ , $V_{DR} = 2.0V$	—	4	$\mu A$
Data Save Time	$t_{CDR}$		200	—	$\mu s$
Data Recovery Time	$t_{RCR}$		200	—	$\mu s$
Operation Recovery Time	$t_{RC}$	$R_f$ Oscillation, $V_{CC} = 2.5$ to $5.5V$ External Clock Operation	0.2	—	ms

[NOTE] All voltages are with respect to GND.

■ **SIGNAL DESCRIPTION**

The input and output signals for the HMCS43C, shown in PIN ARRANGEMENT, are described in the following paragraphs.

● **V<sub>CC</sub> and GND**

Power is supplied to the HMCS43C using these pins. V<sub>CC</sub> is power and GND is the ground connection.

● **RESET**

This pin allows resets the HMCS43C independently of the automatic resetting capability (ACL; Built-in Reset Circuit) already in the HMCS43C. The HMCS43C can be reset by pulling RESET high.  
Refer to RESET FUNCTION for additional information.

● **CE**

When CE is set to "0" (Low) level, the power supply of logic parts except RAM becomes OFF automatically by the internal circuit of LSI.

Then the data hold of RAM is performed at very low power dissipation.

Refer to DATA HOLD FUNCTION for additional information.

● **OSC<sub>1</sub> and OSC<sub>2</sub>**

These pins provide control input for the built-in oscillator circuit. Resistor and capacitor, ceramic filter circuit, or an external oscillator can be connected to these pins to provide a system clock with various degrees of stability/cost tradeoffs. Lead length and stray capacitance on these two pins should be minimized.

Refer to OSCILLATOR for recommendations about these pins.

● **TEST**

This pin is not for user application and must be connected to V<sub>CC</sub>.

● **INT<sub>0</sub> and INT<sub>1</sub>**

These pins generate interrupt request to the HMCS43C.  
Refer to INTERRUPTS for additional information.

● **R<sub>00</sub> to R<sub>03</sub>**

These 4 lines are a 4-bit input channel.  
Refer to INPUT/OUTPUT for additional information.

● **R<sub>10</sub> to R<sub>13</sub>**

These 4 lines are one 4-bit Input/Output Common Channel. 4-bit register (Data I/O Register) is attached to this channel. This channel is directly addressed by the operand of an instruction.  
Refer to INPUT/OUTPUT for additional information.

● **R<sub>20</sub> to R<sub>23</sub>, R<sub>30</sub> to R<sub>33</sub>**

These 8 lines are two 4-bit output channels. 4-bit registers are attached to these channels. Each channel is directly addressed by the operand of an instruction.  
Refer to INPUT/OUTPUT for additional information.

● **D<sub>0</sub> to D<sub>3</sub>**

These lines are four 1-bit Discrete Input/Output Common Pins. The 1-bit latches are attached to these pins. Each pin is addressed by the Y register. These pins are also addressed directly by the operand of input/output instruction.  
Refer to INPUT/OUTPUT for additional information.

● **D<sub>4</sub> to D<sub>15</sub>**

These lines are twelve 1-bit Discrete Output Pins. The 1-bit latches are attached to these pins. Each pin is addressed by the Y register.  
Refer to INPUT/OUTPUT for additional information.

■ **ROM**

● **ROM Address Space**

ROM is used as a memory for the instructions and the patterns (constants). The instruction used in the HMCS43C consists of 10 bits. These 10 bits are called "a word", which is a unit for writing into ROM.

The ROM address is composed of the program area (page 0 to page 15) and the pattern area (page 30). (64 words/page).

The ROM capacity is 1,088 words (1 word = 10 bits) in all. Only the program area can contain both the instructions and the patterns (constants).

The ROM address space is shown in Figure 1.

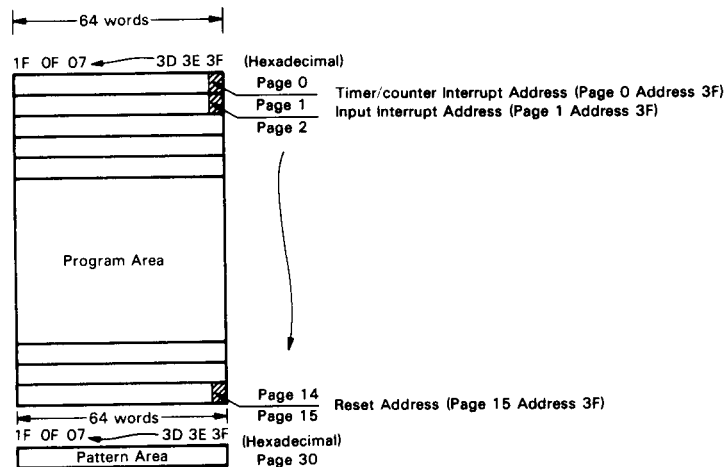

Figure 1 ROM Address Space

• **Program Counter (PC)**

The program counter is used for addressing of ROM. It consists of the page part and the address part as shown in Figure 2.

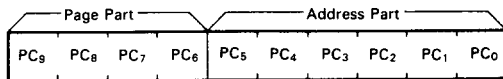

Figure 2 Configuration of Program Counter

Once a certain value is loaded into a page part, it is unchanged until other value is loaded by the program. Any number among 0 to 15 can be set in the page part.

The address part is a 6-bit polynomial counter and counts up for each instruction cycle time. The sequence in the decimal and hexadecimal system is shown in Table 1. This sequence forms a loop and has neither the starting nor ending point. It doesn't generate an overflow carry. Consequently, the program on a same page is executed in order unless the value of the page part is changed.

Table 1 Program Counter Address Part Sequence

Decimal	Hexadecimal	Decimal	Hexadecimal	Decimal	Hexadecimal
63	3F	5	05	9	09
62	3E	11	0B	19	13
61	3D	23	17	38	26
59	3B	46	2E	12	0C
55	37	28	1C	25	19
47	2F	56	38	50	32
30	1E	49	31	37	25
60	3C	35	23	10	0A
57	39	6	06	21	15
51	33	13	0D	42	2A
39	27	27	1B	20	14
14	0E	54	36	40	28
29	1D	45	2D	16	10
58	3A	26	1A	32	20
53	35	52	34	0	00
43	2B	41	29	1	01
22	16	18	12	3	03
44	2C	36	24	7	07
24	18	8	08	15	0F
48	30	17	11	31	1F
33	21	34	22		
2	02	4	04		

• **Designation of ROM Address and ROM Code**

The page part of the ROM address is represented by decimal and the address part is divided into 2 parts (2 bits and 4 bits) and represented by hexadecimal.

One word (10 bits) is divided into three parts (2 bits, 4 bits and 4 bits from the most significant bit O<sub>10</sub>) and represented by hexadecimal. The examples are shown in Figure 3.

(a) ROM Address

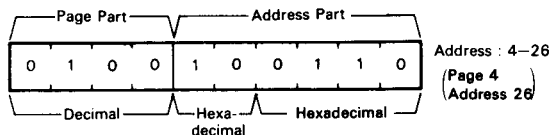

(b) ROM Code

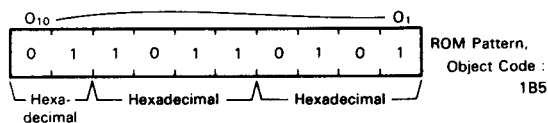

Figure 3 Designation of ROM Address and ROM Code



**■ PATTERN GENERATION**

The pattern (constants) can be accessed by the pattern instruction (P). The pattern can be written in any address of the ROM address space.

**• Reference**

ROM addressing for reference of the patterns is achieved by modifying the program counter with the accumulator, the B register, the Carry F/F and the operand p. Figure 4 shows how to modify the program counter. The address part is replaced with the accumulator and the lower 2 bits of B register, while the page part is ORed with the upper 2 bits of B register, the Carry F/F and the operand p (p<sub>0</sub>). The upper bit (p<sub>1</sub>) of the operand is for referring to the pattern area.

The contents of the program counter is only modified apparently and is not changed. Then the address is counted up after the execution of the pattern instruction and the next instruction is executed.

The pattern instruction is executed in 2 cycles.

Even when interrupt is enable, interrupt is disabled in the second cycle of the pattern instruction. However, the interrupt request is latched into the interrupt request F/F.

**• Generation**

The pattern of referred ROM address is generated as the following two ways:

- (i) The pattern is loaded into the accumulator and B register.
- (ii) The pattern is loaded into the Data I/O registers R2 and R3.

The command bits (O<sub>9</sub>, O<sub>10</sub>) in the pattern determine which way is taken.

Mode (i) is performed when O<sub>9</sub> is "1" and mode (ii) is performed when O<sub>10</sub> is "1".

Mode (i) and mode (ii) are simultaneously performed when both O<sub>9</sub> and O<sub>10</sub> are "1".

The correspondence of each bit of the pattern is shown in Figure 5.

Examples of how to use the pattern instruction is shown in Table 2:

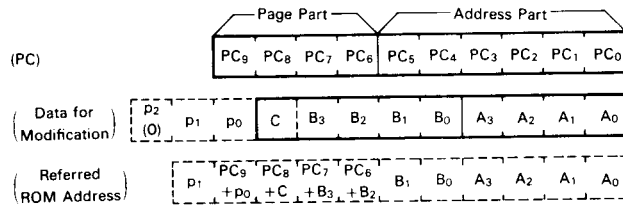

Figure 4 ROM Addressing for Pattern Generation

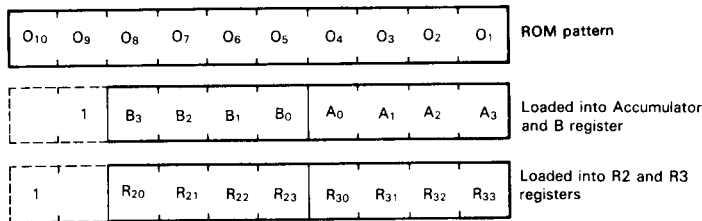

Figure 5 Correspondence of Each Bit of Pattern

Table 2 Example of how to use Pattern Instruction

Before Execution					Referred ROM Address	Pattern	After Execution			
PC Value	p	C	B	A			B	A	R2	R3
0-3F	1	0	A	0	10-20	123	2	C	—	—
0-3F	3	1	8	8	30-08	223	—	—	4	C
14-00	2	0/1	0	9	30-09	323	2	C	4	C
14-00	2	0/1	F	9	31-39					

"—" means that the value is unchanged after the execution.  
 "0/1" means that either "0" or "1" will do.

**■ BRANCH**

ROM is accessed according to the program counter sequence and the program is executed. In order to jump to any address out of the sequence, there are four ways.

They are explained in the following paragraphs.

**• BR**

By BR instruction, the program branches to an address in the

current page.

The lower 6 bits of ROM Object Code (operand a, O<sub>6</sub> to O<sub>1</sub>) are transferred to the lower 6 bits of the program counter. This instruction is a conditional instruction and executed only when the Status F/F is "1". If it is "0", the instruction is skipped and the Status F/F becomes "1". The operation is shown in Figure 6.

• **LPU**

By LPU instruction, a jump between pages is performed. The lower 4 bits of the ROM Object Code (operand u) are transferred to the page part of the program counter with a delay of 1 instruction cycle time. Therefore, the cycle just after the issuing of this instruction is on the same page and the page jump is performed at the next cycle.

This instruction is a conditional instruction and performed only when the Status is "1". But the Status is unchanged (remains "0") even if it is skipped. The operation is shown in Figure 7.

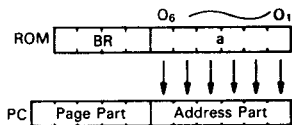

Figure 6 BR Operation

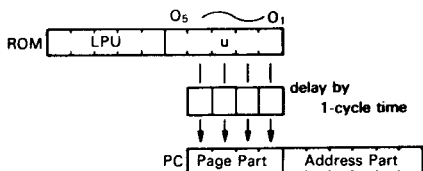

Figure 7 LPU Operation

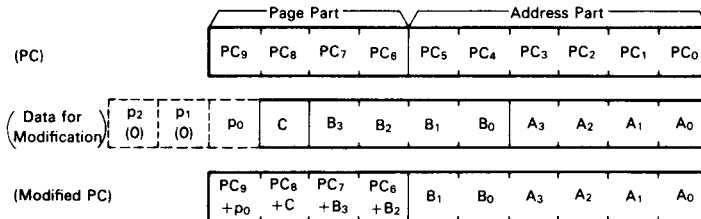

Figure 8 Modification of Program Counter by TBR Instruction

■ **SUBROUTINE JUMP**

There are two types of subroutine jumps. They are explained in the following paragraphs.

• **CAL**

By CAL instruction, subroutine jump to an address in the Subroutine Page is performed.

The Subroutine Page is page 0.

The address next to CAL instruction address is pushed onto the stack ST1 and the contents of the stacks ST1, ST2 are pushed onto the stacks ST2 and ST3 respectively as shown in Figure 9.

The page part of the program counter is 0. The lower 6 bits (operand a,  $O_6$  to  $O_1$ ) of the ROM Object Code are transferred to the address part of the program counter.

The HMCS43C has 3 levels of stack (ST1, ST2 and ST3) which allows the programmer to use up to 3 levels of subroutine jumps (including interrupts).

• **BRL**

By BRL instruction, the program branches to an address in any page.

This instruction is a macro instruction of LPU and BR instructions, which is divided into two steps as follows.

```
BRL a - b → LPU a
< Jump to address b on page a > BR b
```

BRL instruction is a conditional instruction because of its characteristics of LPU and BR instructions, and is executed only when the Status F/F is "1". If the Status F/F is "0", the instruction is skipped and the Status F/F becomes "1".

• **TBR (Table Branch)**

By TBR instruction, the program branches referring to the table.

The program counter is modified with the accumulator, the B register, the Carry F/F, the operand p. The method for modification is shown in Figure 8.

The accumulator and the lower 2 bits of B register are assigned into the address part of the program counter. The upper 2 bits of B register, Carry F/F, and the operand p<sub>1</sub>, p<sub>0</sub> are ORed with the page part of the program counter.

TBR instruction is executed regardless of the Status F/F, and does not affect the Status F/F.

CAL is a conditional instruction and executed only when the Status F/F is "1". If the Status F/F is "0", it is skipped and the Status F/F changes to "1".

• **CALL**

By CALL instruction, subroutine jump to an address in any page is performed.

This instruction is a macro instruction of LPU and CAL. The subroutine jump to the page specified by LPU enables the subroutine jump to an optional address.

```
CALL a - b → LPU a
< Subroutine jump to address b on page a > CAL b
```

CALL instruction is conditional because of its characteristics of LPU and CAL instructions and is executed when the Status F/F is "1". If the Status F/F is "0", it is skipped and the Status F/F changes to "1".

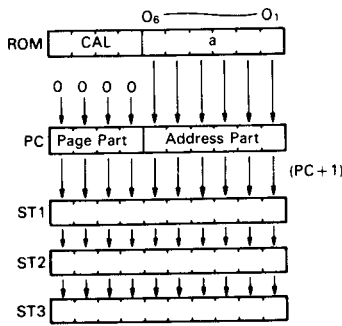

Figure 9 Subroutine Jump Stacking Order

■ **RAM**

RAM is a memory used for storing data and saving the con-

tents of the registers. Its capacity is 80 digits (320 bits) where one digit consists of 4 bits.

Addressing of RAM is performed by a matrix of the file No. and the digit No.

The file No. is set in the X register and the digit No. in the Y register for reading, writing or testing. Specific digits in RAM can be addressed not via the X register and Y register. These digits, 16 digits (MR0 to MR16), are called "Memory Register (MR)". The memory register can be exchanged with the accumulator by XAMR instruction.

The RAM address space is shown in Figure 10.

If an instruction consists of a simultaneous read/write operation of RAM (exchange between the contents of RAM and those of the register), the writing data doesn't affect the reading data because read operation precedes write operation.

The RAM bit manipulation instruction enables any addressed RAM bit to be set, reset or tested. The bit assignment is specified by the operand n of the instruction.

The bit test makes the Status F/F "1" when the assigned bit is "1" and makes it "0" when the assigned bit is "0".

Correspondence between the RAM bit and the operand n is shown in Figure 11.

X	Y	digit No.															
		15	14	13	12	11	10	9	8	7	6	5	4	3	2	1	0
0	0																MR0
1	1																MR1
2	2															MR2	
3	3															MR3	
4-7*	4	MR15	MR14	MR13	MR12	MR11	MR10	MR9	MR8	MR7	MR6	MR5	MR4				

↑  
file No.

\* The file 4 is selected when X register has any value among 4 to 7.

Figure 10 RAM Address Space

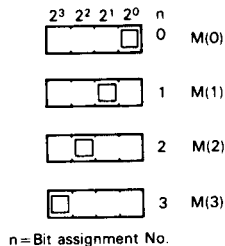

Figure 11 RAM Bit and Operand n

■ **REGISTER**

The HMCS43C has four 4-bit registers, two 3-bit registers and two 1-bit registers available to the programmer. The 1-bit registers are the Carry F/F and the Status F/F. They are explained in the following paragraphs.

● **Status F/F (S)**

The Status F/F latches the result of logical or arithmetic operations (Not Zero, Overflow) and bit test operations. The Status F/F affects conditional instructions (LPU, BR and CAL instructions). These instructions are executed only when the Status F/F is "1". If it is "0", these instructions are skipped and the Status F/F becomes "1".

● **Accumulator (A; A Register) and Carry F/F (C)**

The result of the Arithmetic Logic Unit (ALU) operation (4 bits) and the overflow of the ALU are loaded into the accumulator and the Carry F/F respectively. The Carry F/F can be set, reset or tested. Combination of the accumulator and the Carry F/F can be right or left rotated. The accumulator is the main register for ALU operation and the Carry F/F is used to store the overflow generated by ALU operation when the calculation of two or more digits (4 bits/digit) is performed.

● **B Register (B)**

The result of ALU operation (4 bits) is loaded into this register. The B register is used as a sub-accumulator to stack data temporarily and also used as a counter.

● **X Register (X)**

The result of ALU operation (3 bits) is loaded into this register. The X register is exchangeable with the SPX register and addresses the RAM file and is composed of 3-bit (0 to 7) register.

● **SPX Register (SPX)**

The SPX register is exchangeable with the X register.

The SPX register is used to stack the contents of the X register and expand the addressing system of RAM in combination with the X register. It is composed of 3-bit (0 to 7) register.

● **Y Register (Y)**

The result of ALU operation (4 bits) is loaded into this register. The Y register is exchangeable with the SPY register. The Y register can calculate itself simultaneously with transferring data by the bus lines, which is usable for the calculation of two or more digits (4 bits/digit). The Y register addresses the RAM digits and 1-bit Discrete I/Os.

● **SPY Register (SPY)**

The SPY register is exchangeable with the Y register. The SPY register is used to stack the contents of the Y register and expand the addressing system of RAM and 1-bit Discrete I/O in combination with the Y register.

■ **INPUT/OUTPUT**

● **4-bit Data Input/Output Channel (R)**

The HMCS43C has one 4-bit Data I/O Common Channel (R1) and one 4-bit Data Input Channel (R0) and two 4-bit Data Output Channels (R2, R3).

The 4-bit registers (Data I/O Register) are attached to R1, R2 and R3 channels.

Each channel is directly addressed by the operand p of input/output instruction.

The data is transferred from the accumulator and the B register to the Data I/O Registers R0 to R3 via the bus lines. ROM bit patterns are loaded into the Data I/O Registers R2 and R3 by the pattern instruction.

The input instruction inputs the 4-bit data into the accumulator and the B register through R1. Note that, since the Data I/O Register output is directly connected to the pin even during execution of input instruction, the input data is wired logic of the Data I/O Register output and the pin input.

Therefore, the Data I/O Register should be set to 15 (all bits of the Data I/O Register is "1") not to affect the pin input before execution of input instruction.

The block diagram is shown in Figure 12. The I/O timing is shown in Figure 13.

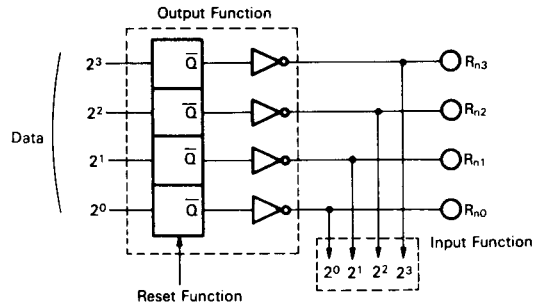

Figure 12 4-bit Data I/O Block Diagram

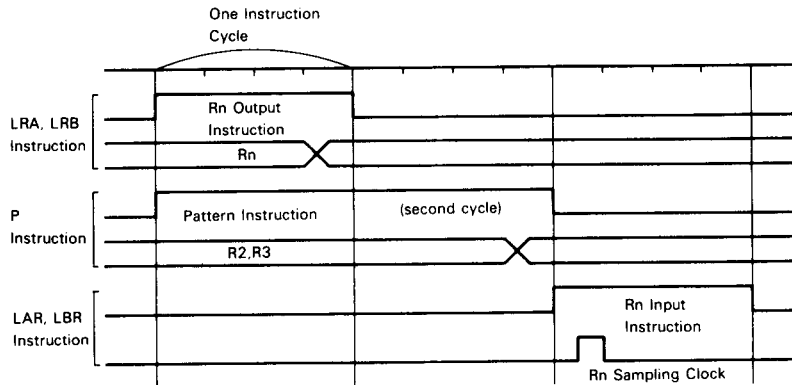

Figure 13 4-bit Data I/O Timing

● **1-bit Discrete Input/Output Common Pin (D)**

The HMCS43C has four 1-bit Discrete I/O Common Pins and twelve 1-bit Discrete Output Pins.

The 1-bit Discrete I/O is addressed by the Y register. The addressed latch can be set or reset by output instruction and level ("0" or "1") of the addressed pin can be tested by an input instruction.

Note that, since the latch output is directly connected to the

pin even during execution of input instruction, the input data is wired logic of the latch output and the pin input. Therefore, the latch should be set to "1" not to affect the pin input before execution of input instruction.

The D<sub>0</sub> to D<sub>3</sub> pins are also addressed directly by the operand n of input/output instruction and can be set or reset.

The block diagram is shown in Figure 14 and the I/O timing is in Figure 15.

**I/O Configuration**

The I/O configuration of each pin can be specified among Open Drain and With Pull up MOS using a mask option as shown in Figure 16.

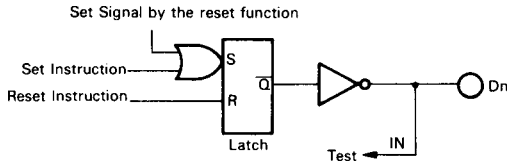

Figure 14 1-bit Discrete I/O Block Diagram

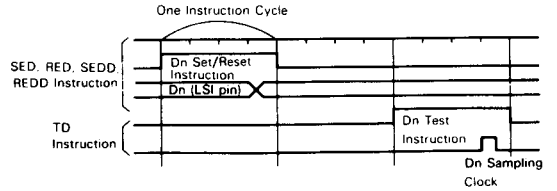
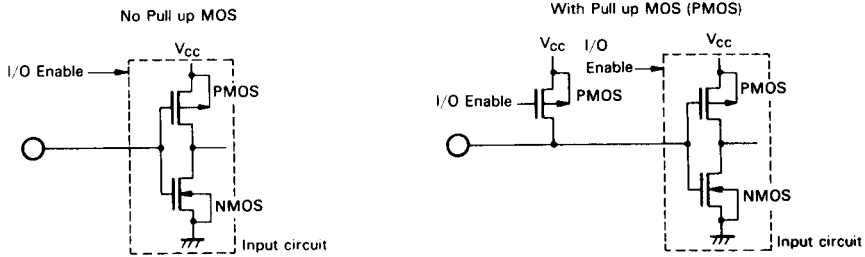

Figure 15 1-bit Discrete I/O Timing

**(a) Configuration of Input Pin**

Applied Pins : R<sub>00</sub> to R<sub>03</sub>, INT<sub>0</sub>, INT<sub>1</sub>



**(b) Configuration of Output Pin**

Applied Pins : D<sub>4</sub> to D<sub>15</sub>, R<sub>20</sub> to R<sub>23</sub>, R<sub>30</sub> to R<sub>33</sub>

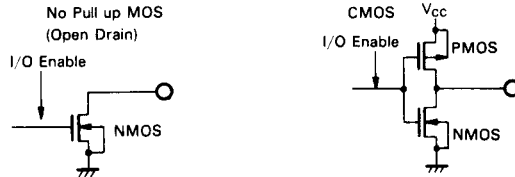

**(c) Configuration of I/O Pin**

Applied Pins : D<sub>0</sub> to D<sub>3</sub>, R<sub>10</sub> to R<sub>13</sub>

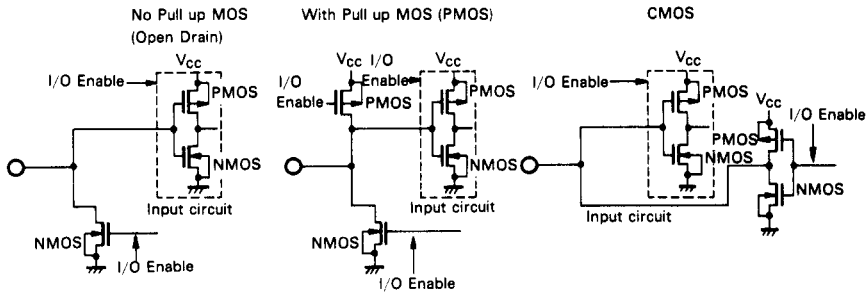

\*In "Data Hold" mode, the I/O Enable signal shown in the figure turns off the input circuit, Pull up MOS and NMOS output and sets CMOS output to high impedance (PMOS, NMOS : OFF).

Figure 16 I/O Configuration



■ **TIMER/COUNTER**

The timer/counter consists of 4-bit counter and 6-bit prescaler as shown in Figure 17.

The counter operates in the Timer Mode or Counter Mode according to the counting object. In the timer mode it counts overflow output pulse from the prescaler, and in the Counter Mode it counts INT<sub>1</sub> input pulse (counts leading edge), and increments to 15. Mode selection is determined according to the state of the CF. When the counter reaches zero (returns from 15), overflow output pulse is generated and the counter continues to count (14 → 15 → 0 → 1 → ...).

The relation between the specified value of the counter and specified time in the Timer Mode is shown in Table 3.

The prescaler is a 6-bit frequency divider. It generates 100/64 kHz pulses by dividing the system clock by 64. The prescaler is cleared when the data is loaded into the 4-bit counter by LTA, LTI instructions. The frequency division is 0 when the prescaler is cleared. At the 64th clock, an overflow output pulse is generated from the prescaler. During operation of the LSI, the prescaler operates and cannot be stopped.

The CF is the flip-flop (F/F) which controls the counter input. When the CF F/F is "1", input pulse of INT<sub>1</sub> is input to the counter (Counter Mode). When the CF is "0", prescaler overflow output pulse is input to the counter (Timer Mode).

The TF is the flip-flop (F/F) which masks the interrupt request from the timer/counter. It is set, reset and tested by instructions. If the overflow output pulse of the counter is generated when the TF F/F is "0", an interrupt request occurs and the TF F/F becomes "1". If the overflow output pulse is generated when the TF F/F is "1", no interrupt request occurs. So it can be used as timer/counter interrupt mask.

The pulse width of INT<sub>1</sub> in the Counter Mode should be two or more cycles both at "High" and "Low" levels as shown in Figure 18.

■ **INTERRUPT**

The HMCS43C can be interrupted in two different ways: through the external interrupt input pins (INT<sub>0</sub>, INT<sub>1</sub>) and the timer/counter interrupt request. When any interrupt occurs, processing is suspended, the Status F/F is unchanged, the contents of the present program counter is pushed onto the stack ST1 and

the contents of the stacks ST1 and ST2 are pushed onto the stacks ST2 and ST3 respectively. At that time, the Interrupt Enable F/F (I/E) is set and the address jumps to a fixed destination (Interrupt Address), and then the interrupt routine is executed. Stacking the registers other than the program counter must be performed by the program. The interrupt routine must end with RTNI (Return Interrupt) instruction which sets the I/E F/F simultaneously with the RTN instruction.

The Interrupt Address:

Input Interrupt Address . . . . .  
Page 1 Address 3F

Timer/Counter Interrupt Address . . . . .  
Page 0 Address 3F

The input interrupt has priority over the timer/counter interrupt.

The INT<sub>0</sub> and INT<sub>1</sub> pins have interrupt request functions.

Each pin consists of a circuit which generates leading pulse and the interrupt mask F/F (IF0, IF1). An interrupt is enabled (unmasked) when the IF0 F/F or IF1 F/F is reset. When the INT<sub>0</sub> or INT<sub>1</sub> pin changes from "0" to "1" (from "Low" level to "High" level), a leading pulse is generated to produce an interrupt request. At the same time, the IF0 F/F or IF1 F/F is set. When the IF0 F/F or IF1 F/F is set, it is an interrupt mask for INT<sub>0</sub> or INT<sub>1</sub>. (If a leading pulse is generated, no interrupt request occurs.)

An interrupt request generated by the leading pulse is latched into the input interrupt request F/F (I/R1) on the input side. If the Interrupt Enable F/F (I/E) is "1" (Interrupt Enable State), an interrupt occurs immediately and the I/R1 F/F and the I/E F/F are reset. If the I/E F/F is "0" (Interrupt Disable State), the I/R1 F/F is held at "1" until the HMCS43C gets into the Interrupt Enable State.

The IF0 F/F, the IF1 F/F, the INT<sub>0</sub> pin and the INT<sub>1</sub> pin can be tested by interrupt instruction. Therefore, the INT<sub>0</sub> and the INT<sub>1</sub> can be used as additional input pins with latches.

The INT<sub>0</sub> pin and INT<sub>1</sub> pin can be provided with Pull up MOS using a mask option as shown in Figure 19.

An interrupt request from the timer/counter is latched into the timer interrupt request F/F (I/RT). The succeeding operations are the same as an interrupt from the input. Only the exception is that, since an interrupt from the input precedes a

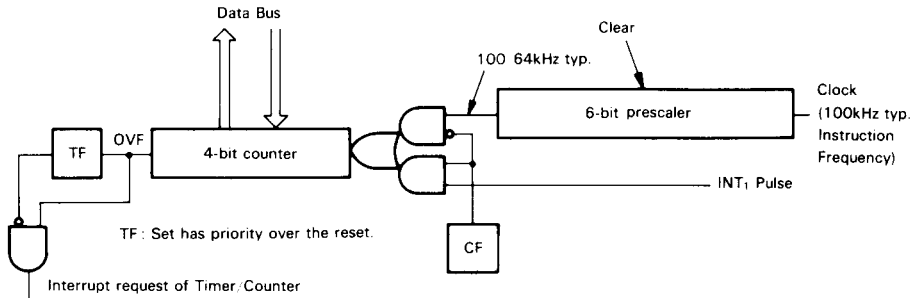

Figure 17 Timer/Counter Block Diagram

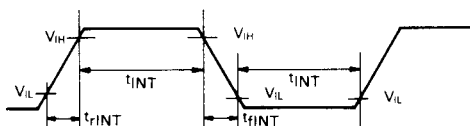

Figure 18 The Pulse Width of the INT<sub>1</sub> pin in the Counter Mode

timer/counter interrupt, the input interrupt occurs if both the I/R1 F/F and the I/RT F/F are "1" (when the input interrupt and the timer/counter interrupts are generated simultaneously). During this processing, the I/RT F/F remains "1". The timer/counter interrupt can be implemented after the input interrupt servicing is achieved.

The interrupt circuit block diagram is shown in Figure 20.

Table 3 Timer Range

Specified Value	Cycles	Time (ms)	Specified Value	Cycles	Time (ms)
0	1,024	10.24	8	512	5.12
1	960	9.60	9	448	4.48
2	896	8.96	10	384	3.84
3	832	8.32	11	320	3.20
4	768	7.68	12	256	2.56
5	704	7.04	13	192	1.92
6	640	6.40	14	128	1.28
7	576	5.76	15	64	0.64

[NOTE] Time is based on instruction frequency 100kHz. (one instruction cycle = 10μs)

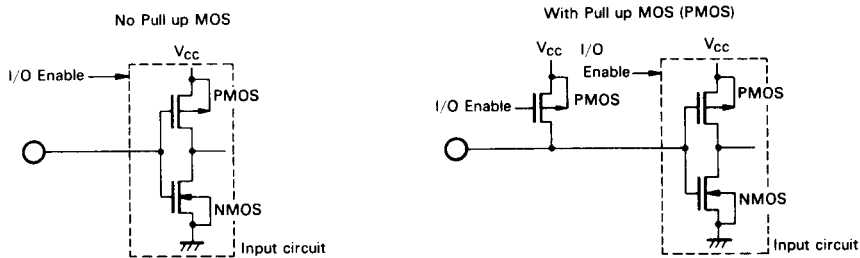

\*In "Data Hold" mode, the I/O Enable signal shown in the figure turns off the input circuit and Pull up MOS.

Figure 19 Configuration of INT<sub>0</sub> and INT<sub>1</sub>

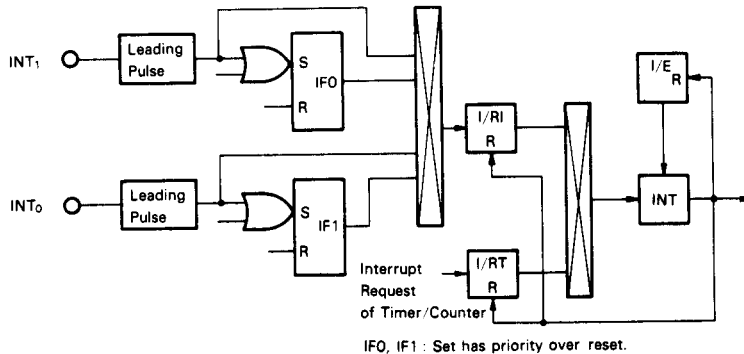

Figure 20 Interrupt Circuit Block Diagram

**■ RESET FUNCTION**

The reset is performed by setting the RESET pin to "1" ("High" level) and the HMCS43C gets into operation by setting it to "0" ("Low" level); Refer to Figure 21. Moreover, the HMCS43C has the automatic reset function (ACL; Built-in Reset Circuit). The Built-in Reset Circuit restricts the rise condition of the power supply; Refer to Figure 22. When the Built-in Reset Circuit is used, RESET should be connected to V<sub>SS</sub>.

Internal state of the HMCS43C is specified as follows by the

reset function.

- Program Counter (PC) is set to address 3F on page 15 (15-3F).
- I/RI, I/RT, I/E and CF are reset to "0".
- IF0, IF1 and TF are set to "1".
- I/O latch and registers (D<sub>0</sub> to D<sub>15</sub>, R1, R2, R3) are set to "1".

Note that other blocks (Status, Register, Timer/Counter, RAM, etc.) are not cleared.

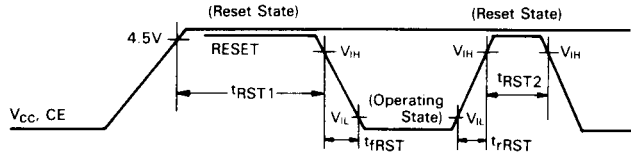

- $t_{RST1}$  includes the time required from the power ON until the operation gets into the constant state.
- $t_{RST2}$  is applied when the operation is in the constant state.

Figure 21 RESET Timing

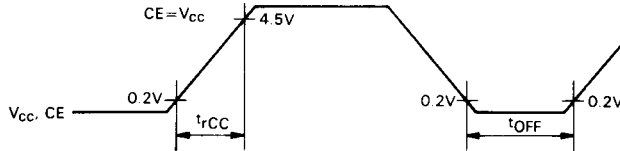

$t_{OFF}$  specifies the period when the power supply is OFF, when short break occurs and power supply ON/OFF is repeated.

Figure 22 Power Supply Timing for Built-in Reset Circuit

■ DATA HOLD FUNCTION

The Data Hold Function is the function to hold the data of RAM at low power dissipation. In the Data Hold Mode, all the data of RAM are held.

The power supply of logic parts except RAM becomes OFF automatically by the internal circuit of LSI when CE is set to "0" (Low) level. Then the data hold of RAM is performed at very low power dissipation. Outputs of output pins and I/O common

pins get into the high impedance state, that is, both PMOS and NMOS are OFF, and pull up MOS of input pins and I/O common pins are also OFF. Supply current doesn't increase even if the inputs are modified in the "Data Hold" mode, because the power supply of input circuit is OFF.

If reset state is not held when recovering from the Data Hold, the RAM data may be destructed.

The data hold timing is shown in Figure 23.

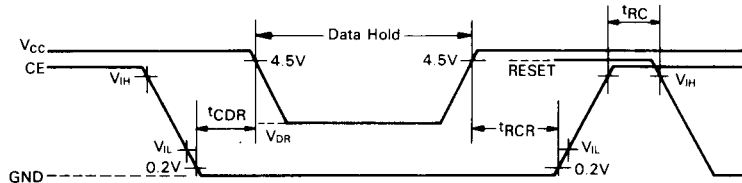

In recovering from Data Hold, RESET signal "1" (High) level input should be applied to RESET terminal to maintain reset state.

Figure 23 Data Hold Timing

■ OSCILLATOR

The HMCS43C contains its own on-board oscillator and clock circuit (Built-in CPG) requiring only an external timing control element. Also the HMCS43C can be provided an externally gen-

erated clock as a frequency source by an external oscillator (External CPG).

The user can select one clock operation mode using a mask option as shown in Figure 24.



(a) Internal Clock Operation Using Resistor R<sub>f</sub>

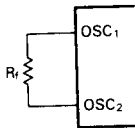

Wiring of OSC<sub>1</sub> and OSC<sub>2</sub> pins should be as short as possible because the oscillation frequency is modified by capacitance of this wiring.

(b) Internal Clock Operation Using Ceramic Filter Circuit (Built-in CPG ; Ceramic Filter Oscillator)  
(This is not applied to HMCS43CL)

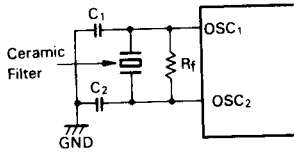

Ceramic Filter : CSB400P (MURATA)  
R<sub>f</sub> : 1MΩ ± 10%  
C<sub>1</sub> : 120pF ± 10% (ceramic capacitor)  
C<sub>2</sub> : 470pF ± 10% (ceramic capacitor)

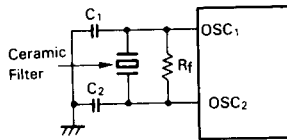

Ceramic Filter : KBR-400B (Kyocera)  
R<sub>f</sub> : 1MΩ ± 10%  
C<sub>1</sub> : 330pF ± 10% (ceramic capacitor)  
C<sub>2</sub> : 330pF ± 10% (ceramic capacitor)

This circuit is the example of the typical use. As the oscillation characteristics is not guaranteed, please consider and examine the circuit constants carefully on your application.

(c) External Clock Operation (External CPG)

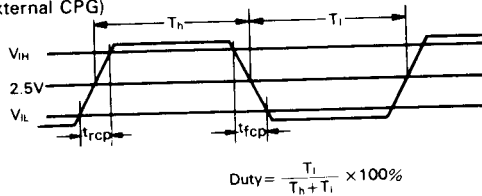
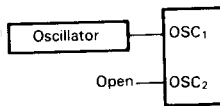

Figure 24 Clock Operation Mode

www.DataSheet4U.com

■ INSTRUCTION LIST

The instructions of the HMCS43C are listed according to their functions, as shown in Table 4.

Table 4 Instruction List

Group	Mnemonic	Function	Status
Register · Register Instruction	LAB	$B \rightarrow A$	
	LBA	$A \rightarrow B$	
	LAY	$Y \rightarrow A$	
	LASPX	$SPX \rightarrow A$	
	LASPY	$SPY \rightarrow A$	
	XAMR m	$A \leftrightarrow MR(m)$	
RAM Address Register Instruction	LXA	$A \rightarrow X$	
	LYA	$A \rightarrow Y$	
	LXI i	$i \rightarrow X$	
	LYI i	$i \rightarrow Y$	
	IY	$Y+1 \rightarrow Y$	NZ
	DY	$Y-1 \rightarrow Y$	NB
	AYY	$Y+A \rightarrow Y$	C
	SYX	$Y-A \rightarrow Y$	NB
	XSPX	$X \rightarrow SPX$	
	XSPY	$Y \rightarrow SPY$	
	XSPXY	$X \rightarrow SPX, Y \rightarrow SPY$	
RAM · Register Instruction	LAM (XY)	$M \rightarrow A (XY \leftrightarrow SPXY)$	
	LBM (XY)	$M \rightarrow B (XY \leftrightarrow SPXY)$	
	XMA (XY)	$M \rightarrow A (XY \leftrightarrow SPXY)$	
	XMB (XY)	$M \rightarrow B (XY \leftrightarrow SPXY)$	
	LMAIY (X)	$A \rightarrow M, Y+1 \rightarrow Y (X \leftrightarrow SPX)$	NZ
	LMADY (X)	$A \rightarrow M, Y-1 \rightarrow Y (X \leftrightarrow SPX)$	NB
Immediate Transfer Instruction	LMIIY i	$i \rightarrow M, Y+1 \rightarrow Y$	NZ
	LAI i	$i \rightarrow A$	
	LBI i	$i \rightarrow B$	
Arithmetic Instruction	AI i	$A+i \rightarrow A$	C
	IB	$B+1 \rightarrow B$	NZ
	DB	$B-1 \rightarrow B$	NB
	AMC	$M+A+C (F/F) \rightarrow A$	C
	SMC	$M-A-\bar{C} (F/F) \rightarrow A$	NB
	AM	$M+A \rightarrow A$	C
	DAA	Decimal Adjustment (Addition)	
	DAS	Decimal Adjustment (Subtraction)	
	NEGA	$\bar{A}+1 \rightarrow A$	
	COMB	$\bar{B} \rightarrow B$	
	SEC	"1" $\rightarrow C (F/F)$	
	REC	"0" $\rightarrow C (F/F)$	
	TC	Test C (F/F)	C (F/F)
	ROTL	Rotation Left	
	ROTR	Rotation Right	
	OR	$A \cup B \rightarrow A$	

(to be continued)



Group	Mnemonic	Function	Status
Compare Instruction	MNEI i	$M \neq i$	NZ
	YNEI i	$Y \neq i$	NZ
	ANEM	$A \neq M$	NZ
	BNEM	$B \neq M$	NZ
	ALEI i	$A \leq i$	NB
	ALEM	$A \leq M$	NB
	BLEM	$B \leq M$	NB
RAM Bit Manipulation Instruction	SEM n	"1" $\rightarrow$ M (n)	M (n)
	REM n	"0" $\rightarrow$ M (n)	
	TM n	Test M (n)	
ROM Address Instruction	BR a	Branch on Status 1	1
	CAL a	Subroutine Jump on Status 1	1
	LPU u	Load Program Counter Upper on Status 1	
	TBR p	Table Branch	
	RTN	Return from Subroutine	
Interrupt Instruction	SEIE	"1" $\rightarrow$ I/E	INT <sub>0</sub> INT <sub>1</sub> IFO IF1 TF
	SEIFO	"1" $\rightarrow$ IFO	
	SEIF1	"1" $\rightarrow$ IF1	
	SETF	"1" $\rightarrow$ TF	
	SECF	"1" $\rightarrow$ CF	
	REIE	"0" $\rightarrow$ I/E	
	REIFO	"0" $\rightarrow$ IFO	
	REIF1	"0" $\rightarrow$ IF1	
	RETF	"0" $\rightarrow$ TF	
	RECF	"0" $\rightarrow$ CF	
	TIO	Test INT <sub>0</sub>	
	TI1	Test INT <sub>1</sub>	
	TIFO	Test IFO	
	TIF1	Test IF1	
	TTF	Test TF	
	LTI i	i $\rightarrow$ Timer/Counter	
LTA	A $\rightarrow$ Timer/Counter		
LAT	Timer/Counter $\rightarrow$ A		
RTNI	Return Interrupt		
Input/Output Instruction	SED	"1" $\rightarrow$ D (Y)	D (Y)
	RED	"0" $\rightarrow$ D (Y)	
	TD	Test D (Y)	
	SEDD n	"1" $\rightarrow$ D (n)	
	REDD n	"0" $\rightarrow$ D (n)	
	LAR p	R(p) $\rightarrow$ A	
	LBR p	R(p) $\rightarrow$ B	
	LRA p	A $\rightarrow$ R(p)	
	LRB p	B $\rightarrow$ R(p)	
P p	Pattern Generation		
	NOP	No Operation	

[NOTE] 1. (XY) after a mnemonic code has four meanings as follows.

	Mnemonic only	Instruction execution only
	Mnemonic with X	After instruction execution, X → SPX
	Mnemonic with Y	After instruction execution, Y → SPY
	Mnemonic with XY	After instruction execution, X → SPX, Y → SPY
[Example]	LAM	M → A
	LAMX	M → A, X → SPX
	LAMY	M → A, Y → SPY
	LAMXY	M → A, X → SPX, Y → SPY

2. Status column shows the factor which brings the Status F/F "1" under judgement instruction or instruction accompanying the judgement.
- NZ ..... ALU Not Zero  
 C ..... ALU Overflow in Addition, that is, Carry  
 NB ..... ALU Overflow in Subtraction, that is, No Borrow  
 Except above ..... Contents of the status column affects the Status F/F directly.
3. The Carry F/F (C(F/F)) is not always affected by executing the instruction which affects the Status F/F.  
 Instructions which affect the Carry F/F are eight as follows.
- |     |      |
|-----|------|
| AMC | SEC  |
| SMC | REC  |
| DAA | ROTL |
| DAS | ROTR |
4. All instructions except the pattern instruction (P) are executed in 1 cycle. The pattern instruction (P) is executed in 2 cycles.

HMCS43C Mask Option List

- 5V Operation : HMCS43C
- 3V Operation : HMCS43CL

☆ Mark "✓" in "□" for the selected spec.

Date	
Customer	
Dept.	
Name	
ROM CODE ID	
LSI Type Name (entered by Hitachi)	

(1) I/O Option

Pin Name	I/O	I/O Option			Remarks	Pin Name	I/O	I/O Option			Remarks
		A	B	C				A	B	C	
D <sub>0</sub>	I/O					R <sub>00</sub>	I				
D <sub>1</sub>	I/O					R <sub>01</sub>	I				
D <sub>2</sub>	I/O					R <sub>02</sub>	I				
D <sub>3</sub>	I/O					R <sub>03</sub>	I				
D <sub>4</sub>	O		/			R <sub>10</sub>	I/O				
D <sub>5</sub>	O		/			R <sub>11</sub>	I/O				
D <sub>6</sub>	O		/			R <sub>12</sub>	I/O				
D <sub>7</sub>	O		/			R <sub>13</sub>	I/O				
D <sub>8</sub>	O		/			R <sub>20</sub>	O		/		
D <sub>9</sub>	O		/			R <sub>21</sub>	O		/		
D <sub>10</sub>	O		/			R <sub>22</sub>	O		/		
D <sub>11</sub>	O		/			R <sub>23</sub>	O		/		
D <sub>12</sub>	O		/			R <sub>30</sub>	O		/		
D <sub>13</sub>	O		/			R <sub>31</sub>	O		/		
D <sub>14</sub>	O		/			R <sub>32</sub>	O		/		
D <sub>15</sub>	O		/			R <sub>33</sub>	O		/		
INT <sub>0</sub>	I			/							
INT <sub>1</sub>	I			/							

☆ Specify the I/O composition with a mark of "O" in the applicable composition column.  
 A: No pull up MOS      B: With pull up MOS      C: CMOS Output

(2) Package

Package
<input type="checkbox"/> DP-42
<input type="checkbox"/> DP-42S

☆ Mark "✓" in "□" for the selected package.

(3) Oscillator (CPG option)

CPG	5V Operation	3V Operation
Resistor	<input type="checkbox"/> R <sub>f</sub> =91kΩ ± 2%	<input type="checkbox"/> R <sub>f</sub> =180kΩ ± 2%
Ceramic Filter	<input type="checkbox"/> MURATA: CSB400P	/
	<input type="checkbox"/> TDK: FCR400K	/
	<input type="checkbox"/> Kyocera: KBR-400B	/
External Clock	<input type="checkbox"/> f <sub>cp</sub> =200k to 440kHz	<input type="checkbox"/> f <sub>cp</sub> =130k to 240kHz

☆ Mark "✓" in "□" for the selected oscillator.

