

VIDEO SWITCH WITH 8dB AMPLIFIER

GENERAL DESCRIPTION

The NJM2223 is an integrated bipolar video switch with 8dB amplifier which selects one video signal from three different composite video signals.

The NJM2223 has also function of superimposer and synchronous signal clipping and is suit to picture in picture configuration

PACKAGE OUTLINE

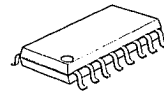

NJM2223M

FEATURES

- 12V operation.
- 3 input video signal.
- 2 output video signal.
- Switch operates with CMOS level.
- Super imposer function.
- Internal 8dB Amp.
- Package Outline
- Bipolar Technology

DMP16

PIN CONFIGURATION

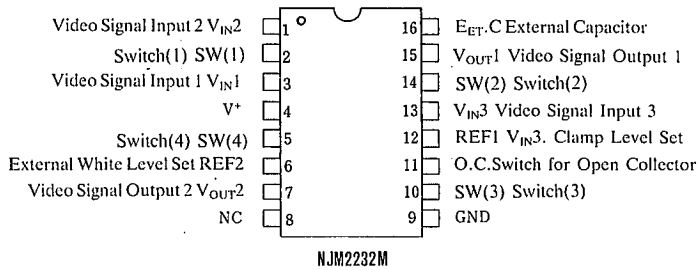

BLOCK DIAGRAM

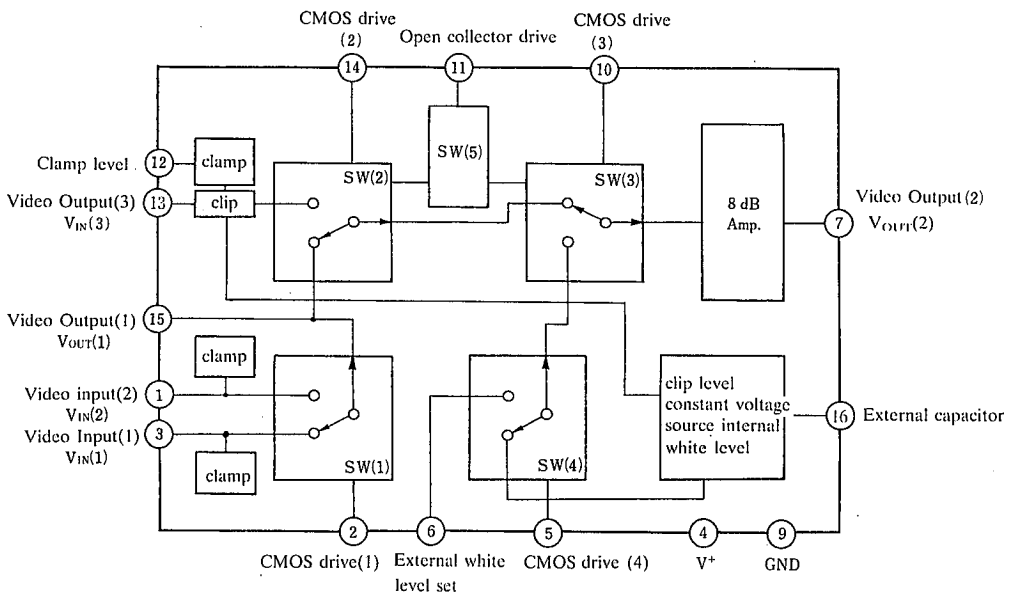

■ ABSOLUTE MAXIMUM RATINGS

(Ta=25°C)

PARAMETER	SYMBOL	RATINGS	UNIT
Supply Voltage	V*	15	V
Power Dissipation	P _D	(DMP16)350	mW
Operating Temperature Range	T _{opr}	-20~+75	°C
Storage Temperature Range	T _{slg}	-40~+125	°C

■ ELECTRICAL CHARACTERISTICS

(Ta=25°C, V*=12V)

PARAMETER	SYMBOL	TEST CONDITION	MIN.	TYP.	MAX.	UNIT
Operating Current	I _{CC}		—	14	19	mA
Voltage Gain (1)	G ₁	V _{IN} =1MHz, 1V _{p-p}	-1	0	1	dB
Voltage Gain (2)	G ₂	V _{IN} =1MHz, 1V _{p-p}	7	8	9	dB
Frequency Charact. (1)	G _{1,1}	G ₂ ': voltage gain at V _{IN} =1V _{p-p} , 5MHz 5MHz G _{2,2} =G ₂ '-G ₂	-1	0	1	dB
Frequency Charact. (2)	G _{2,2}	G ₁ ': voltage gain at V _{IN} =1V _{p-p} , 5MHz G _{1,1} =G ₁ '-G ₁	-1	0	1	dB
Differential Gain	DG	Stair Case, 1 V _{p-p}	—	—	3	%
Differential Phase	DP	Stair Case, 1V _{p-p}	—	—	3	deg
Threshold Level (1)	V _{TH-1}	SW (1) input	1.4	2.2	3.0	V
Threshold Level (2)	V _{TH-2}	SW (2) input	1.4	2.2	3.0	V
Threshold Level (3)	V _{TH-3}	SW (3) input	1.4	2.2	3.0	V
Threshold Level (4)	V _{TH-4}	SW (4) input	1.4	2.2	3.0	V
Threshold Level (5)	V _{TH-5}	Open collector input	0.5	1.0	2.0	V
Clipping Level	V _{CLIP}	SW (2) — ON V _{IN} (1) = 1V _{p-p} , stair case	32	40	48	IRE
Inside White Level	V _{IN}	SW (3) — ON V _{IN} (1)=1V _{p-p}	92	100	108	IRE
Cross-talk	CT	f _{IN} =4MHz	—	-50	—	dB

■ OUTPUT SELECT CODE

● Video Output (1)

SW (1)	V _{OUT} (1) Output Signal
0	V _{IN} (1)
1	V _{IN} (2)

● Video Output (2)

SW (1)	SW (2)	SW (3)	V _{OUT} (2) Output Signal
0	0	0	V _{IN} (1)
0	1	0	V _{IN} (3)
1	0	0	V _{IN} (2)
1	1	0	V _{IN} (2)

● Super Imposer

- Switching of SW (3), it imposes DC level in video signal regardless to SW (1), SW (2) Condition.

SW (3)	V _{OUT} (2) Output Signal
0	Video Signal
1	DC Level

- Switching of SW (4), it selects DC level at internal white level (100 IRE) or external setting level.

SW (4)	V _{OUT} (2) Output Signal
0	Internal White Level
1	External Set Level

● Open Collector Drive Switch

This switch has function to make SW (2), SW (3) no working and V_{OUT} (2) output signal to the same output signal of V_{OUT} (1). It operates in CMOS level.

■ TERMINAL FUNCTION

PIN.	EQUIVALENT CCT	PIN.	EQUIVALENT CCT
1		9	—
V _{IN2}		GND	
2		10	
SW(1)		SW(3)	
3		11	
V _{IN1}		open. O.C.	
4	—	12	
V+		REF1	
5		13	
SW(4)		V _{IN3}	
6		14	
REF2		SW(2)	
7		15	
V _{OUT2}		V _{OUT1}	
8	—	16	
NC		E _{FT.C}	

■ TEST CIRCUIT

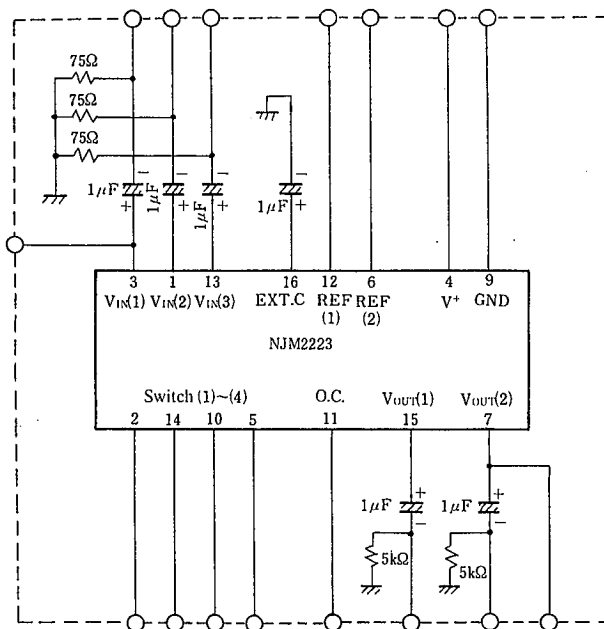

■ TYPICAL CHARACTERISTICS

Operating Current

($V^+ = 12V$)

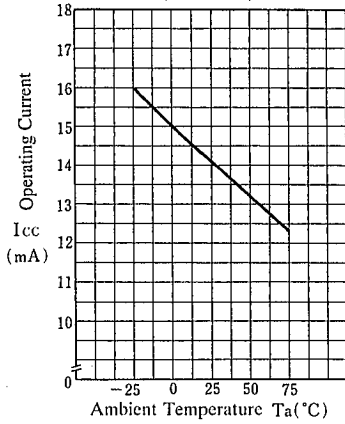

Clipping/Internal Level

($V^+ = 12V$)

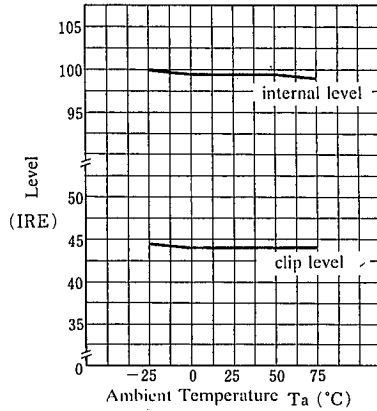

Voltage Gain (1),(2)

($V^+ = 12V$, $V_{IN(1)} : 1V_{P-P}$ 1MHz)

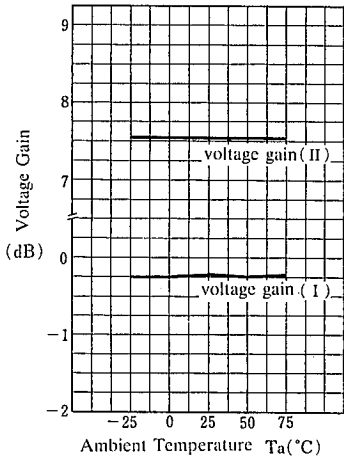

Gain Change Ratio (5MHz/1MHz)

($V^+ = 12V$, $V_{out(1)}/V_{out(2)}$ Gain deviation)

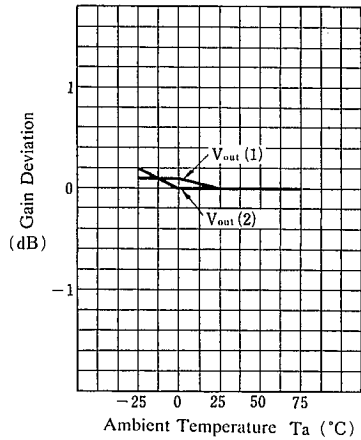

Differential Gain/Differential Phase

($V^+ = 12V$, $V_{IN(1)} : 1V_{P-P}$ standard signal)

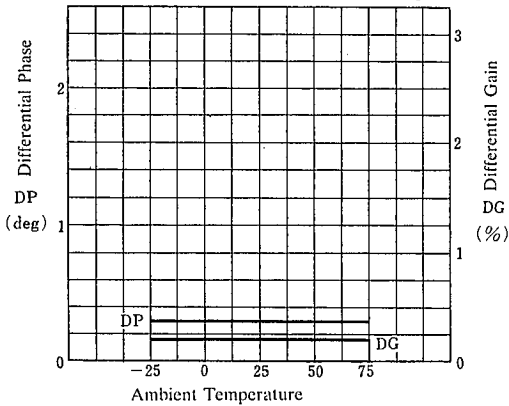

Threshold Level

($V^+ = 12V$)

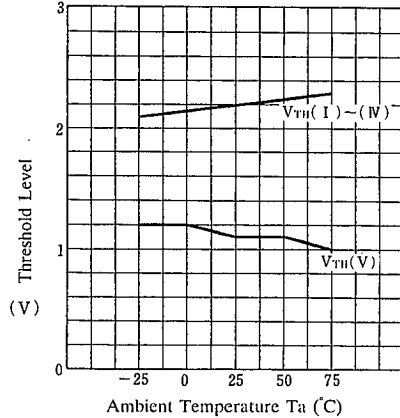

MEMO

[CAUTION]

The specifications on this databook are only given for information, without any guarantee as regards either mistakes or omissions. The application circuits in this databook are described only to show representative usages of the product and not intended for the guarantee or permission of any right including the industrial rights.