

INTEGRATED CONNECTOR MODULES

0863-2X8R-54 Gigabit Ethernet MagJack® 2 x 8 with LEDs

BI-COLOR LED POLARITY		
PIN	GREEN	ORANGE
11	-	+
12	+	-

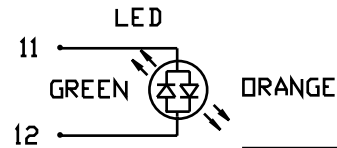

ELECTRICAL CHARACTERISTICS @ 25°C

TRANSFORMER TURNS RATIO

TP1	1CT : 1CT ±2%
TP2	1CT : 1CT ±2%
TP3	1CT : 1CT ±2%
TP4	1CT : 1CT ±2%

OPEN CIRCUIT INDUCTANCE @ 100kHz/100mVRMS 8mA DC BIAS

350 µH MIN.

INSERTION LOSS

0.1MHz TO 1MHz	-1.1 dB MAX
1MHz TO 65MHz	-0.5 dB MAX
65MHz TO 100MHz	-0.8 dB MAX
100MHz TO 125MHz	-1.2 dB MAX

RETURN LOSS (MIN)

0.5MHz-40MHz	-18 dB
40MHz-100MHz	-12+20LOG(f/80MHz) dB

CROSS TALK REJECTION (CM TO CM)

100kHz - 100MHz	-30 dB MIN
-----------------	------------

CROSS TALK REJECTION (CM TO DM)

100kHz - 100MHz	-35 dB MIN
-----------------	------------

HIPOT (Isolation Voltage):

1500 Vrms

LED

VF (FORWARD VOLTAGE)	IF=20mA	GREEN	2.2V TYP.
		PURE ORANGE	2.0V TYP.
λD (DOMINANT WAVELENGTH)	IF=20mA	GREEN	565nm TYP.
		PURE ORANGE	610nm TYP.

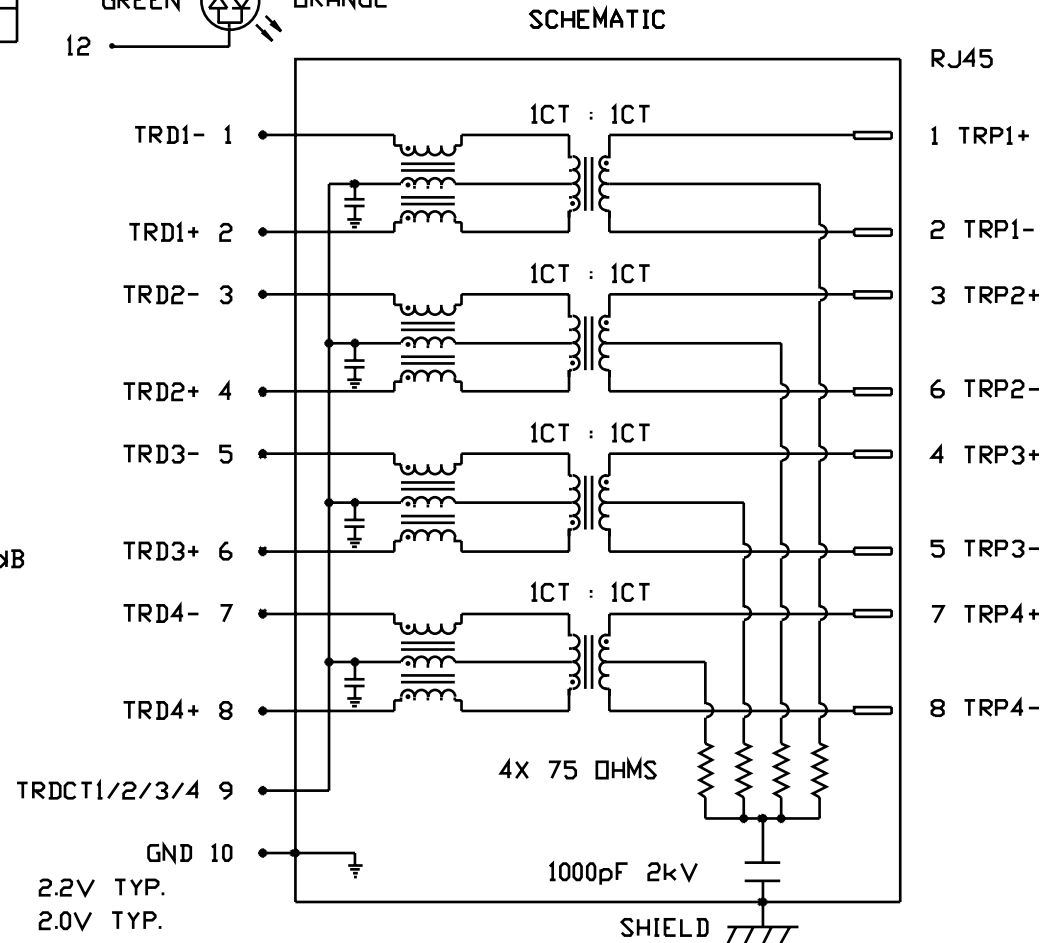

INTEGRATED CONNECTOR MODULES

0863-2X8R-54 Gigabit Ethernet MagJack® 2 x 8 with LEDs

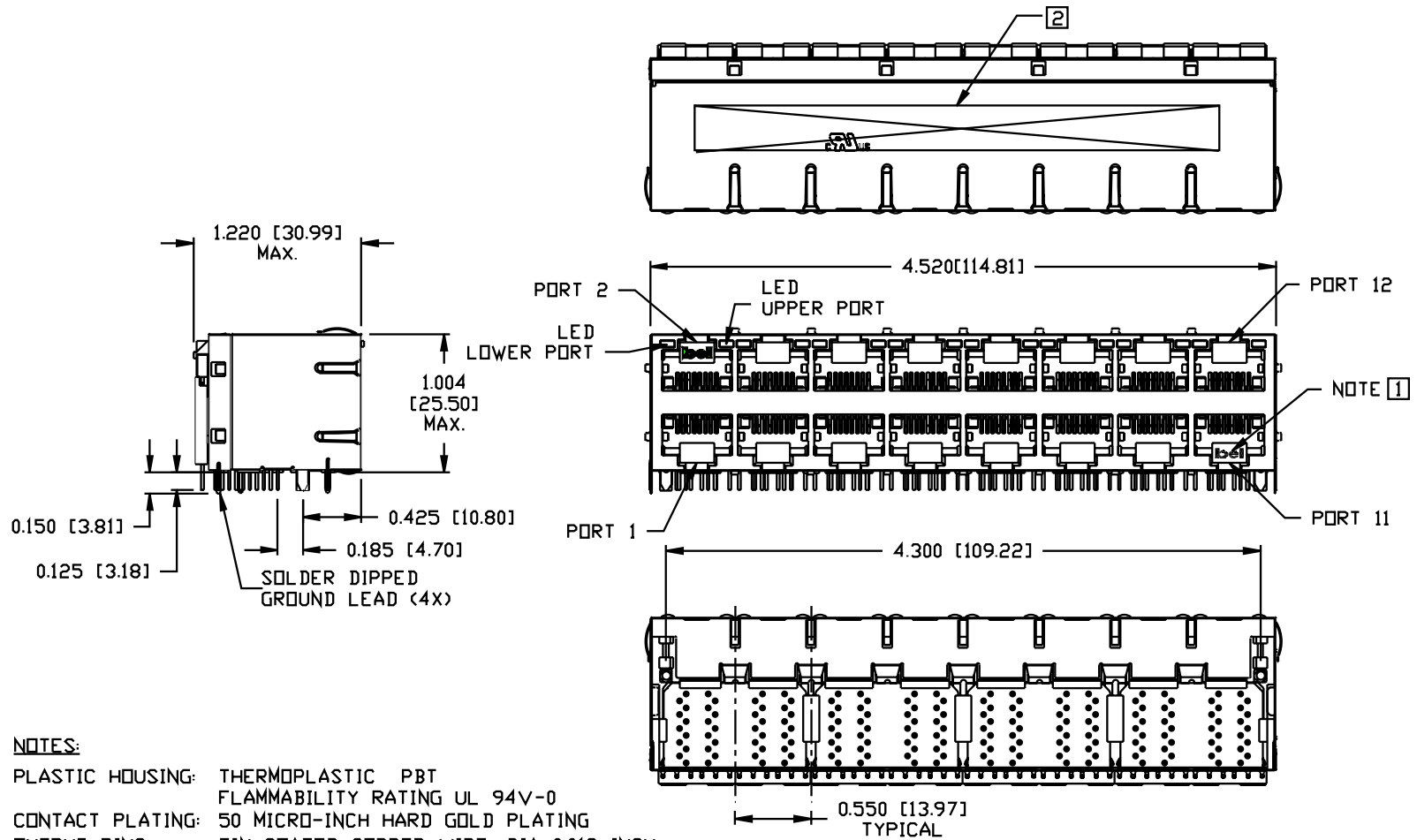

NOTES:

PLASTIC HOUSING: THERMOPLASTIC PBT
FLAMMABILITY RATING UL 94V-0

CONTACT PLATING: 50 MICRO-INCH HARD GOLD PLATING

OUTPUT PINS: TIN-COATED COPPER WIRE, DIA 0.018 INCH.

SOLDERABILITY: PER MIL STD. 202, METHOD 208.

METAL SHIELD: NICKEL PLATED COPPER ALLOY.
(ALL GROUND LEADS ARE SOLDER DIPPED)

1. JACK CAVITY CONFORMS TO FCC RULES AND REGULATIONS, PART 68 SUBPART F.
2. MARK PART WITH MFG LOGO, NAME, PART NUMBER AND DATE CODE.
- UL RECOGNIZED - FILE #E196366 AND E169987.

INTEGRATED CONNECTOR MODULES

0863-2X8R-54 Gigabit Ethernet MagJack® 2 x 8 with LEDs

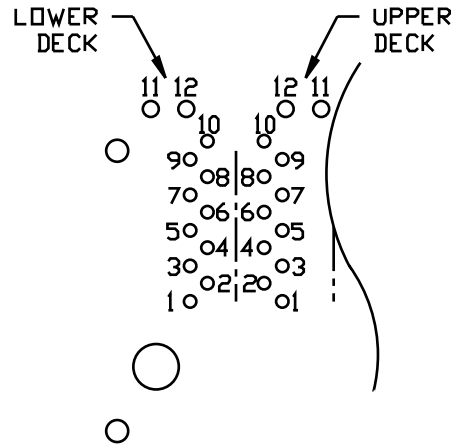

PIN-OUT INFORMATION
(COMPONENT SIDE VIEW)

12	GRN (+)/ORG (-)
11	GRN (-)/ORG (+)
10	GND
9	TRCT1/2/3/4
8	TRD 4+
7	TRD 4-
6	TRD 3+
5	TRD 3-
4	TRD 2+
3	TRD 2-
2	TRD 1+
1	TRD 1-

PORT ASSIGNMENT
(COMPONENT SIDE VIEW)

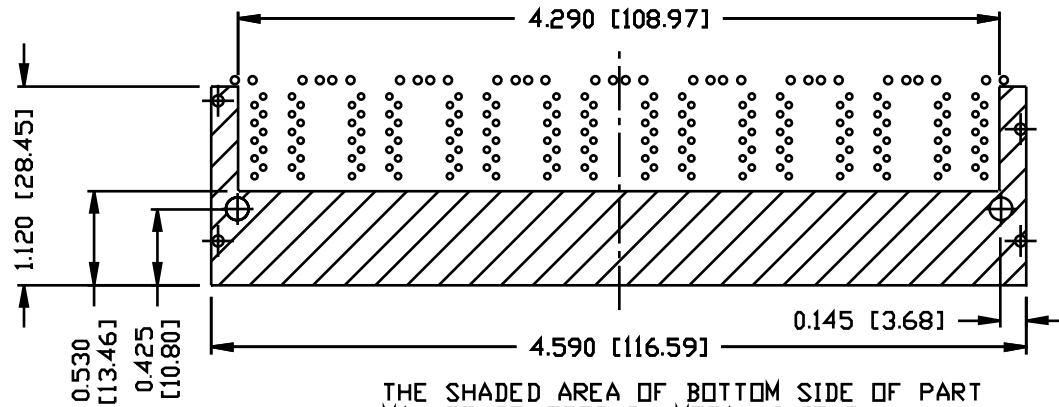
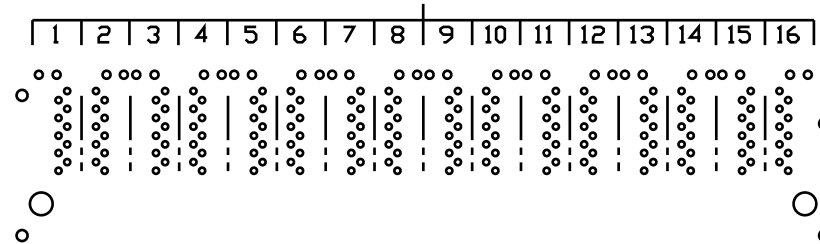

THE SHADED AREA OF BOTTOM SIDE OF PART
MAY BE COVERED BY METAL SHIELD.

INTEGRATED CONNECTOR MODULES

0863-2X8R-54 Gigabit Ethernet MagJack® 2 x 8 with LEDs

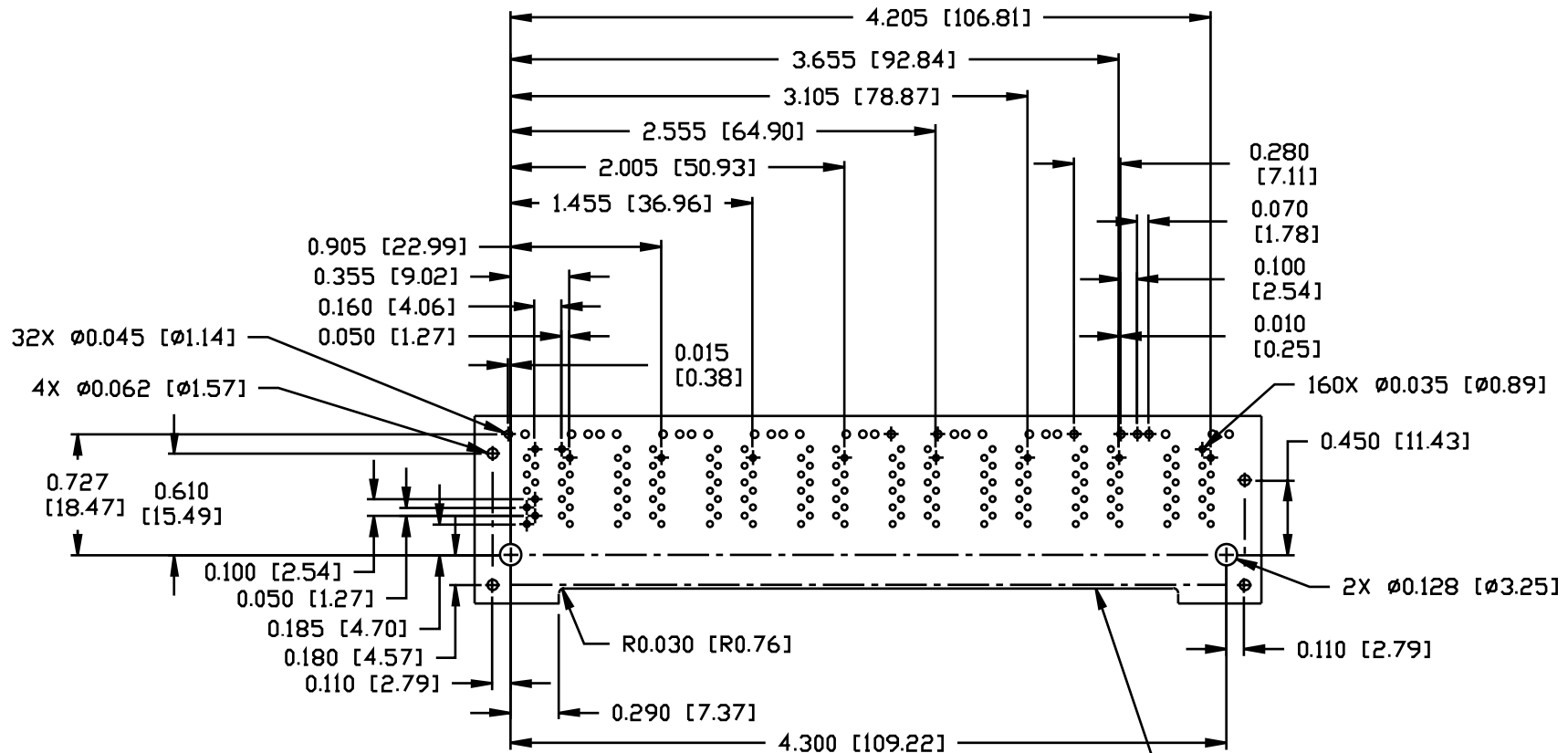

Recommended PCB front edge cutout. The bottom shield ground tabs (front) should not be seated on the top of the PCB.

SUGGESTED FOOTPRINT
(COMPONENT SIDE VIEW)

INTEGRATED CONNECTOR MODULES
0863-2X8R-54 Gigabit Ethernet MagJack® 2 x 8 with LEDs

SUGGESTED PANEL OPENING

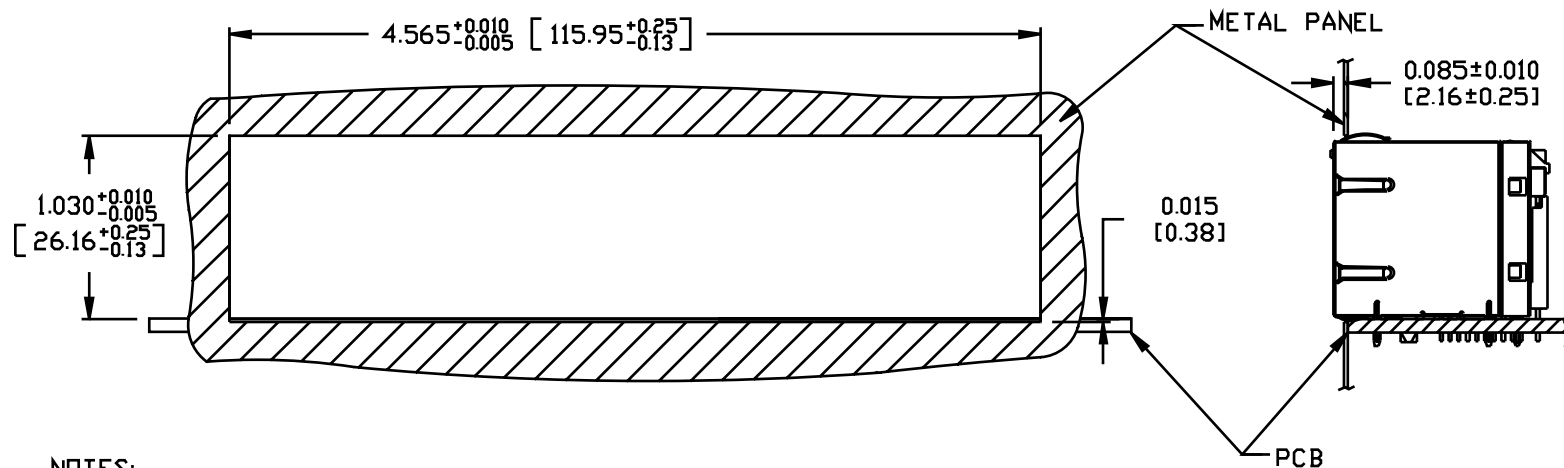

NOTES:

THE DISTANCE OF PANEL INSIDE SURFACE RELATIVE TO FRONT SURFACE OF PART IS ONLY A SUGGESTION. IN CASE THIS DISTANCE IS DIFFERENT, THE REQUIRED PANEL OPENING DIMENSIONS CHANGE ACCORDINGLY.

PACKING INFORMATION

PACKING TRAY : 0200-9999-B2 (TOP)
 0200-9999-B3 (BOTTOM)

PACKING QUANTITY : 10 PCS FINISHED GOODS PER TRAY
 7 TRAY (70 PCS FINISHED GOODS) PER CARTON BOX

NOTE : CARDBOARDS ARE PLACED BETWEEN LAYERS OF PACKING TRAY INSIDE CARTON BOX
 (INCLUDE THE UPPERMOST AND LOWERMOST TRAY)