

## Features

- Maximum Supply Voltage 40V
- One Programmable/Adjustable Boost Converter
- Two Programmable Buck Converters
- One Programmable Linear Regulator
- OTP Customer Mode
- 16-bit Serial Interface
- Two ISO9141 Interfaces (One Interface Programmable to LIN Functionality)
- Watchdog
- Various Diagnosis Functions
- 5 Voltage Sources Tailored to Resistor Measurement
- Charge Pump
- Small, 44-pin Package
- ESD Protection Against 2kV and 4kV

## 1. Description

With the introduction of the ATA6264, Atmel® introduces a new generation of airbag power supplies for future airbag systems tailored to the needs of the automotive industry. It is designed in Atmel's 0.8 micron BCDMOS technology. ATA6264 contains all the necessary blocks to supply the microcontroller, the firing capacitors, and peripheral components of the airbag system. The power supply specifically fulfills the power requirements of dual-voltage microcontrollers used in modern ECUs. The integrated watchdog and diagnosis blocks additionally support the safety aspects. The 8-MHz 16-bit SPI enables a high communication speed. Despite the high-level functionality, ATA6264 comes in a space-saving QFP44 package.



## Airbag Power Supply IC

**ATA6264**

**Preliminary**



Figure 1-1. Block Diagram

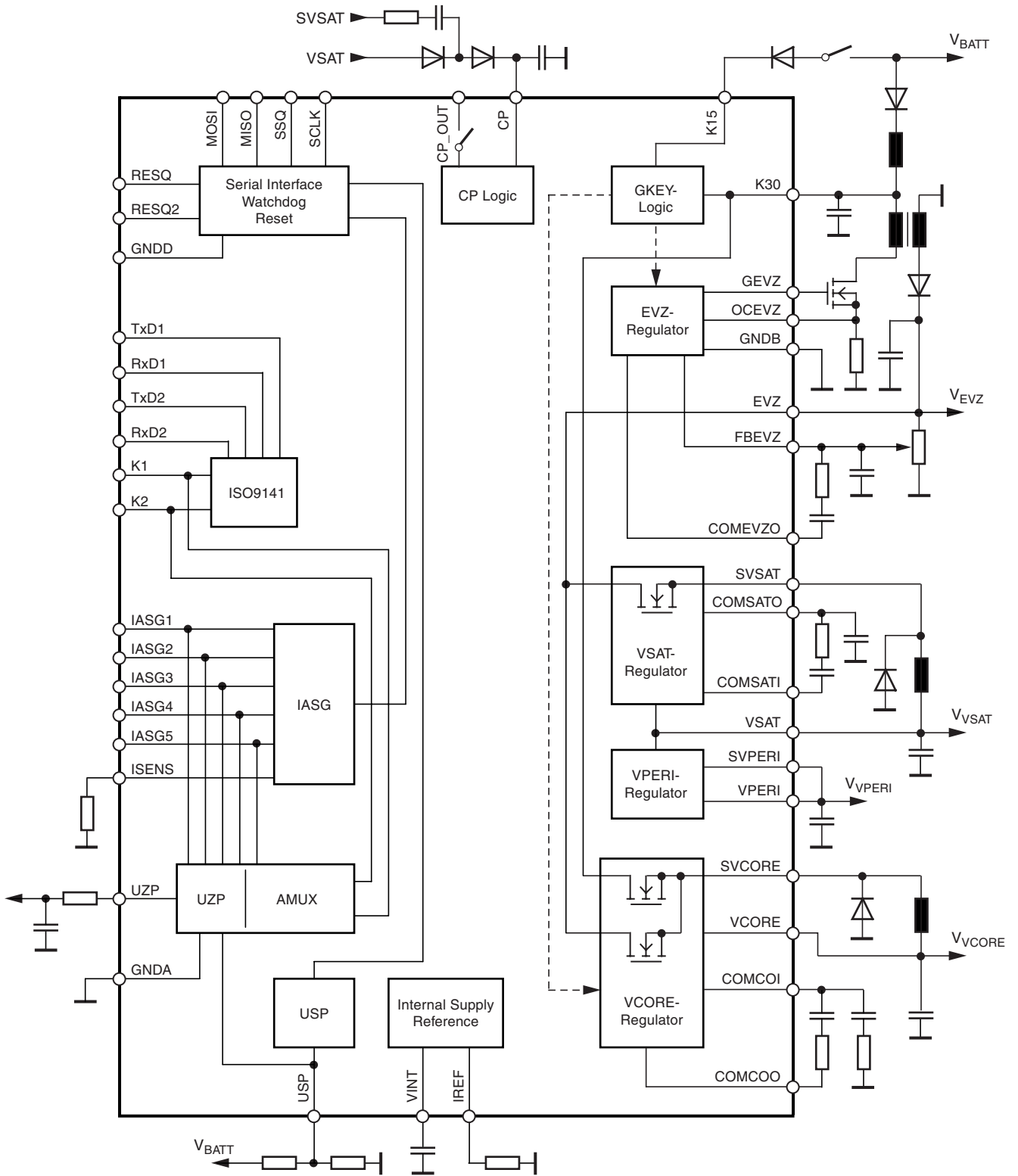

## 1.1 Block Description

### 1.1.1 Integrated Boost Converter EVZ

With an external n-channel FET, the integrated boost converter EVZ provides 3 different voltages adjustable via the serial interface for the energy reserve and firing capacitors. Two voltages are fixed values; one voltage can be adjusted using an external resistive divider.

### 1.1.2 Integrated Buck Converter VSAT

The integrated buck converter VSAT is a fully integrated step-down converter supplied by the boost converter, EVZ, and providing 7.8V, 9.1V, or 10.4V. The user can program the voltage via an OTP system.

### 1.1.3 Integrated Buck Converter VCORE

The integrated buck converter VCORE is a fully integrated step-down converter supplied either by the boost converter, EVZ, or by the battery, and providing 1.88V, 2.5V, or 5V. The user can program the voltage via an OTP system.

### 1.1.4 Linear Regulator VPERI

The linear regulator, VPERI, is supplied from the buck converter VSAT and provides an accurate voltage of  $3.3V \pm 3\%$  or  $5V \pm 4\%$  as a supply for sensitive elements such as sensors and ADC references with the current capability of 100 mA. The user can program the voltage via an OTP system. With a sophisticated power-sequencing concept of VCORE and VPERI, ATA6264 supports dual-voltage-supply microcontrollers, so that under all conditions the voltage difference between the two linear regulator voltages never drops below a defined value. This measure guarantees the safe operation of the system.

### 1.1.5 Blocks Included

- A general purpose comparator USP, for, for example, low battery voltage detection
- A band gap as reference for all internal voltages and currents
- Two ISO9141 interfaces, one of which is configurable via OTP in accordance with the LIN specification
- Five constant voltage sources with current-to-voltage mirrors used for resistance measurements, such as buckle switch detection in the range from  $-0.5$  mA to  $-40$  mA
- An AMUX block with push-pull buffer stage provides the output of all analog values such as voltage sources, low voltage detection, or the chip temperature for continuous diagnosis
- A 16-bit serial interface for the communication with the microcontroller which includes a 16-bit shift register, a 16-bit latch, and a decoder-logic block
- A watchdog to monitor the microcontroller and to generate reset signals in the case of failure
- Internal oscillator generates internal clock signals
- GKEY function to control the main switch of the ECU via a logic signal

## 2. Pin Configuration

Figure 2-1. Pinning QFP44

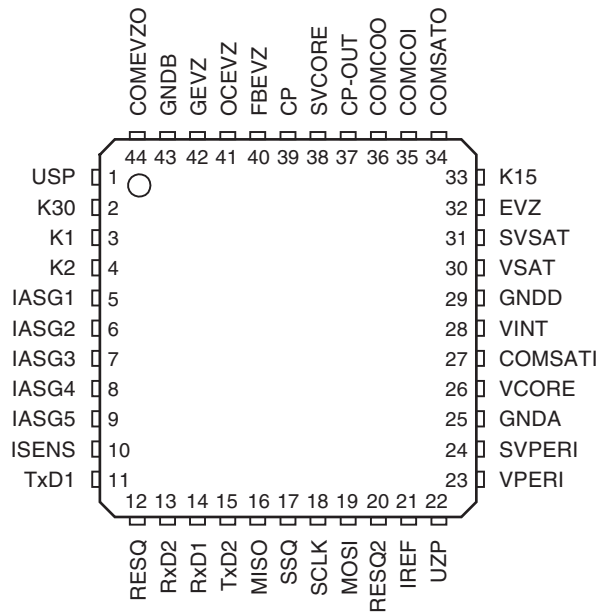

Table 2-1. Pin Description

| Pin | Symbol | Function  |
|-----|--------|---|
| 1   | USP    | Comparator input                                      |
| 2   | K30    | Continuous connection to the car battery              |
| 3   | K1     | Bus line of 1 <sup>st</sup> ISO9141 interface         |
| 4   | K2     | Bus line of 2 <sup>nd</sup> ISO9141 interface         |
| 5   | IASG1  | Output of voltage source 1                            |
| 6   | IASG2  | Output of voltage source 2                            |
| 7   | IASG3  | Output of voltage source 3                            |
| 8   | IASG4  | Output of voltage source 4                            |
| 9   | IASG5  | Output of voltage source 5                            |
| 10  | ISENS  | Output of the current mirror from the IASGx interface |
| 11  | TXD1   | Data input of the 1 <sup>st</sup> ISO9141 interface   |
| 12  | RESQ   | Reset output  |
| 13  | RXD2   | Data output of the 2 <sup>nd</sup> ISO9141 interface  |
| 14  | RXD1   | Data output of the 1 <sup>st</sup> ISO9141 interface  |
| 15  | TXD2   | Data input of the 2 <sup>nd</sup> ISO9141 interface   |
| 16  | MISO   | Data output of the serial interface                   |
| 17  | SSQ    | Chip select of the serial interface                   |
| 18  | SCLK   | Clock input of the serial interface                   |
| 19  | MOSI   | Data input of the serial interface                    |
| 20  | RESQ2  | Redundant reset output                                |
| 21  | IREF   | Connection for the external reference resistor        |
| 22  | UZP    | Analog measurement output                             |

Table 2-1. Pin Description

| Pin | Symbol   | Function   |
|-----|----------|--|
| 23  | VPERI    | Input for the VPERI regulator, internally used VPERI supply  |
| 24  | SVPERI   | Output of VPERI regulator power transistor                   |
| 25  | GND A    | Analog GND   |
| 26  | VCORE    | Input for VCORE regulator                                    |
| 27  | COMSAT I | Input of the VSAT externally compensated error amplifier     |
| 28  | VINT     | Output of internal supply voltage                            |
| 29  | GND D    | Digital GND  |
| 30  | VSAT     | Input for VSAT regulator, internally used VSAT supply        |
| 31  | SVSAT    | Output of VSAT regulator power transistor                    |
| 32  | EVZ      | Input for EVZ regulator, internally used EVZ supply          |
| 33  | K15      | Connection to car battery via the ignition key               |
| 34  | COMSAT O | Output of the VSAT externally compensated error amplifier    |
| 35  | COMCO I  | Input of the VCORE externally compensated error amplifier    |
| 36  | COMCO O  | Output of the VCORE externally compensated error amplifier   |
| 37  | CP-OUT   | Switchable output of charge pump voltage                     |
| 38  | SVCORE   | Output of VCORE regulator power transistor                   |
| 39  | CP       | Charge pump output   |
| 40  | FBEVZ    | Input for external resistor divider to adjust EVZ voltage    |
| 41  | OCEVZ    | Input for overcurrent measurement of the EVZ regulator       |
| 42  | GEVZ     | Gate driver output for the external FET of the EVZ regulator |
| 43  | GND B    | GND connection of all power stages                           |
| 44  | COMEVZ O | Output of the EVZ externally compensated error amplifier     |

### 3. Absolute Maximum Ratings

Stresses beyond those listed under “Absolute Maximum Ratings” may cause permanent damage to the device. This is a stress rating only and functional operation of the device at these or any other conditions beyond those indicated in the operational sections of this specification is not implied. Exposure to absolute maximum rating conditions for extended periods may affect device reliability. All voltages are referenced to an ideal ground level of an ECU connected to the GNDA, GNDB and GNDD pins.

| Parameters   | Remark   | Minimum  | Maximum | Unit       |
|--|--|--|---------|------------|
| Voltage at pins, connected directly or indirectly to the car battery (K30, K15, USP)   | Any combination of one or more pins applied with any voltage between the limits<br><br>K30 and K15 connected via diode to $V_{Batt}$<br>USP connected via minimum 5 k $\Omega$ to $V_{Batt}$ (maximum reverse current 5 mA). | -0.3   | +45     | V          |
| Voltage at pins, connected directly or indirectly to the car battery (K1, K2)  | Any combination of one or more pins applied with any voltage between the limits  | -25  | +45     | V          |
| Voltage at pins, connected directly or indirectly to the car battery (IASG1, IASG2, IASG3, IASG4, IASG5)   | Any combination of one or more pins applied with any voltage between the limits  | Voltage necessary to drive -40 mA stored in 20 $\mu$ H | 45      | V          |
| Voltage at ECU internal pins (FBEVZ, EVZ, VSAT)  | Any combination of one or more pins applied with any voltage between the limits  | -0.3   | +45     | V          |
| Maximum rate of change at pin VSAT   |  |  | 1       | V/ $\mu$ s |
| Voltage at ECU internal pins (SVSAT, SVCORE)   | Any combination of one or more pins applied with any voltage between the limits  | -1   | +45     | V          |
| Voltage at ECU internal pins (CP, CP-OUT)  | Any combination of one or more pins applied with any voltage between the limits  | -0.3   | +56     | V          |
| Voltage at ECU internal pins (GEVZ, OCEVZ)   | Any combination of one or more pins applied with any voltage between the limits  | -0.3   | +10     | V          |
| Voltage at ECU internal pins (COMEVZO, COMSATO, COMSATI, VPERI, SVPERI, VCORE, COMCOI, COMCOO, IREF, UZP, ISENS, RXD1, TXD1, RXD2, TXD2, RESQ, RESQ2, MISO, MOSI, SSQ, SCLK, VINT) | These voltages can be applied in any combination with any voltage between the limits   | -0.3   | +7      | V          |
| Current at logic pins  | Connected to voltages outside of maximum voltage ratings via resistor  | -3   | +3      | mA         |
| ESD classification at pins connected to devices outside the ECU (K30, K15)   |  |  |         |            |
| Human body model (HBM)   | HBM<br>AEC Q100-002  | $\pm$ 4000   |         | V          |

### 3. Absolute Maximum Ratings (Continued)

Stresses beyond those listed under “Absolute Maximum Ratings” may cause permanent damage to the device. This is a stress rating only and functional operation of the device at these or any other conditions beyond those indicated in the operational sections of this specification is not implied. Exposure to absolute maximum rating conditions for extended periods may affect device reliability. All voltages are referenced to an ideal ground level of an ECU connected to the GNDA, GNDB and GNDD pins.

| Parameters   | Remark                   | Minimum | Maximum | Unit |
|--|--------------------------|---------|---------|------|
| ESD classification at pins connected to devices outside the ECU (IASG1 to IASG5) |                          |         |         |      |
| Human body model (HBM)   | HBM<br>AEC Q100-002      | ±3000   |         | V    |
| ESD classification at pins connected to devices outside the ECU (K1 and K2)      |                          |         |         |      |
| Human body model (HBM)   | HBM<br>AEC Q100-002      | ±2500   |         | V    |
| General ESD classification for all other pins                                    |                          |         |         |      |
| Human body model (HBM)   | HBM<br>AEC Q100-002      | ±1500   |         | V    |
| Charged device model (CDM) – no corner pins                                      | CDM<br>ESD STM5.3.1-1999 | ±500    |         | V    |
| Charged device model (CDM) – corner pins   |                          | ±750    |         | V    |

## 4. Functional Range

Within the functional range, the ATA6264 works as specified. All voltages are referenced to the ideal ground level of an ECU connected to the GNDA, GNDB and GNDD pins.

At the beginning of each specification table, supply voltage and temperature conditions are described.

**Table 4-1.** Electrical Characteristics – Functional Range

| No.  | Parameters   | Test Conditions | Pin | Symbol | Min.  | Typ. | Max. | Unit | Type* |
|------|--|-----------------|-----|--------|---|------|------|------|-------|
| 1.1  | Voltage on pins K30, K15, USP  |                 |     |        | -0.3  |      | +40  | V    |       |
| 1.1a | Voltage on pins K1, K2   |                 |     |        | -25   |      | +40  | V    |       |
| 1.2  | Rate of supply voltage rise (K30, K15, K1, K2)   |                 |     |        |   |      | 50   | V/μs |       |
| 1.3  | Supply voltage EVZ   |                 |     |        | -0.3  |      | +40  | V    |       |
| 1.4  | Supply voltage VSAT  |                 |     |        | -0.3  |      | +14  | V    |       |
| 1.5  | Supply voltages VCORE, VPERI   |                 |     |        | -0.3  |      | +5.5 | V    |       |
| 1.6  | Supply voltage CP, CP-OUT  |                 |     |        | -0.3  |      | +50  | V    |       |
| 1.7  | Voltage on digital I/O pins  |                 |     |        | -0.3  |      | +5.5 | V    |       |
| 1.8  | Voltage on pins SVSAT, SVCORE  |                 |     |        | -1.0  |      | +40  | V    |       |
| 1.9  | Voltage on pins UZP, ISENS, COMCOI, COMCOO, COMSATO, COMSATI, COMEVZO, FBEVZ, IREF, VINT                   |                 |     |        | -0.3  |      | +5.5 | V    |       |
| 1.10 | Voltage on pins GEVZ, OCEVZ  |                 |     |        | -0.3  |      | +10  | V    |       |
| 1.11 | Voltage on pin SVPERI  |                 |     |        | -0.3  |      | +6   | V    |       |
| 1.12 | Voltage on pins IASGx (x = 1 to 5)   |                 |     |        | Voltage necessary to drive -40 mA stored in 20 μH |      | 40   | V    |       |
| 1.14 | Temperatures:  |                 |     |        |   |      |      |      |       |
|      | Operating ambient temperature range  |                 |     |        | -40   |      | +90  | °C   |       |
|      | Operating junction temperature range   |                 |     |        | -40   |      | +150 | °C   |       |
|      | Storage ambient/junction temperature range   |                 |     |        | -55   |      | +105 | °C   |       |
| 1.15 | Thermal resistance junction ambient  |                 |     |        |   |      | 60   | K/W  |       |
| 1.16 | Substrate current which can be drawn without disturbances to upper defined blocks/functions <sup>(1)</sup> |                 |     |        | -40   |      |      | mA   |       |

\*) Type means: A = 100% tested, B = 100% correlation tested, C = Characterized on samples, D = Design parameter

Note: 1. No substrate current occurs at pins K1, K2 down to  $V_{K1}, V_{K2} > -25V$



## 4.1 Protection Against Substrate Currents

Due to the fact that the ATA6264 is connected to the wiring harness and to components outside of the ECU, negative voltages at the following pins might occur:

- IASG interface: IASG1, IASG2, IASG3, IASG4, IASG5
- USP comparator: USP

If substrate currents occur, it is guaranteed by design that no disturbance and malfunction of the following blocks and functions will happen:

- No disturbance of RESET block.
- No voltage changes of any regulators outside of their tolerances.
- No impact on digital circuitry (for example, changes of latches, status register, etc.)
- No latch up of any circuitry

## 5. Supply Currents

A minimum current has to flow into each pin for proper functioning of the IC.

**Table 5-1.** Electrical Characteristics – Supply currents

| No.  | Parameters              | Test Conditions   | Pin   | Symbol      | Min.  | Typ. | Max. | Unit    | Type* |
|------|-------------------------|---|-------|-------------|-------|------|------|---------|-------|
| 2.1  | Supply current at K30   | <b>Standby mode:</b> $0V < V_{K30} = 18V$ ,<br>$V_{K15} = 3V$ and KEYLATCH = OFF  | K30   | $I_{K30}$   | 0     |      | 50   | $\mu A$ | A     |
| 2.1a | Supply current at K30   | <b>Standby mode:</b> $18V < V_{K30} = 40V$ ,<br>$V_{K15} = 3V$ and KEYLATCH = OFF   | K30   | $I_{K30}$   | 0     |      | 5    | mA      | A     |
| 2.1b | Supply current at K30   | <b>Startup mode:</b> $0V < V_{K30} = 18V$ ,<br>$V_{K15} > 4.15V$ or KEYLATCH = ON,<br>$V_{EVZ} = 0V$ , $C_{CP} = 47$ nF   | K30   | $I_{K30}$   | 0     |      | 7    | mA      | A     |
| 2.1c | Supply current at K30   | <b>Startup mode:</b> $18V < V_{K30} = 40V$<br>$V_{K15} > 4.15V$ or KEYLATCH = ON<br>$V_{EVZ} = 0V$ , $C_{CP} = 47$ nF   | K30   | $I_{K30}$   | 0     |      | 10   | mA      | A     |
| 2.1d | Supply current at K30   | <b>Normal mode:</b> $0V < V_{K30} = 18V$ ,<br>$V_{EVZ} > V_{K30}$ , $V_{K15} > 4V$ or<br>KEYLATCH = ON, SVCORE open,<br>AMUX Measurement K30 active   | K30   | $I_{K30}$   | 0     |      | 6.5  | mA      | A     |
| 2.1e | Supply current at K30   | <b>Normal mode:</b> $18V < V_{K30} = 40V$ ,<br>$V_{EVZ} > V_{K30}$ , $V_{K15} > 4.15V$ or<br>KEYLATCH = ON, SVCORE open,<br>AMUX Measurement K30 active   | K30   | $I_{K30}$   | 0     |      | 10   | mA      | A     |
| 2.2  | Supply current at EVZ   | <b>Startup mode:</b> $0V < V_{EVZ} = 40V$ ,<br>$V_{SAT} = V_{PERI} = V_{CORE} = 0V$ ,<br>$V_{K30} > 5V$ , $V_{K15} > 4.15V$ , SVCORE<br>and SVSAT open  | EVZ   | $I_{EVZ}$   | 0     |      | 5    | mA      | A     |
| 2.2a | Supply current at EVZ   | <b>Normal mode:</b> $0V < V_{EVZ} = 40V$ ,<br>$V_{PERI}$ and $V_{CORE} > \text{Reset}$<br>Threshold, $V_{EVZ} > V_{K30}$ ,<br>$V_{SAT} = 10V$ , $V_{K30} > 5V$ ,<br>$V_{K15} > 4.15V$ , SVCORE and<br>SVSAT open, AMUX Measurement<br>EVZ active        | EVZ   | $I_{EVZ}$   | 0     |      | 6    | mA      | A     |
| 2.2b | Supply current at EVZ   | <b>Autonomous mode:</b><br>$0V < V_{EVZ} = 40V$ , $V_{PERI}$ and $V_{CORE}$<br>$> \text{Reset Threshold}$ , $V_{EVZ} > V_{K30}$ ,<br>$V_{SAT} = 10V$ , $V_{K30} < 3.85V$ ,<br>$V_{K15} < 3V$ , SVCORE and SVSAT<br>open, AMUX Measurement EVZ<br>active | EVZ   | $I_{EVZ}$   | 0     |      | 10   | mA      | A     |
| 2.3  | Supply current at VSAT  | $0V < V_{SAT} = 14V$ , SVPERI open,<br>AMUX measurement VSAT active   | VSAT  | $I_{VSAT}$  | 0     |      | 1.5  | mA      | A     |
| 2.4  | Supply current at VPERI | $0V < V_{PERI} = 5.3V$ , AMUX<br>measurement VPERI active   | VPERI | $I_{VPERI}$ | -0.2  |      | 2.2  | mA      | A     |
| 2.5  | Supply current at VCORE | $0V < V_{CORE} = 5.3V$ , AMUX<br>measurement VCORE active   | VCORE | $I_{VCORE}$ | -0.45 |      | 1    | mA      | A     |

\*) Type means: A = 100% tested, B = 100% correlation tested, C = Characterized on samples, D = Design parameter

## 5.1 Discharger Circuit

Applications using the ATA6264 usually use a reverse polarity protection diode (D1 in Figure 5-1) in the power supply to prevent any damage if the wrong polarity is applied to  $V_{K30}$ . Unfortunately, this method includes some risk as can be seen in the following description:

During *Standby mode* ( $V_{K15} < 3V$  and KEYLATCH = OFF) the IC consumes only a low current,  $I_{K30}$ . Any peaks on the supply voltage ( $V_{Pulse}$  in Figure 5-1) will gradually charge the blocking capacitor (C1). D1 prevents the capacitor from being discharged via the power supply and the very small quiescent current via the IC can also be neglected. This means that during long periods of Standby mode, the IC's supply voltage could increase continuously until finally the maximum supply voltage limit would be exceeded and the IC could be damaged. ATA6264 therefore features a discharger circuit which avoids such unwanted effects. If  $V_{K30}$  exceeds a threshold value of approximately 26.8V, the blocking capacitor is discharged via an integrated resistor until  $V_{K30}$  again falls below the threshold.

Figure 5-1. Discharger Circuit

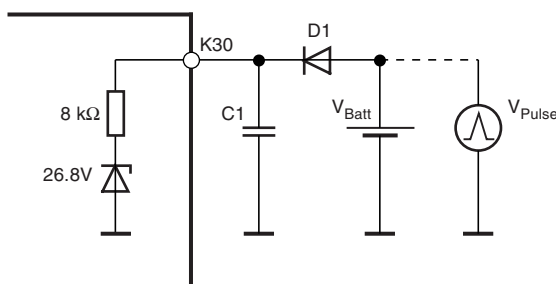

## 5.2 Initial Programming of the ATA6264

The ATA6264 supports different output voltages at the VSAT, VPERI and the VCORE regulators. In addition, different modes at the ISO9141 interfaces can be adjusted at the initial programming (IP). The memory cells are one-time programmable (OTP) and cannot be changed after the IP (default values are "0"). In general, the IP is done after mounting the ATA6264 on the PCB with an in-circuit tester. The programming voltage of 11.7V has to be applied on pin VSAT. It is also possible to use the VSAT regulator as the programming voltage because VSAT is programmed to 11.7V ( $\pm 0.5V$ ) as long as the Test mode is entered and the lock bit is not set. To ensure proper programming of the ATA6264, at least a 10- $\mu F$  electrolytic cap and a 100-nF ceramic cap have to be applied at pin VSAT.



The following settings can be made at the initial programming:

| MSBit |     |     |     |     |         | LSBit  |          |
|-------|-----|-----|-----|-----|---------|--------|----------|
| VR1   | VR2 | VR3 | VR4 | EXT | ISO/LIN | Parity | Lock bit |

**Table 5-2.** Initial Programming Settings

| VR1 | VR2 | VR3 | VR4 | VCORE                                | VPERI | VSAT  |
|-----|-----|-----|-----|--------------------------------------|-------|-------|
| 0   | 0   | 0   | 0   | All regulators deactivated (default) |       |       |
| 0   | 0   | 0   | 1   | 1.88V                                | 3.3V  | 7.8V  |
| 0   | 0   | 1   | 0   | 1.88V                                | 3.3V  | 9.1V  |
| 0   | 0   | 1   | 1   | 1.88V                                | 3.3V  | 10.4V |
| 0   | 1   | 0   | 0   | 2.5V                                 | 3.3V  | 7.8V  |
| 0   | 1   | 0   | 1   | 2.5V                                 | 3.3V  | 9.1V  |
| 0   | 1   | 1   | 0   | 2.5V                                 | 3.3V  | 10.4V |
| 0   | 1   | 1   | 1   | 1.88V                                | 5V    | 7.8V  |
| 1   | 0   | 0   | 0   | 1.88V                                | 5V    | 9.1V  |
| 1   | 0   | 0   | 1   | 1.88V                                | 5V    | 10.4V |
| 1   | 0   | 1   | 0   | 2.5V                                 | 5V    | 7.8V  |
| 1   | 0   | 1   | 1   | 2.5V                                 | 5V    | 9.1V  |
| 1   | 1   | 0   | 0   | 2.5V                                 | 5V    | 10.4V |
| 1   | 1   | 0   | 1   | 5V                                   | 5V    | 7.8V  |
| 1   | 1   | 1   | 0   | 5V                                   | 5V    | 9.1V  |
| 1   | 1   | 1   | 1   | 5V                                   | 5V    | 10.4V |

|            | Set to 0                                  | Set to 1                             |
|------------|---|--------------------------------------|
| <b>EXT</b> | No external transistor at VPERI (default) | External transistor at VPERI applied |

|                | Set to 0                                  | Set to 1                    |
|----------------|---|-----------------------------|
| <b>ISO/LIN</b> | ISO9141 mode is activated at K1 (default) | LIN mode is activated at K1 |

The IP data is valid only if the parity is odd. If the IP data is not valid, or if the lock bit is not set, the programming will not be executed.

**Figure 5-2.** Programming Sequence

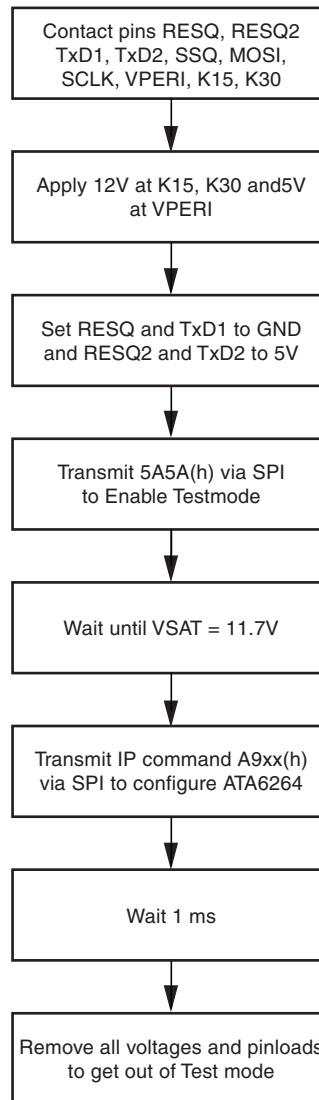

### 5.3 Start-up and Power-down Procedure

The ATA6264 is powered via the pin K30 (battery voltage) and via a diode or a resistor it is connected to the ignition key line K15. In order to detect an interruption on one of these pins correctly, resistors are implemented at these pins. Normally, the main supply pin of ATA6264 is pin K30. In the case of a missing or a too-low voltage at pin K30, the whole IC is supplied from the backup power supply capacitor hooked up to pin EVZ.

**Figure 5-3.** Block Diagram Start-up and Power-down Procedure

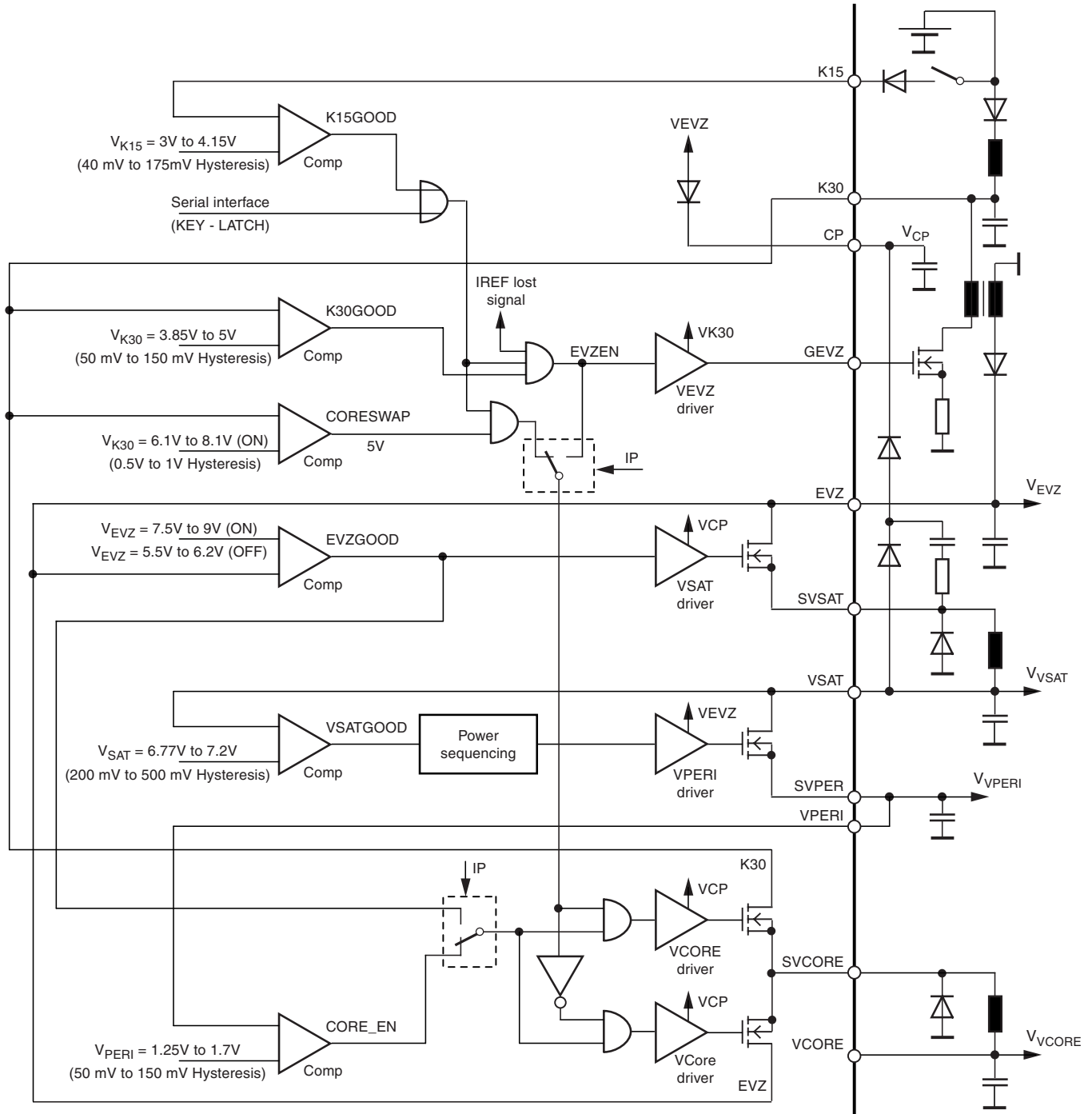

Depending on the initial programming of the ATA6264, the start-up procedure takes place in different phases.

### 5.3.1 Start-up Procedure if $V_{\text{VCORE}}$ is Programmed to Be 5V or 2.5V

**Phase1:** After switching on the ignition key, K15 voltage will apply at pin K15. If, in addition, the voltage at pin K30 is larger than 3.85V to 5V, the EVZ regulator will be enabled. The signal K15GOOD can be replaced by the serial interface command KEYLATCH which can be set via the serial interface.

**Phase2:** If  $V_{\text{EVZ}}$  is larger than 7.5V to 9V the VSAT regulator starts operating and the VCORE regulator will be enabled.

**Phase3:** After  $V_{\text{VSAT}}$  has reached 6.77V to 7.2V, the VPERI regulator starts working. The VCORE regulator starts operating depending on the charge pump voltage.

### 5.3.2 The Power-down Procedure Takes Place in Different Phases

**Phase1:** If the ignition key is switched off, K15 voltage will vanish at pin K15. If the serial interface command KEYLATCH is not set, the EVZ regulator stops working. The external charge pump is still working because EVZ is above VSAT and the VSAT regulator is not in *Permanent-on mode*. The charge-pump voltage still supplies the VSAT regulator and the VCORE regulator. Because the EVZ regulator stops working, VCORE will be switched to EVZ.

**Phase2:** The EVZ capacitor will be discharged, and as soon as the voltage at pin VSAT drops to low, the VSAT regulator will go into Permanent-on mode. If VSAT reaches Permanent-on mode, the external charge pump stops working and the VSAT voltage falls analog to the EVZ voltage. If the voltage at VSAT is below 6.27V to 7V, the VPERI regulator will be switched off. Depending on the charge-pump voltage, the VCORE regulator stops working.

**Phase3:** When the voltage at the EVZ capacitor gets to be lower than 5.5V to 6.2V, VSAT is switched off.

**Figure 5-4.** Start-Up and Power-Down Procedure if  $V_{V_{CORE}}$  Programmed to Be 5V or 2.5V

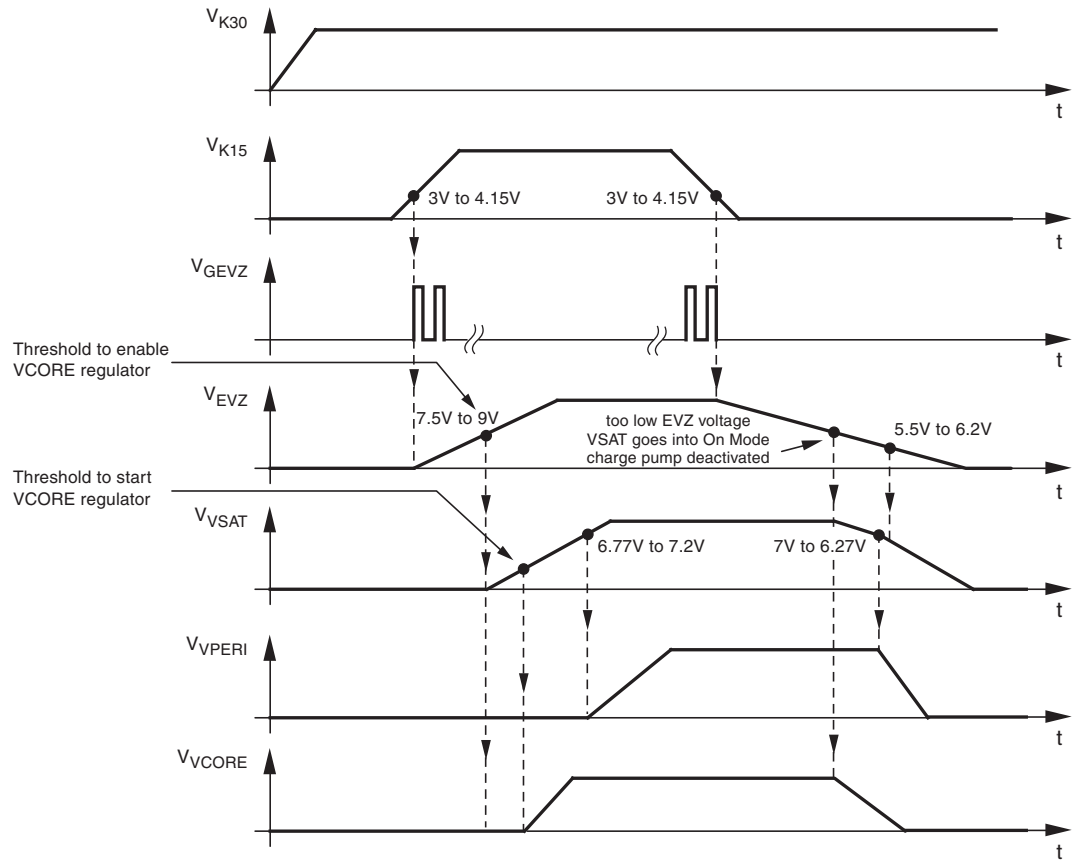

### 5.3.3 Start-up Procedure if $V_{V_{CORE}}$ Programmed to Be 1.88V

**Phase1:** After switching on the ignition key, the K15 voltage will appear at pin K15. If, in addition, the voltage at pin K30 is larger than 3.85V to 5V, the EVZ regulator will be enabled. The signal K15GOOD can be replaced by the serial interface command KEYLATCH which can be set by the serial interface.

**Phase2:** If  $V_{EVZ}$  is larger than 7.5V to 9V, the VSAT regulator starts operating.

**Phase3:** After  $V_{VSAT}$  has reached 6.77V to 7.2V, the VPERI regulator starts working.

**Phase4:** If  $V_{VPERI}$  is higher than 1.25V to 1.7V, the V\_CORE regulator will be enabled.



### 5.3.4 The Power-down Procedure for $V_{V_{CORE}}$ is Programmed to be 1.88V

**Phase1:** If the ignition key is switched off, the K15 voltage will vanish at pin K15. If the serial interface command KEYLATCH is not set, the EVZ regulator stops working. The external charge pump is still working because EVZ is above VSAT and the VSAT regulator is not in the Permanent-on mode. The charge-pump voltage still supplies the VSAT regulator and the VCORE regulator. Because the EVZ regulator stops working, VCORE will be switched to EVZ.

**Phase2:** The EVZ capacitor will be discharged, and as soon as the voltage at pin VSAT drops too low, the VSAT regulator will go into Permanent-on mode. If VSAT reaches Permanent-on mode, the external charge pump stops working and the VSAT voltage falls analog to the EVZ voltage. If the voltage at VSAT is below 6.27V to 7V, the VPERI regulator will be switched off. Depending on the charge-pump voltage, the VCORE regulator stops working. The power sequencing function for the VPERI regulator is still active and guarantees a maximum voltage difference between VPERI and VCORE of 2.8V

**Phase3:** After VVPERI becomes lower than 1.1V to 1.55V, the VCORE regulator has to stop working.

**Phase4:** When the voltage at the EVZ capacitor is lower than 5.5V to 6.2V, VSAT is switched off.

**Figure 5-5.** Start-up and Power-down Procedure if  $V_{V_{CORE}}$  Programmed to Be 1.88V

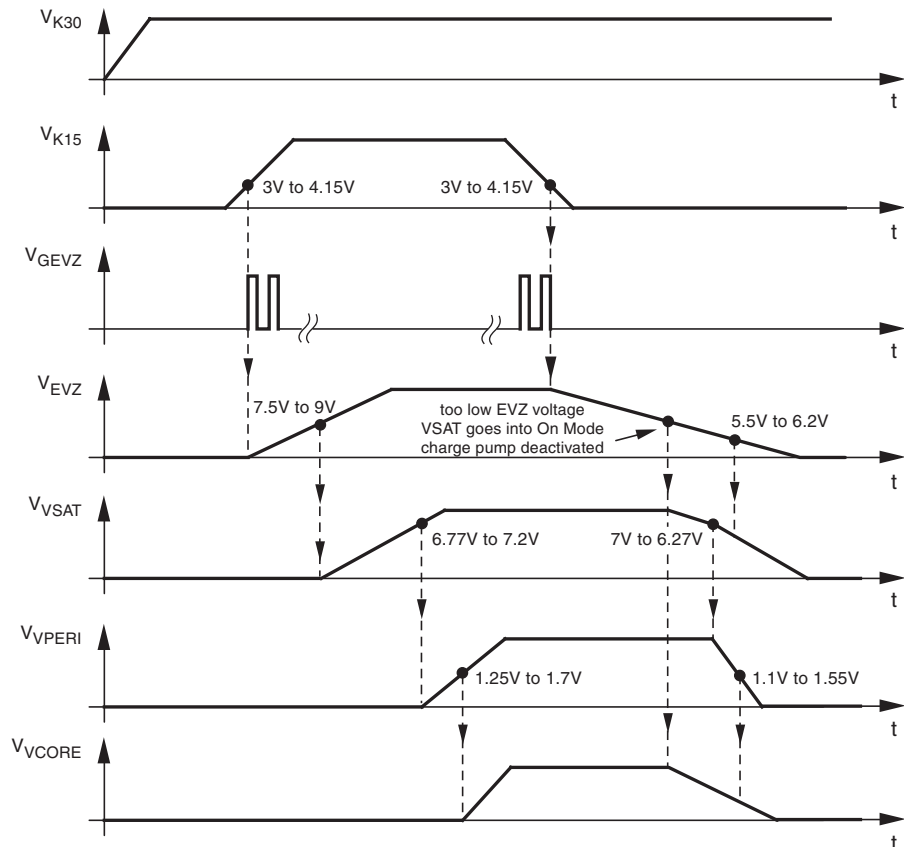

## 6. Power Supply Sequencing

(Only active when initial programming sets  $V_{V_{CORE}} = 1.88V$  and  $V_{V_{PERI}} = 3.3V$ )

In order to meet the requirements of several dual-voltage-supply microcontrollers, a power-sequencing function is implemented. The ATA6264 ensures that the voltage difference  $V_{PERI} - V_{CORE}$  will not exceed 2.8V.

The voltage difference between  $V_{PERI}$  and  $V_{CORE}$  is monitored. In error cases, for example, if the  $V_{CORE}$  regulator does not start to work, the difference may rise above the 2.8V threshold. In this case, the  $V_{PERI}$  regulator is switched off before reaching this level and switched on again if the voltage difference drops below a hysteresis value.

**Figure 6-1.** Example for Incorrect Ramp Up

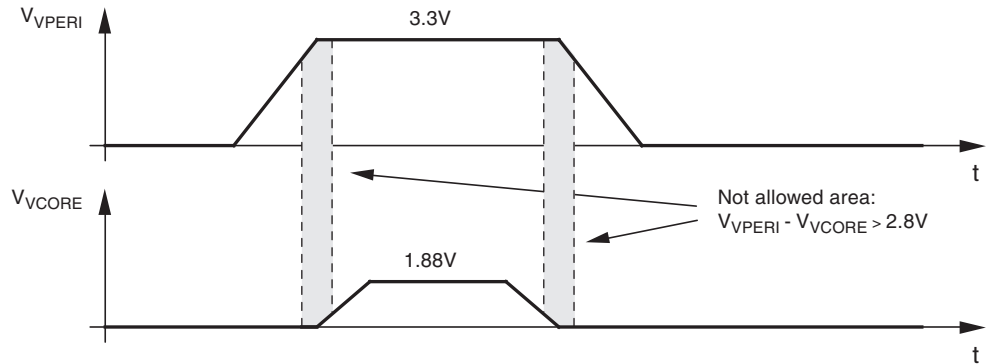

Necessary for operation:

$V_{EVZ} = 0V$  to 40V,  $V_{INT} = 3.7V$  to 5.47V

Operating conditions of all other supply pins:

$V_{K30}$ ,  $V_{VSAT}$ ,  $V_{V_{PERI}}$  and  $V_{V_{CORE}}$  are within functional range limits,  $T_j = -40^{\circ}C$  to  $150^{\circ}C$

Other pins:

As defined in [Section 4. "Functional Range" on page 8.](#)

**Table 6-1.** Electrical Characteristics – Power Supply Sequencing

| No.  | Parameters   | Test Conditions | Pin                        | Symbol                        | Min | Typ. | Max. | Unit | Type* |
|------|--|-----------------|----------------------------|-------------------------------|-----|------|------|------|-------|
| 5.1  | Maximum voltage difference<br>$V_{V_{PERI}} - V_{V_{CORE}}$                    |                 | $V_{PERI}$ ,<br>$V_{CORE}$ | $V_{V_{PERI}} - V_{V_{CORE}}$ | 0   |      | 2.8  | V    | A     |
| 5.2a | Voltage level $V_{V_{PERI}} - V_{V_{CORE}}$ to switch off $V_{PERI}$ regulator |                 | $V_{PERI}$ ,<br>$V_{CORE}$ | $V_{V_{PERI}} - V_{V_{CORE}}$ | 2.3 |      | 2.8  | V    | A     |
| 5.2b | Hysteresis for $V_{V_{PERI}} - V_{V_{CORE}}$ to enable $V_{PERI}$ regulator    |                 |                            | $V_{HYS}$                     |     |      | 100  | mV   | A     |

\*) Type means: A = 100% tested, B = 100% correlation tested, C = Characterized on samples, D = Design parameter

**Figure 6-2.** Block Diagram Power Supply Sequencing

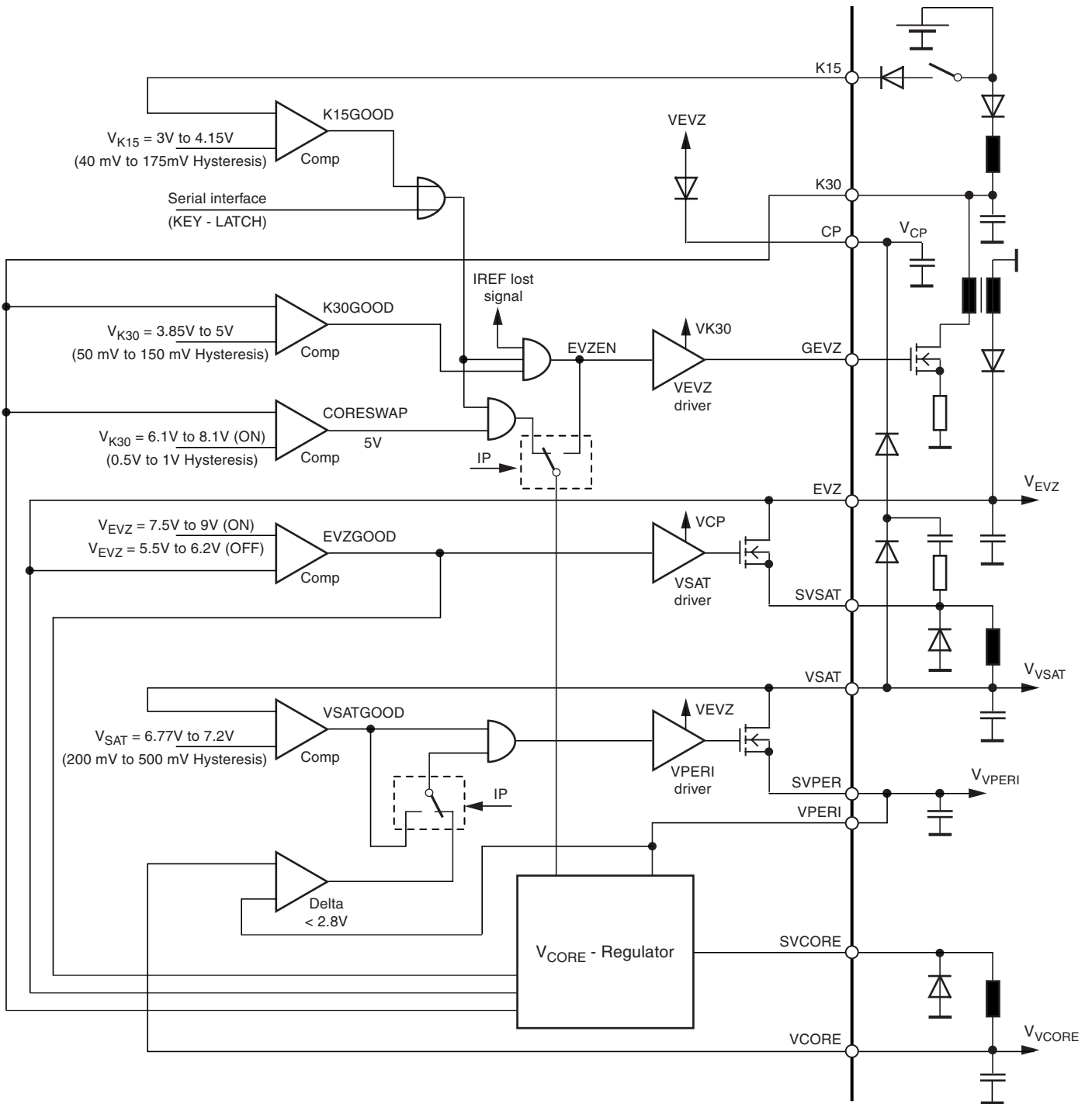

## 7. Charge Pump

To supply the VSAT and VCORE drivers, an external charge pump is provided. Both FETs<sup>(1)</sup> are driven by the high charge pump voltage  $V_{CP}$  to ensure that they can be switched to a low-ohmic state. For correct function of the charge pump, an external capacitor of  $C = 47 \text{ nF}$  has to be connected to pin SVSAT, and another of  $C = 100 \text{ nF}$  to pin CP. A double diode has to be implemented for proper function of the charge pump. An external series resistor is recommended to suppress spikes during switching of the SVSAT. The CP block is supplied by EVZ and VSAT voltage and starts to operate as soon as the thresholds for VK15, K30 and EVZ are achieved. An additional start-up circuitry is implemented to support the VSAT driver during the start-up phase, thus enabling a reliable system startup.

The charge pump has an output CP-OUT to supply the external circuitry, and can be switched via the SPI. It is capable of  $250 \mu\text{A}$ .

**Figure 7-1.** Block Diagram Charge Pump

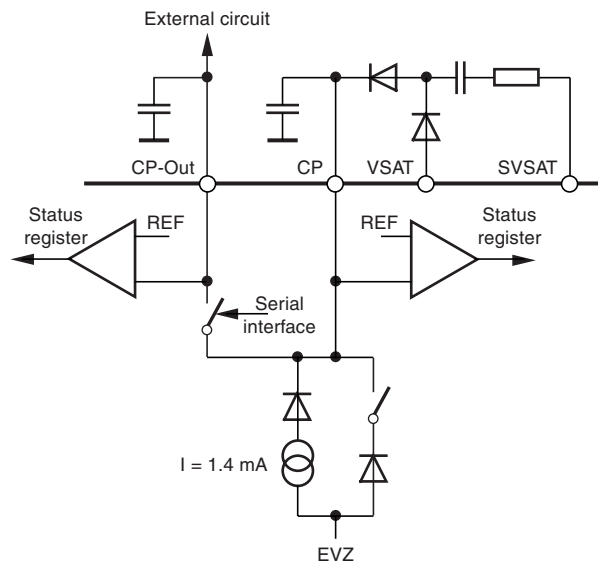

Note: 1. Connected to the drivers (see [Figure 5-3](#))

Necessary for operation:

$$V_{EVZ} = 5.5V \text{ to } 40V \text{ or } V_{K30} = 5.5V \text{ to } 40V, V_{K15} > 3V, V_{VINT} = 3.7V \text{ to } 5.47V$$

Operating conditions of all other supply pins:

$$V_{VSAT}, V_{VPERI} \text{ and } V_{VCORE} \text{ are within functional range limits, } T_j = -40^{\circ}C \text{ to } 150^{\circ}C$$

Other pins:

As defined in [Section 4. "Functional Range" on page 8.](#)

**Table 7-1.** Electrical Characteristics – Charge Pump

| No.  | Parameters   | Test Conditions   | Pin    | Symbol       | Min           | Typ. | Max.           | Unit    | Type* |
|------|--|---|--------|--------------|---------------|------|----------------|---------|-------|
| 6.11 | Supply current at pin CP   | CP off, supply of internal circuitry  | CP     | $I_{CP}$     | 0             |      | 50             | $\mu A$ | A     |
| 6.12 | Time between wrong CP-OUT voltage and valid data in status register  |   | CP-OUT | $t_d$        | 0             |      | 50             | $\mu s$ | A     |
| 6.13 | Current limitation at pin CP-OUT                                     |   | CP-OUT | $I_{CP-OUT}$ | -0.8          |      | -4.2           | mA      | A     |
| 6.14 | Voltage difference $V_{CP} - V_{EVZ}$ for detecting wrong CP         | Note: Threshold is in the range of 5V to 7V   | CP     | $V_{Diff}$   |               |      | 5              | V       | A     |
| 6.15 | Time between wrong CP voltage and valid data in status register      |   | CP     | $t_d$        | 0             |      | 50             | $\mu s$ | A     |
| 6.16 | Voltage difference $V_{CP-OUT} - V_{EVZ}$ for detecting wrong CP-OUT | Note: Threshold is in the range of 5V to 7V   | CP-OUT | $V_{Diff}$   |               |      | 5              | V       | A     |
| 6.17 | Voltage at pin CP  | $V_{EVZ} = 5.5V \text{ to } 40V,$<br>$V_{K30} < V_{EVZ}$<br>$I_{CP} + I_{CP\_Out} = -100 \mu A$<br>(current consumption of $V_{SAT}$ and $V_{CORE}$ have to be added) | CP     | $V_{CP}$     | $V_{EVZ} + 7$ |      | $V_{EVZ} + 11$ | V       | A     |
| 6.18 | Voltage at pin CP  | $V_{EVZ} = 5.5V \text{ to } 40V,$<br>$V_{K30} < V_{EVZ}$<br>$I_{CP} + I_{CP\_Out} = -100 \mu A$<br>(current consumption of $V_{SAT}$ and $V_{CORE}$ have to be added) | CP     | $V_{CP}$     | $V_{K30} + 7$ |      | $V_{K30} + 11$ | V       | A     |

\*) Type means: A = 100% tested, B = 100% correlation tested, C = Characterized on samples, D = Design parameter

## 8. GKEY Function

The GKEY function is used to enable or disable the ECU via a powerless signal. If the voltage at pin K15 is larger than 3V to 4.15V, the charge pump and the EVZ regulator (for correct EVZ function, the K30 pin has to be connected to the battery) will start operating. If the K15 pin is open, an internal pull-down resistor of approximately 220 kΩ discharges the pin. A logical connection between the voltage at the K15 pin, a serial-interface-driven latch command, and the K30 voltage determines the EVZ Enable signal. In order to achieve the *Switch Function* of the GKEY function, a transformer has to be used.

**Table 8-1.** Overview of the Start-up Conditions

| $V_{K30}$          | $V_{K15}$          | Serial-interface-driven Latch<br>(Default: "0" = OFF) | EVZ Regulator |
|--------------------|--------------------|---|---------------|
| Low <sup>1)</sup>  | x                  | x   | Disabled      |
| High <sup>2)</sup> | High <sup>3)</sup> | x   | Enabled       |
| High <sup>2)</sup> | x                  | 1   | Enabled       |

- Note:
1. Less than the value shown in number 7.3 of [Table 8-2 on page 23](#)
  2. Greater than the value shown in number 7.3 of [Table 8-2 on page 23](#)
  3. Greater than the value shown in number 7.1 of [Table 8-2 on page 23](#)

**Figure 8-1.** Application With Low-current Switch (GKEY Function Used)

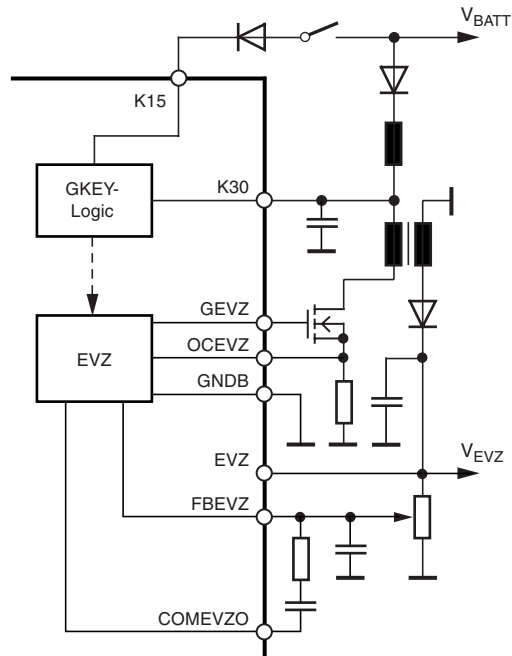

**Figure 8-2.** Application With High Current Switch (GKEY Function Not Used)

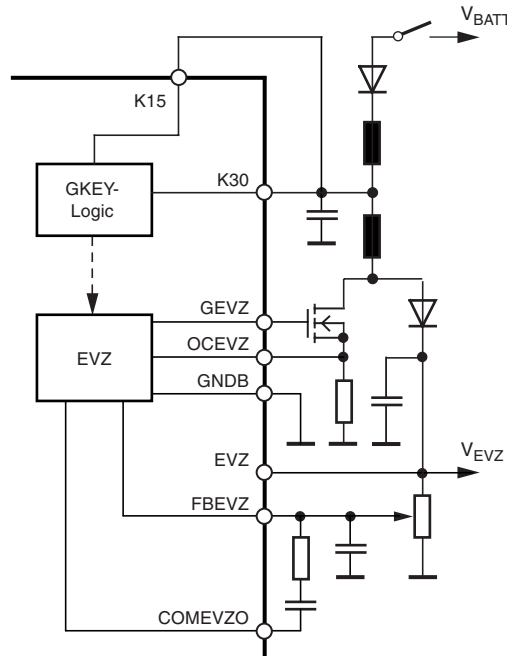

Necessary for operation:

$$V_{K15} = 3V \text{ to } 40V, V_{K30} = 3.85V \text{ to } 40V$$

Operating conditions of all other supply pins:

$$V_{EVZ}, V_{SAT}, V_{PERI} \text{ and } V_{CORE} \text{ are within functional range limits, } T_j = -40^\circ\text{C to } 150^\circ\text{C}$$

Other pins:

As defined in [Section 4. "Functional Range" on page 8.](#)

**Table 8-2.** Electrical Characteristics – GKEY Function

| No. | Parameters                                       | Test Conditions  | Pin | Symbol    | Min  | Typ. | Max. | Unit       | Type* |
|-----|--|--|-----|-----------|------|------|------|------------|-------|
| 7.1 | Voltage level at K15 to enable the EVZ regulator | $V_{K15}$ increasing,<br>$V_{K30} > 5V$                        | K15 | $V_{K15}$ | 3    |      | 4.15 | V          | A     |
| 7.2 | Hysteresis at K15 to disable the EVZ regulator   |  | K15 | $V_{K15}$ | 40   |      | 175  | mV         | A     |
| 7.3 | Voltage level at K30 to enable the EVZ regulator | $V_{K30}$ increasing,<br>$V_{K15} > 4.15V$                     | K30 | $V_{K30}$ | 3.85 |      | 5    | V          | A     |
| 7.4 | Hysteresis at K30 to disable the EVZ regulator   |  | K30 | $V_{K30}$ | 50   |      | 150  | mV         | A     |
| 7.5 | Pull-down resistor at K15                        |  | K15 | $R_{K15}$ | 70   |      | 365  | k $\Omega$ | A     |
| 7.6 | Pull-down resistor at K30                        |  | K30 | $R_{K30}$ | 320  |      | 1700 | k $\Omega$ | A     |
| 7.7 | Current at K15                                   | $0V \leq V_{K15} \leq 40V$ ,<br>AMUX measurement<br>EVZ active | K15 | $I_{K15}$ | 0    |      | 1.1  | mA         | A     |

\*) Type means: A = 100% tested, B = 100% correlation tested, C = Characterized on samples, D = Design parameter

## 9. EVZ Step-up Regulator

A boost converter generates the supply voltage for energy reserve and firing capacitors in the system. Using a voltage divider at pin FBEVZ, this voltage can be adjusted between 15V and 40V. Thus, high-voltage charged capacitors will be used to supply the whole system during the stand-alone time (for example, broken K30 line after a crash). The step-up regulator has to start running as soon as a certain threshold voltage at the K15 pin is exceeded. The regulator has to stop running again if the voltage at the K15 pin falls below a voltage level (or voltage at pin K30 is missing, see [Section 5.3 "Start-up and Power-down Procedure" on page 14](#)).

An inductor is PWM-switched by an external n-channel power FET with a fixed frequency of 100 kHz. A driver stage for the external FET is integrated into the ATA6264. The current limitation of the external FET is implemented by using an external resistor in series between the source connection of the external FET and GND, sensing the voltage drop at this resistor via the pins OCEVZ and GNDA.

The reference section provides a reference voltage of 1.24V for the regulation loop. An error amplifier compares the reference voltage with the feedback signal, which is provided either from two different serial-interface-programmable internal dividers (VEVZ1 = 22V, VEVZ2 = 31.5V) or an external voltage divider network (VEVZExt). These dividers determine the output voltage EVZ.

**Figure 9-1.** EVZ Regulator With External Divider

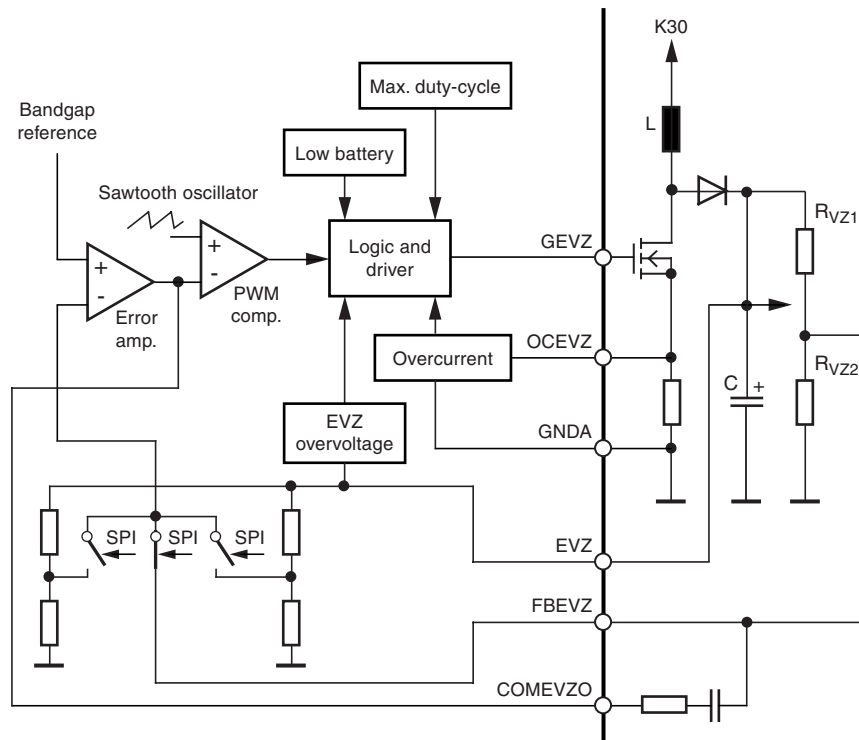
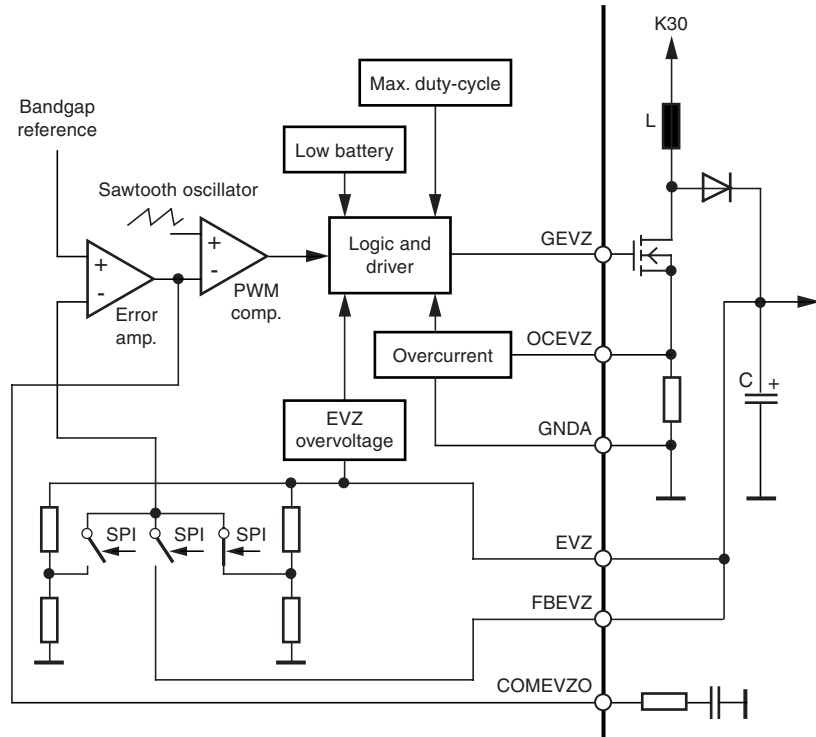



Figure 9-2. EVZ Regulator With Internal Divider



A draft formula for calculating the EVZ voltage, which is programmed by the external voltage divider network at pin FBEVZ, is:

$$V_{EVZ} = V_{REF} \times \frac{R_{VZ1} + R_{VZ2}}{R_{VZ2}}$$

The pins EVZ and FBEVZ have to be shorted in applications without an external divider in order to ensure a safe operation of the ATA6264 in the case of an EVZ-pin fault. If the voltage at pin FBEVZ is larger than the voltage at pin EVZ, the ATA6264 switches the feedback path automatically to pin FBEVZ. The remaining voltage at FBEVZ causes the regulator to switch off.

The output of the error amplifier is compared with a periodic linear ramp of a saw-tooth generator by the PWM comparator. A logic signal with variable pulse width is generated, which controls the PWM frequency of the external FET. A maximum duty cycle is determined by the duration of the falling ramp of the saw-tooth oscillator. The saw-tooth generator is controlled by the internal 100-kHz oscillator.

**Figure 9-3.** Functional Principle of the EVZ Regulator

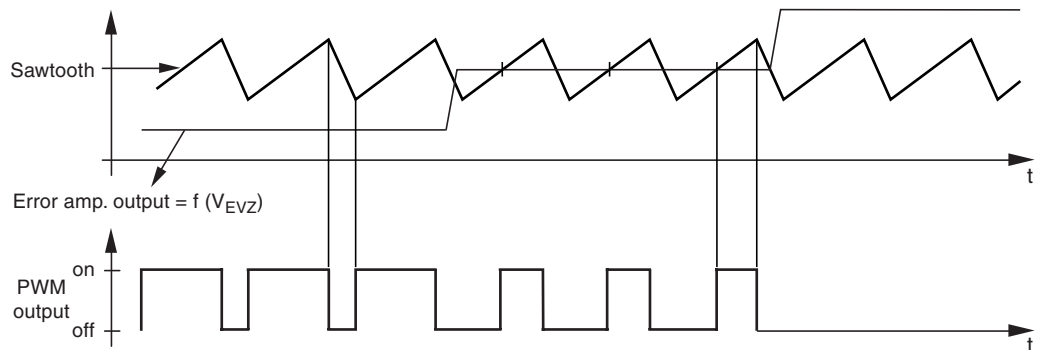

The output transistor conduction is suppressed immediately if the current through the power FET exceeds a certain level, determined by the voltage drop across an external resistor in the range of  $0.2\Omega$ . The ATA6264 itself will see a voltage at the OCEVZ pin. If this voltage exceeds typically  $0.5V$ , the output transistor conduction has to be suppressed.

The external FET also has to be switched off if a low battery voltage at K30 or overvoltage on pin EVZ is detected. Multiple output pulses at pin GEVZ during one oscillator period are suppressed by internal logic.

In the default state - for example, before the minimum input voltage for starting the regulator has been reached - the external transistor is switched off.

During startup, the voltage on pin EVZ is too low and the PWM comparator requires a duty cycle of more than 90%. Due to an increasing inductance current, after several periods the overcurrent sensor becomes active and reduces the maximum duty cycle to improve magnetic energy transfer.

**Figure 9-4.** Output Current During Start-up

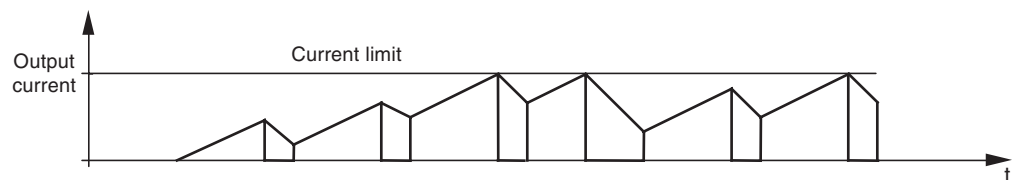

A capacitance of  $10\text{ mF}$  or more may be applied at pin EVZ. The equivalent series resistance (ESR) should have a value of less than  $0.5\Omega$ .

After power-on, the default state of the internal dividers should always be the low EVZ voltage divider.

The voltage at pin GNDA is compared with the voltage at pin GNDD, and if GNDA is not connected, bit b6 of the APACE status register is set. Pin GNDB is also compared with pin GNDD. Pin GNDB not being connected will also result in bit b6 being set, and, additionally, in the EVZ regulator being switched off.

Necessary for operation:

$$V_{K15} = 3V \text{ to } 40V, V_{K30} = 5V \text{ to } 40V, C_{GEVZ} = 200 \text{ pF to } 2 \text{ nF}, V_{INT} = 3.7V \text{ to } 5.47V$$

Operating conditions of all other supply pins:

$$V_{SAT}, V_{PERI} \text{ and } V_{CORE} \text{ are within functional range limits, } T_j = -40^\circ\text{C to } 150^\circ\text{C}$$

Other pins:

As defined in [Section 4. "Functional Range" on page 8.](#)

**Table 9-1.** Electrical Characteristics – EVZ Step-up Regulator

| No.  | Parameters  | Test Conditions  | Pin   | Symbol      | Min              | Typ. | Max.      | Unit       | Type* |
|------|---|--|-------|-------------|------------------|------|-----------|------------|-------|
| 8.1  | Switching frequency   | $V_{K30} \geq 8V$ or $V_{EVZ} \geq 8V$<br>(after startup)                      | GEVZ  | $f_{GEVZ}$  | -5%              | 100  | +5%       | kHz        | A     |
| 8.2  | Switching frequency   | $4V < V_{K30} < 8V$ or<br>$4V < V_{EVZ} < 8V$<br>(after startup)               | GEVZ  | $f_{GEVZ}$  | -10%             | 100  | +10%      | kHz        | A     |
| 8.3  | Voltage level at K15 to start the EVZ regulator                   | See number 7.1 of<br><a href="#">Table 8-2 on page 23</a>                      |       |             |                  |      |           |            | A     |
| 8.4  | Hysteresis at K15 to stop the EVZ regulator                       | See number 7.2 of<br><a href="#">Table 8-2 on page 23</a>                      |       |             |                  |      |           |            | A     |
| 8.5  | Voltage level at K30 to start the EVZ regulator                   | See number 7.3 of<br><a href="#">Table 8-2 on page 23</a>                      |       |             |                  |      |           |            | A     |
| 8.6  | Hysteresis at K30 to stop the EVZ regulator                       | See number 7.4 of<br><a href="#">Table 8-2 on page 23</a>                      |       |             |                  |      |           |            | A     |
| 8.7  | Voltage at pin GEVZ to switch through the external driver         | $V_{K30} \geq 3.85V$ to $5V$<br>(ON threshold)                                 | GEVZ  | $V_{GEVZ}$  | $V_{K30} - 0.5V$ |      | $V_{K30}$ | V          | A     |
| 8.8  | Voltage at pin GEVZ to switch through the external driver         | $V_{K30} \geq 7V$  | GEVZ  | $V_{GEVZ}$  | 6                |      | 10        | V          | A     |
| 8.9  | Driving current at pin GEVZ to switch through the external driver | $V_{GEVZ} \leq 5V$   | GEVZ  | $I_{GEVZ}$  | -600             |      | -80       | mA         | A     |
| 8.10 | Gate charge delivered to the external FET                         | $V_{GEVZ} = 5V$  | GEVZ  | $Q_{GEVZ}$  | 10               |      |           | nC         | D     |
| 8.11 | Gate charge delivered to the external FET                         | $V_{GEVZ} = 10V$   | GEVZ  | $Q_{GEVZ}$  | 20               |      |           | nC         | D     |
| 8.12 | Pull-down resistor at pin GEVZ                                    |  | GEVZ  | $R_{GEVZ}$  | 20               |      | 50        | k $\Omega$ | A     |
| 8.13 | $R_{Dson}$ of dynamic sinking transistor at GEVZ                  |  | GEVZ  | $R_{GEVZ}$  |                  |      | 28        | $\Omega$   | A     |
| 8.15 | Voltage between pins OCEVZ and GND to detect overcurrent          |  | OCEVZ | $V_{OCEVZ}$ | 0.475            |      | 0.525     | V          | A     |
| 8.16 | Maximum switch duty cycle   | $V_{K30} \geq 8V$ or $V_{EVZ} \geq 8V$<br>(after startup)<br>$V_{EVZ} \geq 8V$ | GEVZ  | $D_{GEVZ}$  | 87.5             | 90   | 92.5      | %          | A     |
| 8.17 | Maximum switch duty cycle   | $4V < V_{K30} < 8V$ or<br>$4V < V_{EVZ} < 8V$<br>(after startup)               | GEVZ  | $D_{GEVZ}$  | 75               | 90   | 92.5      | %          | A     |
| 8.18 | Minimum switch duty cycle   |  | GEVZ  | $D_{GEVZ}$  |                  |      | 0         | %          | A     |
| 8.19 | Overvoltage at pin EVZ to switch off the regulator                | $V_{EVZExt}$ programmed<br>(via external divider)                              | VEVZ  | $V_{EVZ}$   | 40.5             |      | 46.2      | V          | A     |

\*) Type means: A = 100% tested, B = 100% correlation tested, C = Characterized on samples, D = Design parameter

**Table 9-1. Electrical Characteristics (Continued)– EVZ Step-up Regulator**

| No.   | Parameters   | Test Conditions  | Pin   | Symbol             | Min  | Typ. | Max. | Unit | Type* |
|-------|--|--|-------|--------------------|------|------|------|------|-------|
| 8.19a | Overvoltage at pin EVZ to switch off the regulator         | V <sub>EVZ1</sub> programmed   | VEVZ  | V <sub>EVZ</sub>   | 25   |      | 28.5 | V    | A     |
| 8.19b | Overvoltage at pin EVZ to switch off the regulator         | V <sub>EVZ2</sub> programmed   | VEVZ  | V <sub>EVZ</sub>   | 35   |      | 39.5 | V    | A     |
| 8.20  | Overvoltage switch-off time                                | Time between reaching overvoltage and reaching 90% of the value at numbers 8.7 and 8.8 of <a href="#">Table 9-1 on page 27</a> | GEVZ  | t <sub>offov</sub> |      |      | 200  | ns   | D     |
| 8.21  | Overcurrent switch-off time                                | Time between reaching overcurrent and reaching 90% of the value at numbers 8.7 and 8.8 of <a href="#">Table 9-1 on page 27</a> | GEVZ  | t <sub>offoc</sub> |      |      | 500  | ns   | A     |
| 8.22  | Switch-on delay time for the boost converter output stage  |  | GEVZ  | t <sub>don</sub>   | 50   |      | 250  | ns   | A     |
| 8.23  | Switch-on rise time for the boost converter output stage   | Time between 0.5V and 4.5V at GEVZ, C <sub>GEVZ</sub> = 2 nF   | GEVZ  | t <sub>ron</sub>   | 10   |      | 200  | ns   | A     |
| 8.24  | Switch-off delay time for the boost converter output stage |  | GEVZ  | t <sub>doff</sub>  | 50   |      | 150  | ns   | A     |
| 8.25  | Switch-off fall time for the boost converter output stage  | Time between 4.5V and 0.5V at GEVZ, C <sub>GEVZ</sub> = 2 nF   | GEVZ  | t <sub>foff</sub>  | 10   |      | 100  | ns   | A     |
| 8.26  | Leakage current at pin OCEVZ                               |  | OCEVZ | I <sub>OCEVZ</sub> | -10  |      | +10  | μA   | A     |
| 8.27  | Leakage current at pin FBEVZ                               |  | FBEVZ | I <sub>OCEVZ</sub> | -10  |      | +10  | μA   | A     |
| 8.28  | Switch-on threshold via FBEVZ                              | Band-gap tolerance included  | FBEVZ | V <sub>FBEVZ</sub> | 1.20 | 1.24 |      | V    | A     |
| 8.29  | Switch-on threshold via FBEVZ                              | Band-gap tolerance included  | FBEVZ | V <sub>FBEVZ</sub> |      | 1.24 | 1.28 | V    | A     |
| 8.30  | V <sub>EVZ</sub> voltage #1 set by SPI                     | V <sub>EVZ1</sub> programmed, Band-gap tolerance included  | EVZ   | V <sub>EVZ1</sub>  | 20   |      | 23   | V    | A     |
| 8.31  | V <sub>EVZ</sub> voltage #2 set by SPI                     | V <sub>EVZ2</sub> programmed, Band-gap tolerance included  | EVZ   | V <sub>EVZ2</sub>  | 28.6 |      | 33   | V    | A     |
| 8.31a | Temperature shutdown activation                            |  |       | T <sub>off</sub>   | 155  |      | 185  | °C   | B     |
| 8.31b | Hysteresis for reactivation of GEVZ                        |  |       | T <sub>hys</sub>   | 5    |      | 25   | K    | B     |

\*) Type means: A = 100% tested, B = 100% correlation tested, C = Characterized on samples, D = Design parameter

Table 9-1. Electrical Characteristics (Continued)– EVZ Step-up Regulator

| No.                         | Parameters                                    | Test Conditions                         | Pin     | Symbol               | Min                            | Typ. | Max. | Unit          | Type* |
|-----------------------------|---|---|---------|----------------------|--------------------------------|------|------|---------------|-------|
| <b>Error Amplifier</b>      |   |   |         |                      |                                |      |      |               |       |
| 8.32                        | Output current at pin COMEVZO sinking to low  |   | COMEVZO | $I_{\text{COMEVZO}}$ | 0.4                            |      | 3    | mA            | A     |
| 8.33                        | Output current at pin COMEVZO driving to high |   | COMEVZO | $I_{\text{COMEVZO}}$ | -1000                          |      | -150 | $\mu\text{A}$ | A     |
| 8.34                        | Input offset voltage                          |   |         |                      | -10                            |      | +10  | mV            | D     |
| 8.35                        | DC open-loop gain                             |   |         |                      | 70                             |      |      | dB            | D     |
| 8.36                        | Unity-gain bandwidth                          |   |         |                      | 2                              |      |      | MHz           | D     |
| 8.37                        | Output voltage low on pin COMEVZO             | $I_{\text{COMEVZO}} = 100 \mu\text{A}$  | COMEVZO | $V_{\text{COMEVZO}}$ | 0                              |      | 0.2  | V             | A     |
| 8.38                        | Output voltage high on pin COMEVZO            | $I_{\text{COMEVZO}} = -100 \mu\text{A}$ | COMEVZO | $V_{\text{COMEVZO}}$ | $V_{\text{INT}} - 0.3\text{V}$ |      | VINT | V             | A     |
| <b>GNDA/GNDB Disconnect</b> |   |   |         |                      |                                |      |      |               |       |
| 8.40                        | GNDA lost detection                           | $V_{\text{GNDA}} - V_{\text{GNDD}}$     | GNDA    | $V_{\text{GNDA}}$    | 0.2                            |      | 0.4  | V             | A     |
| 8.41                        | Delay for GNDA lost detection                 |   | GNDA    | td                   | 10                             |      | 50   | $\mu\text{s}$ | A     |
| 8.42                        | GNDB lost detection                           | $V_{\text{GNDB}} - V_{\text{GNDD}}$     | GNDB    | $V_{\text{GNDB}}$    | 0.2                            |      | 0.4  | V             | A     |

\*) Type means: A = 100% tested, B = 100% correlation tested, C = Characterized on samples, D = Design parameter

## 10. VSAT Power Supply

A stabilized VSAT supply is realized by a buck converter. An external inductance is PWM-switched with a frequency of 200 kHz via an internal high-side DMOS power transistor. The VSAT power supply is connected to the boost converter output (EVZ), and uses the stored energy of the boost converter capacitor if the voltage at K30 is missing. The regulator uses both current and voltage feedback. The basis for the regulation loop is a temperature-compensated band-gap reference voltage, which is compared with the internally divided output voltage VSAT. The error amplifier output is applied to the inverting input of a comparator, the current feedback is connected with the positive input. The PWM flip-flop (which is set every 5  $\mu$ s by the oscillator) is reset if the current feedback reaches the error amplifier level. In order to adjust the compensation of the regulation loop and therefore improve the behavior in case of load changes in continuous-mode operation, pin COMSATO has to be connected to COMSATI via a compensation network. Because of the fact that current-mode-controlled converters exhibit sub-harmonic oscillations when operating at duty cycles higher than 50%, a slope compensation (which adds an artificial ramp to the comparator) is implemented. If the regulator input voltage at pin EVZ is too low, the regulator switches to a duty cycle of 100% (Permanent-on mode).

The VSAT voltage can be programmed via the serial interface to one of three different voltage values during initial programming.

**Figure 10-1.** Functional Principle of the VSAT Regulator

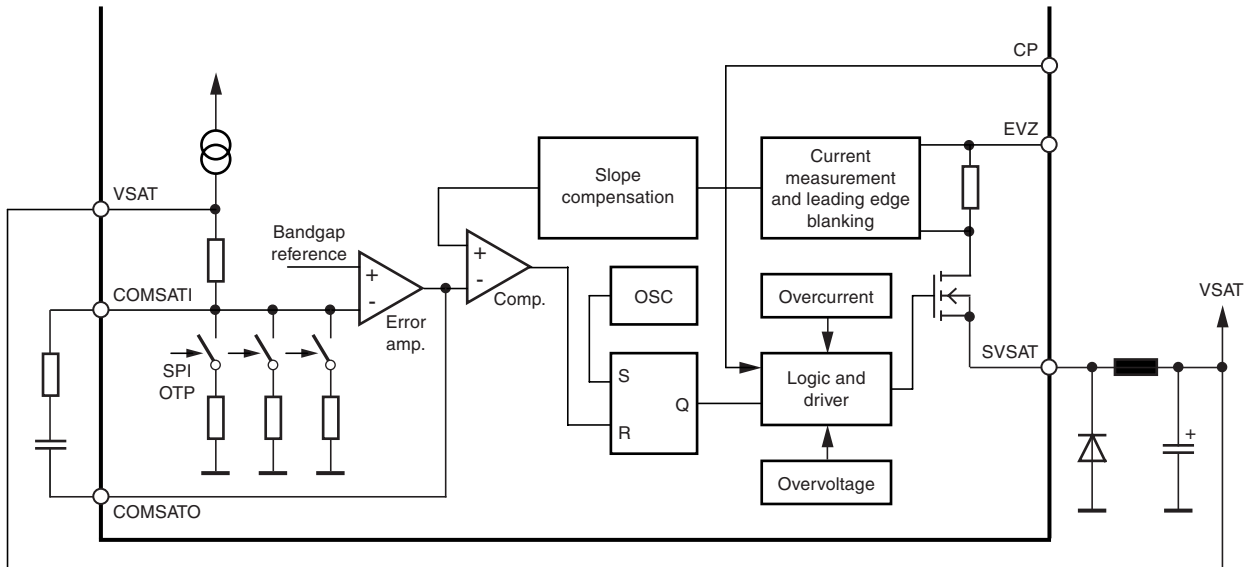

The duration of the output transistor conduction depends on the VSAT level and current feedback. Conduction is suppressed immediately if the current through the output transistor exceeds 850 mA typically. A logic circuit disables, in the case of short spikes, multiple-pulse operation during one oscillating period. If pin VSAT is open (VSAT loss), an internal current source connected to a higher voltage than VSAT acts as pull-up for this pin, to prevent the VSAT voltage from rising up to EVZ. In order to ensure the gate voltage for the output transistor, the driver stage is supplied by the charge pump (pin CP).

Necessary for operation:

$$V_{EVZ} = 5.5V \text{ to } 40V, V_{CP} > V_{EVZ} + 7V, V_{INT} = 3.7V \text{ to } 5.45V$$

Operating conditions of all other supply pins:

$$V_{K30}, V_{PERI} \text{ and } V_{CORE} \text{ are within functional range limits, } T_j = -40^\circ\text{C to } +150^\circ\text{C}$$

Other pins:

As defined in [Section 4. "Functional Range" on page 8.](#)

**Table 10-1.** Electrical Characteristics – VSAT Power Supply

| No.  | Parameters  | Test Conditions   | Pin   | Symbol         | Min  | Typ. | Max.                  | Unit          | Type* |
|------|---|---|-------|----------------|------|------|-----------------------|---------------|-------|
| 9.1  | $V_{EVZ}$ voltage for the buck converter to start running |   | EVZ   | $V_{EVZ}$      | 7.5  |      | 9                     | V             | A     |
| 9.2  | $V_{EVZ}$ voltage for the buck converter to stop          |   | EVZ   | $V_{EVZ}$      | 5.5  |      | 6.2                   | V             | A     |
| 9.3  | Regulator switch-on time via pin EVZ                      |   | SVSAT | $t_{SVSAT}$    | 0    |      | 20                    | $\mu\text{s}$ | A     |
| 9.4  | Regulator switch-off time via pin EVZ                     |   | SVSAT | $t_{SVSAT}$    | 0    |      | 5                     | $\mu\text{s}$ | A     |
| 9.5  | Regulator switching frequency                             | $V_{EVZ} \geq 8V$   | SVSAT | $f_{SVSAT}$    | -5%  | 200  | +5%                   | kHz           | A     |
| 9.5a | Regulator switching frequency                             | $5.5V > V_{EVZ} \geq 8V$  | SVSAT | $f_{SVSAT}$    | -10% | 200  | +10%                  | kHz           | A     |
| 9.6  | Output current limit                                      |   | SVSAT | $I_{SVSAT}$    | 0.8  |      | 1                     | A             | A     |
| 9.7  | $R_{Dson}$ of output transistor                           |   | SVSAT | $R_{SVSAT}$    |      |      | 1                     | $\Omega$      | A     |
| 9.8  | Output voltage #1 only at $V_{PERI} = 3.3V$               | Band-gap tolerance included   | VSAT  | $V_{VSAT1}$    | -4%  | 7.8  | +4%                   | V             | A     |
| 9.9  | Output voltage #2   | $V_{VSAT2}$ programmed, Band-gap tolerance included   | VSAT  | $V_{VSAT2}$    | -4%  | 9.1  | +4%                   | V             | A     |
| 9.10 | Output voltage #3   | $V_{VSAT3}$ programmed, Band-gap tolerance included   | VSAT  | $V_{VSAT3}$    | -4%  | 10.4 | +4%                   | V             | A     |
| 9.11 | Output transistor switch-on time                          | Time between reaching $0.1 \times (V_{EVZmax} - V_{SVSATmin})$ and $0.9 \times (V_{EVZmax} - V_{SVSATmin})$ |       |                |      |      | 150                   | ns            | A     |
| 9.12 | Output transistor switch-on time                          | Time between reaching $0.9 \times (V_{EVZmax} - V_{SVSATmin})$ and $0.1 \times (V_{EVZmax} - V_{SVSATmin})$ |       |                |      |      | 150                   | ns            | A     |
| 9.13 | Overshoot switching off the regulator                     |   | VSAT  | $V_{VSAT}$     |      |      | $1.1 \times V_{SATX}$ | V             | A     |
| 9.14 | Overshoot switch-on time                                  | Time between reaching overshoot and reaching 90% of $V_{SVSAT}$ maximum under on condition                  | SVSAT | $t_{SVSAToff}$ | 0    |      | 0.4                   | $\mu\text{s}$ | A     |

\*) Type means: A = 100% tested, B = 100% correlation tested, C = Characterized on samples, D = Design parameter

Notes: 1. Depending on implementation of slope compensation; sub-harmonics must be prevented

2. The value of the minimum load current must be higher than the internal pull-up current at pin VSAT to ensure proper function of the regulator



**Table 10-1. Electrical Characteristics (Continued)– VSAT Power Supply**

| No.                    | Parameters   | Test Conditions  | Pin     | Symbol         | Min                | Typ. | Max.               | Unit        | Type* |
|------------------------|--|--|---------|----------------|--------------------|------|--------------------|-------------|-------|
| 9.15                   | Overcurrent switch-on time                             | Time between reaching overcurrent and reaching 90% of $V_{SVSAT}$ maximum under on condition | SVSAT   | $t_{SVSAToff}$ | 0                  |      | 0.5                | $\mu s$     | A     |
| 9.16                   | Leakage current at pin SVSAT                           | Output transistor off  | SVSAT   | $I_{SVSAT}$    | -10                |      | +10                | $\mu A$     | A     |
| <b>Error Amplifier</b> |  |  |         |                |                    |      |                    |             |       |
| 9.17                   | Maximum output current at pin COMSATO sinking to low   |  | COMSATO | $I_{COMSATO}$  | 200                |      | 3000               | $\mu A$     | A     |
| 9.18                   | Maximum output current at pin COMSATO sourcing to high |  | COMSATO | $I_{COMSATO}$  | -165               |      | -85                | $\mu A$     | A     |
| 9.19                   | Input impedance at pin COMSATI                         |  | COMSATI | $R_{COMSATI}$  | 9                  |      | 23                 | $k\Omega$   | A     |
| 9.20                   | Input offset voltage                                   |  |         |                | -10                |      | +10                | mV          | D     |
| 9.21                   | DC open-loop gain                                      |  |         |                | 70                 |      |                    | dB          | D     |
| 9.22                   | Unity-gain bandwidth                                   |  |         |                | 2                  |      |                    | MHz         | D     |
| 9.23                   | Output voltage low                                     | $I_{COMSATO} = 165 \mu A$  | COMSATO | $V_{COMSATO}$  | 0                  |      | 0.3                | V           | A     |
| 9.24                   | Output voltage high                                    | $I_{COMSATO} = -85 \mu A$  | COMSATO | $V_{COMSATO}$  | $V_{VINT} - 0.6V$  |      | $V_{VINT}$         | V           | A     |
| 9.25                   | Leading-edge blanking time                             |  |         | $t_{blank}$    | 150                |      | 200                | ns          | D     |
| 9.26                   | Slope of artificial ramp for slope compensation        |  |         | $dV/dt$        | 150 <sup>(1)</sup> |      | 240 <sup>(1)</sup> | mV/ $\mu s$ | D     |
| 9.27                   | VSAT loss detection threshold <sup>(2)</sup>           |  |         | $I_{Load}$     | 0                  |      | 1.5                | mA          | D     |

\*) Type means: A = 100% tested, B = 100% correlation tested, C = Characterized on samples, D = Design parameter

- Notes:
1. Depending on implementation of slope compensation; sub-harmonics must be prevented
  2. The value of the minimum load current must be higher than the internal pull-up current at pin VSAT to ensure proper function of the regulator



## 11. VPERI Power Supply

With the  $V_{\text{PERI}}$  regulator a stabilized and ripple-free voltage is generated out of the  $V_{\text{SAT}}$  supply voltage. This voltage is intended to be used for sensitive components, for example, sensors or reference inputs of A/D converters from microcontrollers. For this reason, a linear regulator is implemented to guarantee high ripple rejection and a precise voltage. The regulator output is short-circuit protected by an overcurrent protection. If pin  $V_{\text{PERI}}$  is disconnected, the regulator is switched off and  $\text{RESQ}/\text{RESQ2}$  are set to low.

**Figure 11-1.** Functional Principle of the  $V_{\text{Peripheral}}$  Regulator

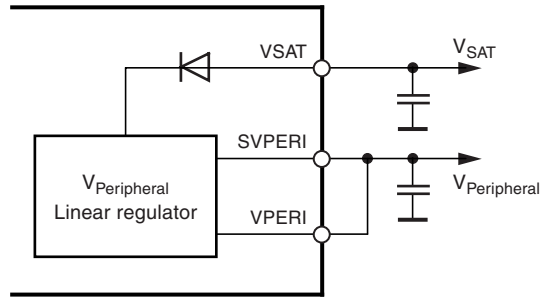

If a higher current capability of the regulator is requested or if the power dissipation of the linear regulator is too high, an external transistor can boost the regulator.

**Figure 11-2.** Functional Principle of the  $V_{\text{PERI}}$  Regulator With External Boost Transistor

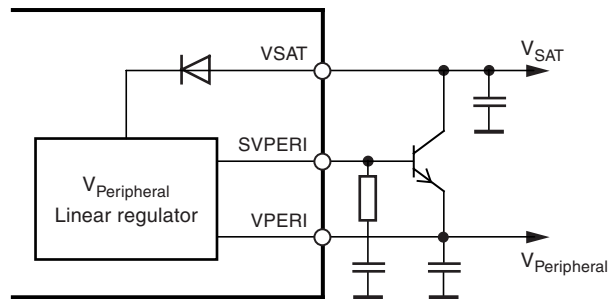

The  $V_{\text{PERI}}$  voltage can be programmed via the serial interface to one of two different voltage values during initial programming.

Necessary for operation:

$$V_{SAT} > 7.5V, V_{INT} = 3.7V \text{ to } 5.47V, V_{CORE} < V_{PERI} + 0.3V$$

Operating conditions of all other supply pins:

$$V_{K30}, V_{EVZ} \text{ and } V_{CORE} \text{ are within functional range limits, } T_j = -40^{\circ}C \text{ to } 150^{\circ}C$$

Other pins:

As defined in [Section 4. "Functional Range" on page 8.](#)

**Table 11-1.** Electrical Characteristics – VPERI Power Supply

| No.   | Parameters                                      | Test Conditions   | Pin   | Symbol      | Min   | Typ. | Max. | Unit | Type* |
|-------|---|---|-------|-------------|-------|------|------|------|-------|
| 10.1  | Voltage level at VSAT to enable VPERI regulator |   | VSAT  | $V_{VSAT}$  | 6.77  |      | 7.2  | V    | A     |
| 10.2  | Hysteresis at VSAT to disable VPERI regulator   |   | VSAT  | $V_{VSAT}$  | 0.2   |      | 0.5  | V    | A     |
| 10.3  | Output voltage #1                               | $V_{VPERI1}$ programmed, band-gap tolerance included  | VPERI | $V_{VPERI}$ | -3.6% | 5    | +4%  | V    | A     |
| 10.4  | Output voltage #2                               | $V_{VPERI2}$ programmed, band-gap tolerance included  | VPERI | $V_{VPERI}$ | -4%   | 3.3  | +3%  | V    | A     |
| 10.5  | Output current                                  | $V_{VSAT} = 7.5V \text{ to } 12.5V$   | VPERI | $I_{VPERI}$ | -100  |      |      | mA   | A     |
| 10.6  | Short-circuit current                           |   | VPERI | $I_{VPERI}$ | -200  |      | -110 | mA   | A     |
| 10.7  | Line regulation                                 | $V_{VSAT} = 8V \text{ to } 12.5V$<br>$I_{PERI} = -1 \text{ mA to } -100 \text{ mA}$<br>( $I_{PERI}$ is constant during measurement)     | VPERI | $V_{VPERI}$ | -10   |      | +10  | mV   | A     |
| 10.8  | Load regulation                                 | $V_{SAT} = 8V \text{ to } 12.5V$ ( $V_{VSAT}$ is constant during measurement)<br>$I_{PERI} = -1 \text{ mA to } -100 \text{ mA}$         | VPERI | $V_{VPERI}$ | -10   |      | +10  | mV   | A     |
| 10.10 | Supply voltage rejection                        | $I_{PERI} = -100 \text{ mA}$ ,<br>$f = 100 \text{ kHz} - 20 \text{ MHz}$ ,<br>$C_{PERI} = 47 \mu\text{F} + 100 \text{ nF}$<br>(ceramic) |       |             | 40    |      |      | dB   | D     |

\*) Type means: A = 100% tested, B = 100% correlation tested, C = Characterized on samples, D = Design parameter

## 12. VCORE Power Supply

The voltage of the VCORE regulator is generated out of the K30 voltage using a step-down regulator as long as the K30 voltage is available. During times when K30 is not present (power-down or stand-alone time), the VCORE regulator is supplied out of VEZ. Depending on the initial programming, the supply switch signal is derived from the CORESWAP comparator or the EVZEN comparator. The VCORE voltage can be programmed via the serial interface to 3 different voltage values during initial programming. In the case of short spikes, a logic circuit disables multiple-pulse operation during one oscillating period. The regulator uses both current and voltage feedback. In the following cases, the output transistor of the regulator is switched off at once and may be switched on again with the beginning of the next clock period:

1. If the current through the transistor exceeds the output current limit value, the transistor is switched off immediately.
2. If overvoltage is detected at the pin VCORE, the transistor is switched off immediately.
3. If the feedback voltage at the pin VCORE is missing (disconnected pin), the regulator is switched off.

**Figure 12-1.** Functional Principle of the VCORE Regulator

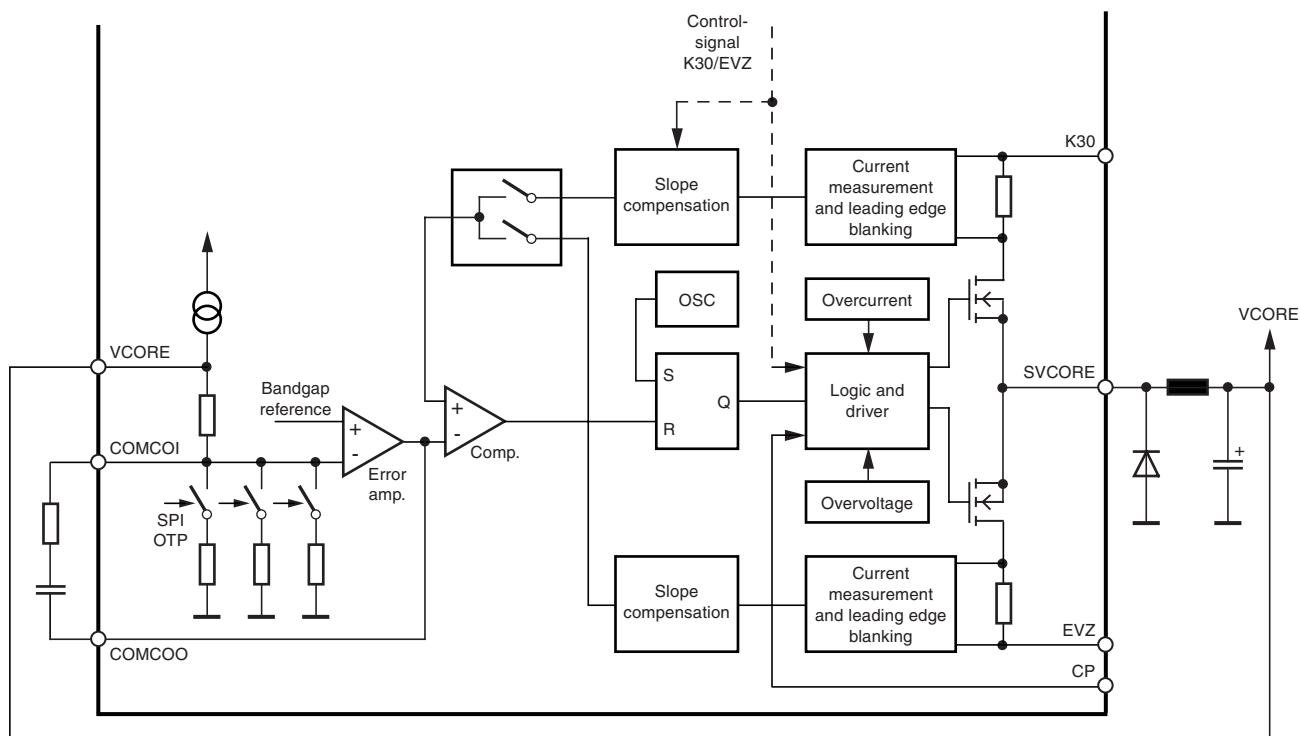

In order to trim the compensation of the regulation loop and to improve the behavior at load changes, pin COMCOO has to be connected to COMCOI via a compensation network. Because of the fact that current-mode-controlled converters exhibit sub-harmonic oscillations when operating at duty cycles larger than 50%, a slope compensation (which adds an artificial ramp to the comparator) is implemented. If the regulator input voltage at pin EVZ or pin K30 is too low, the regulator switches to a duty cycle of 100% (Permanent-on mode). Backward feeding of EVZ and K30 is avoided. In order to ensure the gate voltage for the output transistors of the regulator, the driver stages are supplied by the charge pump (pin CP).

Necessary for operation:

$$V_{EVZ} = 5.5V \text{ to } 40V \text{ or } V_{K30} = 5.5V \text{ to } 40V, V_{CP} > V_{EVZ} + 7V \text{ or } V_{CP} > V_{K30} + 7V, \\ V_{PERI} > V_{CORE} - 0.3V, V_{INT} = 3.7V \text{ to } 5.47V$$

Operating conditions of all other supply pins:

$$V_{SAT} \text{ is within functional range limits, } T_j = -40^{\circ}C \text{ to } 150^{\circ}C$$

Other pins:

As defined in [Section 4. "Functional Range" on page 8](#).

**Table 12-1.** Electrical Characteristics – V<sub>CORE</sub> Power Supply

| No.   | Parameters   | Test Conditions   | Pin                           | Symbol                                    | Min  | Typ. | Max. | Unit | Type* |
|-------|--|---|-------------------------------|---|------|------|------|------|-------|
| 11.1  | V <sub>EVZ</sub> voltage for the V <sub>CORE</sub> regulator to start running              | Initial programming:<br>V <sub>V<sub>CORE</sub></sub> = 5V or 2.5V  | EVZ                           | V <sub>EVZ</sub>                          | 7.5  |      | 9    | V    | A     |
| 11.1a | V <sub>V<sub>PERI</sub></sub> voltage for the V <sub>CORE</sub> regulator to start running | Initial programming:<br>V <sub>V<sub>CORE</sub></sub> = 1.88V   | V <sub>PERI</sub>             | V <sub>V<sub>PERI</sub></sub>             | 1.25 |      | 1.7  | V    | A     |
| 11.2  | V <sub>EVZ</sub> voltage for the V <sub>CORE</sub> regulator to stop running               | Initial programming:<br>V <sub>V<sub>CORE</sub></sub> = 5V or 2.5V  | EVZ                           | V <sub>EVZ</sub>                          | 5.5  |      | 6.2  | V    | A     |
| 11.2a | Hysteresis at V <sub>PERI</sub> for the V <sub>CORE</sub> regulator to stop running        | Initial programming:<br>V <sub>V<sub>CORE</sub></sub> = 1.88V   | V <sub>PERI</sub>             | V <sub>HYS</sub>                          | 50   |      | 150  | mV   | A     |
| 11.3  | Switch-on time via pin EVZ   |   | S <sub>V<sub>CORE</sub></sub> | t <sub>S<sub>V<sub>CORE</sub></sub></sub> | 0    |      | 20   | μs   | A     |
| 11.4  | Switch-off time via pin EVZ  |   | S <sub>V<sub>CORE</sub></sub> | t <sub>S<sub>V<sub>CORE</sub></sub></sub> | 0    |      | 10   | μs   | A     |
| 11.5  | Regulator switching frequency  | See numbers 8.1 and 8.2 of <a href="#">Table 9-1 on page 27</a>   | S <sub>V<sub>CORE</sub></sub> | f <sub>S<sub>V<sub>CORE</sub></sub></sub> |      |      |      |      | A     |
| 11.6  | Output current limit   |   | S <sub>V<sub>CORE</sub></sub> | I <sub>S<sub>V<sub>CORE</sub></sub></sub> | 0.7  |      | 0.9  | A    | A     |
| 11.7  | R <sub>Dson</sub> of output transistor   |   | S <sub>V<sub>CORE</sub></sub> | R <sub>S<sub>V<sub>CORE</sub></sub></sub> |      |      | 1.2  | Ω    | A     |
| 11.8  | Output voltage #1  | V <sub>V<sub>CORE1</sub></sub> programmed, band-gap tolerance included  | V <sub>CORE</sub>             | V <sub>V<sub>CORE1</sub></sub>            | -4%  | 5.0  | +4%  | V    | A     |
| 11.9  | Output voltage #2  | V <sub>V<sub>CORE2</sub></sub> programmed, band-gap tolerance included  | V <sub>CORE</sub>             | V <sub>V<sub>CORE2</sub></sub>            | -4%  | 2.5  | +4%  | V    | A     |
| 11.10 | Output voltage #3  | V <sub>V<sub>CORE3</sub></sub> programmed, band-gap tolerance included  | V <sub>CORE</sub>             | V <sub>V<sub>CORE3</sub></sub>            | -4%  | 1.88 | +4%  | V    | A     |
| 11.11 | Output transistor switch-on time   | Time between reaching<br>0.1 × (V <sub>K30max</sub> - V <sub>V<sub>CORE</sub>Emin</sub> )<br>and<br>0.9 × (V <sub>K30max</sub> - V <sub>V<sub>CORE</sub>Emin</sub> )<br>or<br>0.1 × (V <sub>EVZmax</sub> - V <sub>V<sub>CORE</sub>Emin</sub> )<br>and<br>0.9 × (V <sub>EVZmax</sub> - V <sub>V<sub>CORE</sub>Emin</sub> ) | S <sub>V<sub>O</sub></sub>    | t <sub>S<sub>V<sub>O</sub></sub>Eon</sub> |      |      | 150  | ns   | A     |

\*) Type means: A = 100% tested, B = 100% correlation tested, C = Characterized on samples, D = Design parameter

- Notes:
1. Depending on implementation of slope compensation, sub-harmonics have to be prevented.
  2. The value of the minimum load current must be higher than the internal pull-up current at pin V<sub>CORE</sub> to ensure proper function of the regulator.

Table 12-1. Electrical Characteristics (Continued)– V<sub>CORE</sub> Power Supply

| No.                    | Parameters  | Test Conditions  | Pin                 | Symbol                            | Min                    | Typ. | Max.             | Unit     | Type* |
|------------------------|---|--|---------------------|-----------------------------------|------------------------|------|------------------|----------|-------|
| 11.12                  | Output transistor switch-off time   | Time between reaching $0.1 \times (V_{K30max} - V_{VCOREmin})$ and $0.9 \times (V_{K30max} - V_{VCOREmin})$ or $0.1 \times (V_{EVZmax} - V_{VCOREmin})$ and $0.9 \times (V_{EVZmax} - V_{VCOREmin})$ | SV <sub>CORE</sub>  | t <sub>SV<sub>CORE</sub>off</sub> |                        |      | 150              | ns       | A     |
| 11.13                  | Overvoltage at pin V <sub>CORE</sub> for switching off the regulator and setting pin RESQ to low (V <sub>CORE</sub> is set to 5V)   | See numbers 14.6 and 14.6a of Table 15-2 on page 45  |                     |                                   |                        |      |                  |          |       |
| 11.13a                 | Overvoltage at pin V <sub>CORE</sub> for switching off the regulator and setting pin RESQ to low (V <sub>CORE</sub> is set to 2.5V) | See numbers 14.7 and 14.7a of Table 15-2 on page 45  |                     |                                   |                        |      |                  |          |       |
| 11.13b                 | Overvoltage at pin V <sub>CORE</sub> for switching off the regulator and setting pin RESQ to low (V <sub>CORE</sub> is set to 1.8V) | See numbers 14.8 and 14.8a of Table 15-2 on page 45  |                     |                                   |                        |      |                  |          |       |
| 11.14                  | Overvoltage switch-off time   | Time between reaching overvoltage and reaching 90% of V <sub>SCORE</sub> maximum under on condition  | SV <sub>O</sub>     | t <sub>SV<sub>O</sub>off</sub>    | 0                      |      | 0.4              | μs       | A     |
| 11.15                  | Overcurrent switch-off time   | Time between reaching overcurrent and reaching 90% of V <sub>SCORE</sub> maximum under on condition  | SV <sub>CORE</sub>  | t <sub>SV<sub>CORE</sub>off</sub> | 0                      |      | 0.5              | μs       | A     |
| 11.16                  | Leakage current at pin SV <sub>CORE</sub>   | Output transistor off  | SV <sub>CORE</sub>  | I <sub>SV<sub>CORE</sub></sub>    | -10                    |      | 10               | μA       | A     |
| <b>Error Amplifier</b> |   |  |                     |                                   |                        |      |                  |          |       |
| 11.17                  | Maximum output current at pin COM <sub>COO</sub> sinking to low   |  | COM <sub>COO</sub>  | I <sub>COM<sub>COO</sub></sub>    | 200                    |      | 3000             | μA       | A     |
| 11.18                  | Maximum output current at pin COM <sub>COO</sub> sourcing to high   |  | COM <sub>COO</sub>  | I <sub>COM<sub>COO</sub></sub>    | -165                   |      | -85              | μA       | A     |
| 11.19                  | Input impedance at pin COM <sub>COI</sub>   | V <sub>CORE</sub> = 1.88V<br>V <sub>CORE</sub> = 2.5V/5V   | COM <sub>COI</sub>  | R <sub>COM<sub>COI</sub></sub>    | 7.5<br>13              |      | 18<br>27         | kΩ<br>kΩ | A     |
| 11.20                  | Input offset voltage  |  |                     |                                   | -10                    |      | 10               | mV       | D     |
| 11.21                  | DC open loop gain   |  |                     |                                   | 70                     |      |                  | dB       | D     |
| 11.22                  | Unity-gain bandwidth  |  |                     |                                   | 2                      |      |                  | MHz      | D     |
| 11.23                  | Output voltage low at pin COM <sub>COO</sub>  | I <sub>COM<sub>COO</sub></sub> = 165 μA  | COM <sub>SATO</sub> | V <sub>COM<sub>SATO</sub></sub>   | 0                      |      | 0.3              | V        | A     |
| 11.24                  | Output voltage high at pin COM <sub>COO</sub>   | I <sub>COM<sub>COO</sub></sub> = -85 μA  | COM <sub>SATO</sub> | V <sub>COM<sub>SATO</sub></sub>   | V <sub>INT</sub> - 0.6 |      | V <sub>INT</sub> | V        | A     |

\*) Type means: A = 100% tested, B = 100% correlation tested, C = Characterized on samples, D = Design parameter

- Notes:
1. Depending on implementation of slope compensation, sub-harmonics have to be prevented.
  2. The value of the minimum load current must be higher than the internal pull-up current at pin V<sub>CORE</sub> to ensure proper function of the regulator.

**Table 12-1. Electrical Characteristics (Continued)– V<sub>CORE</sub> Power Supply**

| No.   | Parameters  | Test Conditions   | Pin               | Symbol              | Min               | Typ. | Max.               | Unit        | Type* |
|-------|---|---|-------------------|---------------------|-------------------|------|--------------------|-------------|-------|
| 11.25 | Leading-edge blanking time  |   |                   | $t_{\text{blank}}$  | 150               |      | 200                | ns          | D     |
| 11.26 | Slope of artificial ramp for slope compensation   |   |                   | dV/dt               | 80 <sup>(1)</sup> |      | 150 <sup>(1)</sup> | mV/ $\mu$ s | D     |
| 11.27 | Voltage level at K30 to switch V <sub>CORE</sub> supply from EVZ to K30 (V <sub>V<sub>CORE</sub></sub> = 1.8V or 2.5V programmed) | V <sub>K30</sub> increasing<br>See number 7.3 of <a href="#">Table 8-2 on page 23</a> |                   |                     |                   |      |                    |             | A     |
| 11.28 | Hysteresis at K30 to switch V <sub>CORE</sub> supply from K30 to EVZ (V <sub>V<sub>CORE</sub></sub> = 1.8V or 2.5V programmed)    | V <sub>K30</sub> decreasing<br>See number 7.4 of <a href="#">Table 8-2 on page 23</a> |                   |                     |                   |      |                    |             | A     |
| 11.29 | Voltage level at K30 to switch V <sub>CORE</sub> supply from EVZ to K30 (V <sub>V<sub>CORE</sub></sub> = 5V programmed)           | V <sub>K30</sub> increasing   | K30               | V <sub>K30</sub>    | 6.1               |      | 8.1                | V           | A     |
| 11.30 | Hysteresis at K30 to switch V <sub>CORE</sub> supply from K30 to EVZ (V <sub>V<sub>CORE</sub></sub> = 5V programmed)              | V <sub>K30</sub> decreasing   | K30               | V <sub>K30</sub>    | 0.5               |      | 1                  | V           | A     |
| 11.31 | Time to switch V <sub>CORE</sub> supply from EVZ to K30 or K30 to EVZ   |   | SVCORE            | $t_{\text{switch}}$ | 0                 |      | 7.6                | $\mu$ s     | D     |
| 11.32 | V <sub>CORE</sub> loss-detection threshold <sup>(2)</sup>   |   | V <sub>CORE</sub> | I <sub>Load</sub>   | 0                 |      | 1                  | mA          | D     |

\*) Type means: A = 100% tested, B = 100% correlation tested, C = Characterized on samples, D = Design parameter

- Notes:
1. Depending on implementation of slope compensation, sub-harmonics have to be prevented.
  2. The value of the minimum load current must be higher than the internal pull-up current at pin V<sub>CORE</sub> to ensure proper function of the regulator.

### 13. USP Comparator for General Purpose

The USP comparator is used for general purposes, for example, low battery detection. An external resistive voltage divider provides the input signal for pin USP. A missing USP connection or  $V_{USP} < 2.44V$  sets the status register bit b7 to low. During normal operation ( $V_{USP} > 2.44V$ ) the status register bit b7 stays high.

Figure 13-1. Functional Principle of the USP Comparator

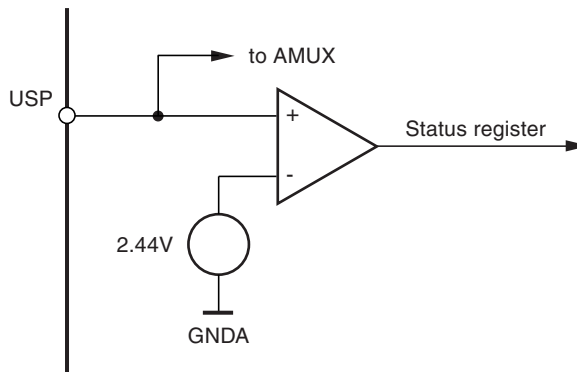

Necessary for operation:

$V_{EVZ} = 5.5V$  to  $40V$ ,  $V_{PERI} >$  reset threshold,  $V_{CORE} >$  reset threshold,  $V_{INT} = 3.7V$  to  $5.47V$

Operating conditions of all other supply pins:

$V_{SAT}$  and  $V_{K30}$  are within functional range limits,  $T_j = -40^{\circ}C$  to  $150^{\circ}C$

Other pins:

As defined in [Section 4. "Functional Range" on page 8.](#)

Table 13-1. Electrical Characteristics – USP Comparator for General Purpose

| No.  | Parameters                   | Test Conditions   | Pin | Symbol         | Min           | Typ. | Max. | Unit    | Type* |
|------|------------------------------|---|-----|----------------|---------------|------|------|---------|-------|
| 12.1 | Input current at pin USP     | $V_{USP} = 2.44V$   | USP | $I_{USP}$      | -2.5          |      | +2.5 | $\mu A$ | A     |
| 12.2 | Input current at pin USP     | $V_{USP} = 0$ to $40V$  | USP | $I_{USP}$      | -2.5          |      | +2.5 | $\mu A$ | A     |
| 12.3 | Threshold voltage at pin USP | Trigger voltage for status register bit 7= high with increasing $V_{USP}$ | USP | $V_{USP}$      | 2.44 $\pm$ 5% |      |      | V       | A     |
| 12.4 | De-glitching time            |   |     | $t_{deglitch}$ | 20            |      | 60   | $\mu s$ | D     |

\*) Type means: A = 100% tested, B = 100% correlation tested, C = Characterized on samples, D = Design parameter

## 14. Reference Voltage and Reference Current Generation

The pin IREF is an output derived directly from the chip's internal reference voltage. This reference source is a band gap. All internally used precise voltages are derived from this band-gap voltage. At pin IREF a reference resistor of 12.4 kΩ has to be applied, providing a reference current. All internally used precise currents are derived from this current. In case of a missing resistor at IREF, the regulators will stop. The power-sequencing block still operates as specified.

A defect of the band-gap reference source can be detected by a microcontroller by comparing the voltage at IREF with the voltage at pin VINT (Internal 5V supply), because  $V_{VINT}$  is derived from a different band gap.

**Table 14-1.** Truth Table for VINT

| State | K30GOOD<br>( $V_{K30} > 4.2V$ to 5V) | K15GOOD<br>( $V_{K15} > 3V$ to 4V) | $V_{EVZ}$           | $V_{VINT}$   |
|-------|--------------------------------------|------------------------------------|---------------------|--|
| 1     | Low                                  | Low                                | 0                   | OFF  |
| 2     | High                                 | Low                                | 0                   | OFF  |
| 3     | Low                                  | High                               | 0                   | OFF  |
| 4     | High                                 | High                               | $V_{EVZ} < V_{K30}$ | ON (Supply: K30)   |
| 5     | Low                                  | Low                                | $V_{EVZ} > 5.5V$    | ON (Supply: EVZ) – only valid if VINT was already enabled via state #4 |
| 6     | High                                 | Low                                | $V_{EVZ} > 5.5V$    | ON (Supply: EVZ) – only valid if VINT was already enabled via state #4 |
| 7     | Low                                  | High                               | $V_{EVZ} > 5.5V$    | ON (Supply: EVZ) – only valid if VINT was already enabled via state #4 |
| 8     | High                                 | High                               | $V_{EVZ} > V_{K30}$ | ON (Supply: K30)   |

Necessary for operation:

$$V_{EVZ} = 5.5V \text{ to } 40V \text{ or } V_{K30} = 3.85V \text{ to } 40V$$

Operating conditions of all other supply pins:

$$V_{SAT}, V_{PERI} \text{ and } V_{CORE} \text{ are within functional range limits, } T_j = -40^{\circ}C \text{ to } +150^{\circ}C$$

Other pins:

As defined in [Section 4. "Functional Range" on page 8](#).

**Table 14-2.** Electrical Characteristics – Reference Voltage and Reference Current Generation

| No.   | Parameters                   | Test Conditions  | Pin  | Symbol     | Min       | Typ. | Max. | Unit | Type* |
|-------|------------------------------|--|------|------------|-----------|------|------|------|-------|
| 13.1  | Reference voltage $V_{IREF}$ |  | IREF | $V_{IREF}$ | 1.24 ± 4% |      |      | V    | A     |
| 13.2  | Reference current IREF       |  | IREF | $I_{IREF}$ | 100 ± 4%  |      |      | μA   | A     |
| 13.3a | Voltage at VINT              | $V_{K30} > V_{EVZ}$<br>$V_{K30} = VK30GOOD$ to 5V      | VINT | $V_{VINT}$ | 3.35      |      | 5.47 | V    | A     |
| 13.3b | Voltage at VINT              | $V_{K30} > V_{EVZ}$ , $V_{K30} = 5V$ to 6V             | VINT | $V_{VINT}$ | 3.7       |      | 5.47 | V    | A     |
| 13.3c | Voltage at VINT              | $V_{K30} > V_{EVZ}$ , $V_{K30} = 6V$                   | IREF | $V_{IREF}$ | 4.2       |      | 5.47 | V    | A     |
| 13.3d | Voltage at VINT              | $V_{EVZ} > V_{K30}$<br>$V_{K30} = 0V$ , $V_{EVZ} > 6V$ | IREF | $V_{IREF}$ | 4.2       |      | 5.47 | V    | A     |

\*) Type means: A = 100% tested, B = 100% correlation tested, C = Characterized on samples, D = Design parameter



## 15. Reset Function (Pin RESQ and Pin RESQ2)

Pins RESQ and RESQ2 are low-active digital outputs of the ATA6264, which provide a digital “low” signal in the case of a missing or incorrect watchdog transmission or in the case of improper VEZ, VPERI or VCORE voltage.

The voltage at pin RESQ depends on the proper voltages at pins EVZ, VCORE, and VPERI. The RESQ signal will be set to high after a 16-ms delay as soon as the VCORE reset threshold and the VPERI reset threshold and the EVZ reset threshold (signal EVZGOOD = high) have been reached. If the watchdog circuitry does not detect a valid watchdog trigger, the RESQ signal is set to low again. If the watchdog was triggered successfully, RESQ stays high and RESQ2 is also set to high.

In the case that an overvoltage at VCORE or VPERI is detected, the voltages at pins RESQ and RESQ2 are set to low.

**Figure 15-1.** Functional Principle of RESQ, RESQ2

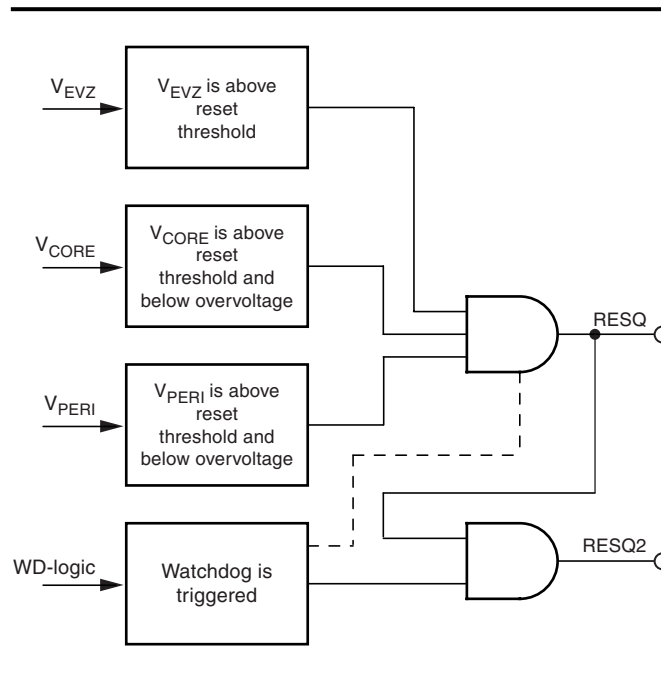

**Figure 15-2.** Functional Principle of RESQ, RESQ2

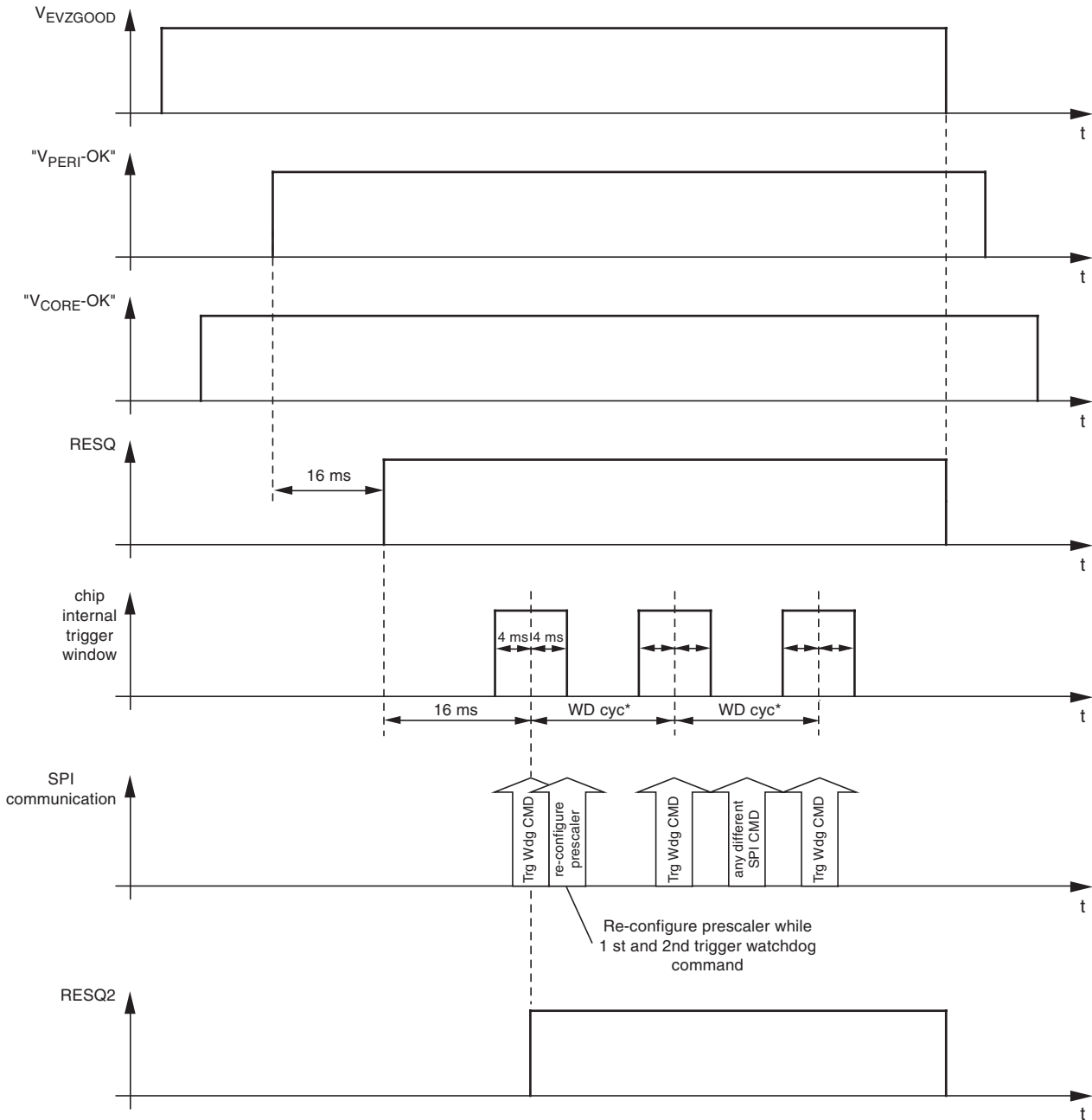

\* Watchdog cycle, see pages 48 and 49

The RESQ2 signal results from a logical AND of the Reset signal and an OK signal from the watchdog circuitry, so RESQ2 will go high after the watchdog triggers correctly.

RESQ and RESQ2 have to be set to low if  $V_{VPERI}$  or  $V_{EVZ}$  are below the specified threshold. V<sub>CORE</sub> is designed as an essential supply for a microcontroller core, and therefore special *supervisor circuits* for this regulator will affect the signals at pin RESQ and RESQ2 such that both outputs are set to low if the voltage at pin V<sub>CORE</sub> spends more than 4 regulator cycles in an overvoltage or undervoltage condition at their corresponding switching marks. In addition, a detected overcurrent signal during switch-on gives information about regulator problems, and results in a low-level signal for RESQ/RESQ2.

**Figure 15-3.** Functional Principle of the Supervisor Circuit for V<sub>CORE</sub> Monitoring (Values are Valid for  $V_{VPERI} = 1.88V$  and  $V_{VPERI} = 3.3V$ )

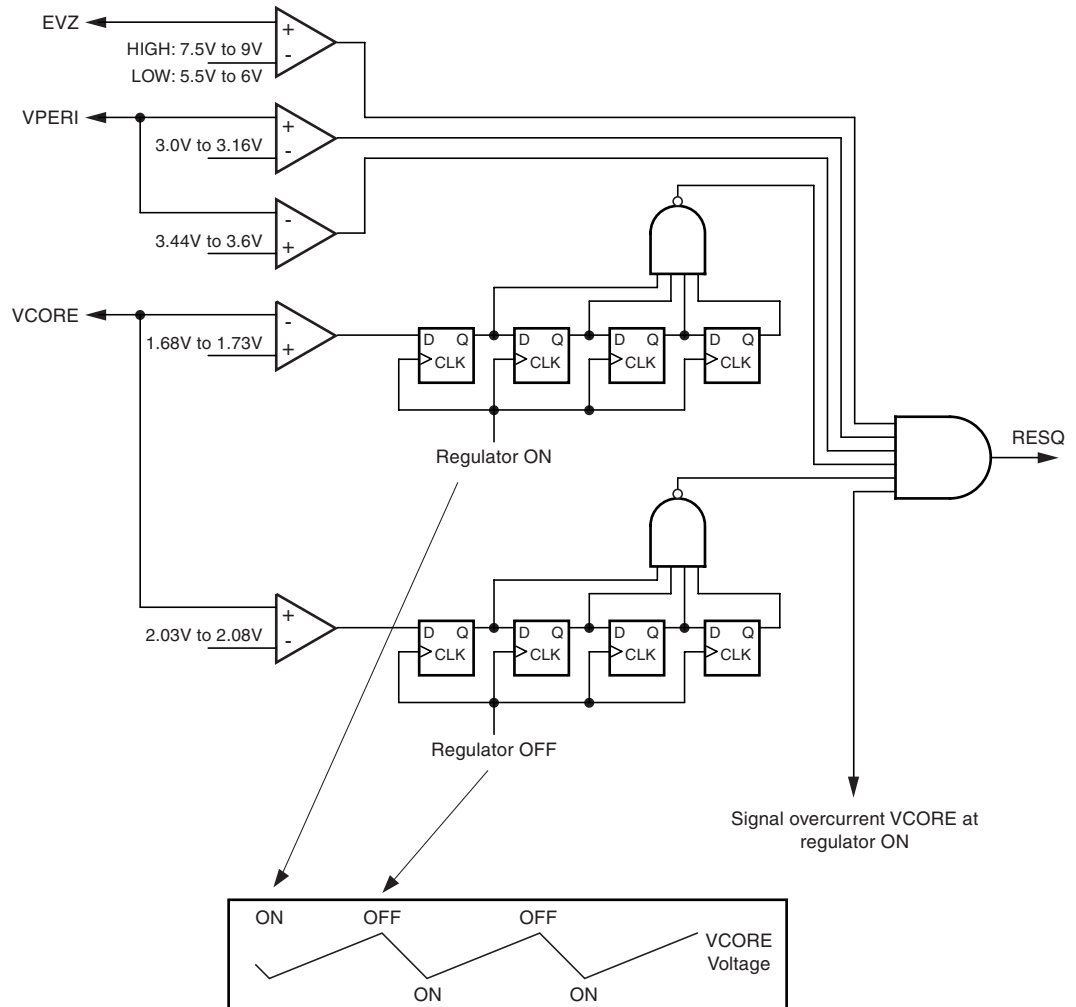

If the watchdog is triggered incorrectly, RESQ and RESQ2 are set to low as well. Voltage spikes on EVZ smaller than or equal to 10  $\mu$ s to 20  $\mu$ s do not influence the RESQ or RESQ2 pins.

If the ATA6264 internal supply voltage (V<sub>INT</sub>) is below its proper value, RESQ and RESQ2 are also set to low.

For all voltages at V<sub>PERI</sub> below the reset threshold, pins RESQ and RESQ2 are switched to low. Both pins deliver a valid low until V<sub>PERI</sub> goes lower than 1V.

**Table 15-1.** Reset Truth Table

| VPERI                  | VCORE                       | VEVZ  | WATCHDOG  | RESQ                         | RESQ2                        |
|------------------------|-----------------------------|---|---|------------------------------|------------------------------|
| < 1V                   | X                           | X   | X   | Undefined (low via resistor) | Undefined (low via resistor) |
| 1V to $V_{VPERI} = OK$ | X                           | X   | X   | Low                          | Low                          |
| > $V_{VPERI} = OK$     | $V_{VCORE} = \text{Not OK}$ | X   | X   | Low                          | Low                          |
|                        | $V_{VCORE} = OK$            | EVZGOOD = high ( $V_{EVZ} = OK$ )           | After startup (no trigger has occurred)                     | High                         | Low                          |
|                        |                             |   | Correctly triggered (trigger occurred 1 <sup>st</sup> time) | High                         | Low -> high                  |
|                        |                             |   | Correctly triggered   | High                         | High                         |
|                        | Incorrectly triggered       | High -> low                                 | High -> low   |                              |                              |
| X                      | $V_{VCORE} = \text{Not OK}$ | EVZGOOD = low ( $V_{EVZ} = \text{Not OK}$ ) | X   | Low                          | Low                          |

**Figure 15-4.** Application Example

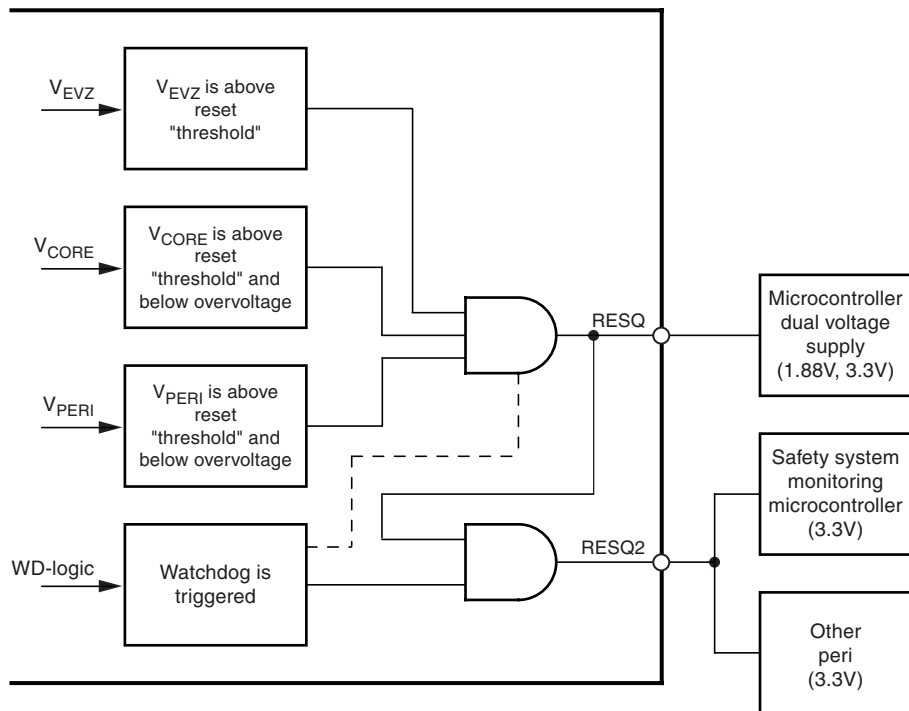

Necessary for operation:

$V_{EVZ} = 5.5V$  to  $40V$ ,  $V_{PERI} = 1V$  to  $5.5V$ ,  $V_{INT} = 3.7V$  to  $5.47V$

Operating conditions of all other supply pins:

$V_{K30}$ ,  $V_{SAT}$ , and  $V_{CORE}$  are within functional range limits,  $T_j = -40^{\circ}C$  to  $150^{\circ}C$

Other pins:

As defined in [Section 4. "Functional Range" on page 8.](#)

Table 15-2. Electrical Characteristics – Reset Function (Pin RESQ and Pin RESQ2)

| No.   | Parameters   | Test Conditions                                 | Pin           | Symbol                    | Min               | Typ. | Max.        | Unit | Type* |
|-------|--|---|---------------|---------------------------|-------------------|------|-------------|------|-------|
| 14.1  | RESQ and RESQ2 high level  | $I_{RESQ}, I_{RESQ2} = -200 \mu A$ to $0 \mu A$ | RESQ<br>RESQ2 | $V_{RESQ}$<br>$V_{RESQ2}$ | $V_{VPERI} - 0.8$ |      | $V_{VPERI}$ | V    | A     |
| 14.2  | RESQ and RESQ2 low level   | $I_{RESQ}, I_{RESQ2} = 0$ mA to 2 mA            | RESQ<br>RESQ2 | $V_{RESQ}$<br>$V_{RESQ2}$ | 0                 |      | 0.4         | V    | A     |
| 14.3  | Reset threshold at pin V <sub>CORE</sub>   | $V_{VCORE}$ is set to 5V                        | VCORE         | $V_{VCORE}$               | 4.5               |      | 5.03        | V    | A     |
| 14.3a | Voltage difference<br>$V_{VCORE}$ – reset threshold at V <sub>CORE</sub> (see number 14.3) | $V_{VCORE}$ is set to 5V                        | VCORE         | $dV_{VCORE}$              | 0.17              |      | 0.7         | V    | A     |
| 14.4  | Reset threshold at pin V <sub>CORE</sub>   | $V_{VCORE}$ is set to 2.5V                      | VCORE         | $V_{VCORE}$               | 2.25              |      | 2.5         | V    | A     |
| 14.4a | Voltage difference<br>$V_{VCORE}$ – reset threshold at V <sub>CORE</sub> (see number 14.4) | $V_{VCORE}$ is set to 2.5V                      | VCORE         | $dV_{VCORE}$              | 0.1               |      | 0.35        | V    | A     |
| 14.5  | Reset threshold at pin V <sub>CORE</sub>   | $V_{VCORE}$ is set to 1.88V                     | VCORE         | $V_{VCORE}$               | 1.68              |      | 1.8852      | V    | A     |
| 14.5a | Voltage difference<br>$V_{VCORE}$ – reset threshold at V <sub>CORE</sub> (see number 14.5) | $V_{VCORE}$ is set to 1.88V                     | VCORE         | $dV_{VCORE}$              | 0.07              |      | 0.275       | V    | A     |
| 14.6  | Overvoltage at pin V <sub>CORE</sub> to switch off the regulator and set RESQ to low       | $V_{VCORE}$ is set to 5V                        | VCORE         | $V_{VCORE}$               | 4.97              |      | 5.5         | V    | A     |
| 14.6a | Voltage difference reset threshold at V <sub>CORE</sub> (see number 14.6) – $V_{VCORE}$    | $V_{VCORE}$ is set to 5V                        | VCORE         | $dV_{VCORE}$              | 0.17              |      | 0.7         | V    | A     |
| 14.7  | Overvoltage at pin V <sub>CORE</sub> to switch off the regulator and set RESQ to low       | $V_{VCORE}$ is set to 2.5V                      | VCORE         | $V_{VCORE}$               | 2.5               |      | 2.8         | V    | A     |
| 14.7a | Voltage difference reset threshold at V <sub>CORE</sub> (see number 14.7) – $V_{VCORE}$    | $V_{VCORE}$ is set to 2.5V                      | VCORE         | $dV_{VCORE}$              | 0.1               |      | 0.35        | V    | A     |
| 14.8  | Overvoltage at pin V <sub>CORE</sub> to switch off the regulator and set RESQ to low       | $V_{VCORE}$ is set to 1.88V                     | VCORE         | $V_{VCORE}$               | 1.8748            |      | 2.11        | V    | A     |
| 14.8a | Voltage difference reset threshold at V <sub>CORE</sub> (see number 14.8) – $V_{VCORE}$    | $V_{VCORE}$ is set to 1.88V                     | VCORE         | $dV_{VCORE}$              | 0.07              |      | 0.275       | V    | A     |
| 14.9  | Reset threshold at pin V <sub>PERI</sub>   | $V_{VPERI}$ is set to 5V                        | VPERI         | $V_{VPERI}$               | 4.5               |      | 4.82        | V    | A     |
| 14.10 | Reset threshold at pin V <sub>PERI</sub>   | $V_{VPERI}$ is set to 3.3V                      | VPERI         | $V_{VPERI}$               | 2.94              |      | 3.16        | V    | A     |
| 14.11 | Overvoltage at pin V <sub>PERI</sub> to set RESQ to low                                    | $V_{VPERI}$ is set to 5V                        | VPERI         | $V_{VPERI}$               | 5.2               |      | 5.51        | V    | A     |
| 14.12 | Overvoltage at pin V <sub>PERI</sub> to set RESQ to low                                    | $V_{VPERI}$ is set to 3.3V                      | VPERI         | $V_{VPERI}$               | 3.4               |      | 3.63        | V    | A     |
| 14.13 | Threshold for signal EVZGOOD = OK  | $V_{EVZ}$ rising                                | EVZ           | $V_{EVZ}$                 | 7.5               |      | 9           | V    | A     |
| 14.14 | Threshold for signal EVZGOOD = Not OK  | $V_{EVZ}$ falling                               | EVZ           | $V_{EVZ}$                 | 5.5               |      | 6.2         | V    | A     |

\*) Type means: A = 100% tested, B = 100% correlation tested, C = Characterized on samples, D = Design parameter

**Table 15-2. Electrical Characteristics (Continued)– Reset Function (Pin RESQ and Pin RESQ2)**

| No.   | Parameters   | Test Conditions   | Pin           | Symbol                    | Min  | Typ. | Max. | Unit       | Type* |
|-------|--|---|---------------|---------------------------|------|------|------|------------|-------|
| 14.15 | Delay time for RESQ and RESQ2 to switch to low after reaching the reset threshold of $V_{EVZ}$ |   | RESQ<br>RESQ2 | $t_{RESQ}$<br>$t_{RESQ2}$ | 10   |      | 20   | $\mu s$    | A     |
| 14.16 | Pull-down current at pin RESQ  | RESQ is switched to low ( $V_{RESQ} = 0.4V$ ),<br>$1V \leq V_{VPERI} < 5.5V$  | RESQ          | $I_{RESQ}$                | 1    |      | 2    | mA         | A     |
| 14.17 | Pull-down current at pin RESQ2   | RESQ2 is switched to low ( $V_{RESQ} = 0.4V$ ),<br>$1V \leq V_{VPERI} < 5.5V$ | RESQ2         | $I_{RESQ2}$               | 1    |      | 2    | mA         | A     |
| 14.18 | Pull-down resistor at pin RESQ, RESQ2  |   | RESQ<br>RESQ2 | $R_{RESQ}$<br>$R_{RESQ2}$ | 0.5  |      | 1.5  | M $\Omega$ | D     |
| 14.19 | Output current high side RESQ, RESQ2   | RESQ, RESQ2 are switched to high,<br>$V_{RESQ}, V_{RESQ2} = 0V$               | RESQ<br>RESQ2 | $I_{RESQ}$<br>$I_{RESQ2}$ | -550 |      | -250 | $\mu A$    | A     |
| 14.20 | Output current low side RESQ, RESQ2  | RESQ, RESQ2 are switched to high,<br>$V_{RESQ}, V_{RESQ2} = V_{VPERI}$        | RESQ<br>RESQ2 | $I_{RESQ}$<br>$I_{RESQ2}$ | 4    |      | 10   | mA         | A     |
| 14.21 | Rise time RESQ, RESQ2  | 30-pF external capacitive load  | RESQ<br>RESQ2 | $t_{RESQ}$<br>$t_{RESQ2}$ |      |      | 4.0  | $\mu s$    | A     |
| 14.22 | Fall time RESQ, RESQ2  | 30-pF external capacitive load  | RESQ<br>RESQ2 | $t_{RESQ}$<br>$t_{RESQ2}$ |      |      | 0.5  | $\mu s$    | A     |

\*) Type means: A = 100% tested, B = 100% correlation tested, C = Characterized on samples, D = Design parameter

## 16. Watchdog Function

To verify the proper function of the microcontroller, watchdog logic is included. As the ATA6264 is powered up, the RESQ2 signal stays low until the first valid watchdog trigger is detected.

Features:

- Watchdog trigger has to be done via the serial interface
- In case of a watchdog-trigger mismatch, the ATA6264 is set into its default state (latches, MISO status, etc.) and RESQ is set to low.
- Watchdog has to be triggered cyclically (prescaler for repetition time is set via serial interface command). Default: 16-ms repetition time

Figure 16-1. Watchdog Trigger Functional Principle

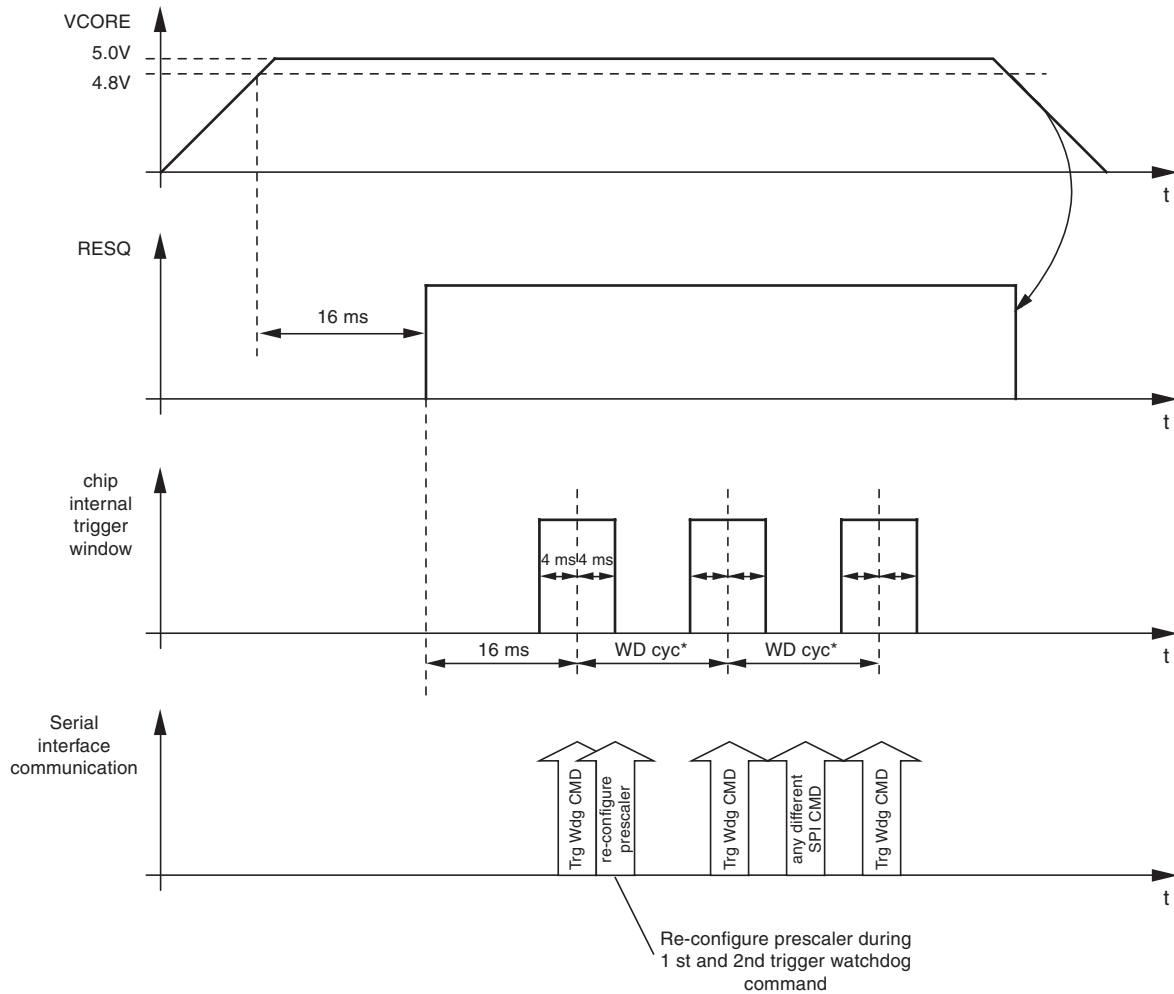

\* Watchdog cycle, see pages 48 and 49

Requirements for successful trigger:

- Minimum one valid different serial interface command between two trigger watchdog commands is necessary. Exception: First trigger watchdog command need not be preceded by a different serial interface command.
- Cyclic repetition for the trigger watchdog command within  $\pm 25\%$  tolerance is necessary.

Incorrect trigger causes RESQ active.

The prescaler will be set to its default value with RESQ = low

Initial phase:

Timing for the first trigger watchdog is fixed to 16 ms after RESQ changes from low to high (trigger window  $\pm 25\%$  means  $\pm 4$ -ms trigger window for first trigger watchdog command). After the first watchdog trigger, the prescaler can be reconfigured within a specified time window ( $< 1$  ms). Only one configuration command is allowed in this time window. For watchdog trigger handling, the Serial Interface Reconfigure command can be chosen as a different serial interface command. Any further configuration inside or outside this time window will cause an immediate reset via RESQ.

**Figure 16-2.** Reconfiguration Prescaler Functional Principle

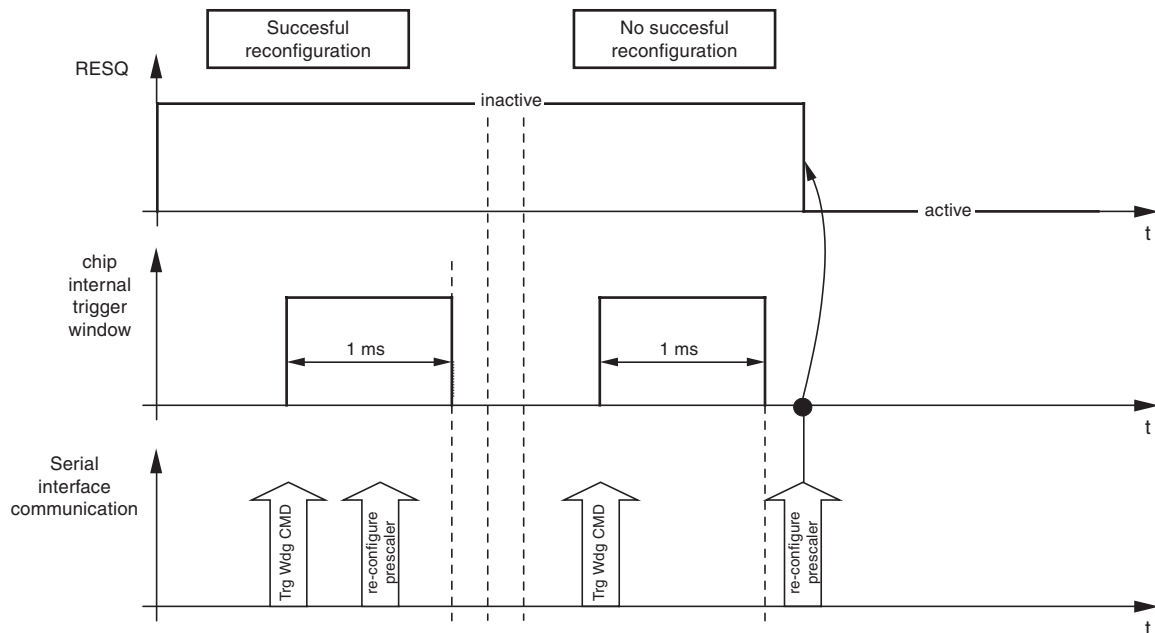



The trigger watchdog cycle can be set to the following retrigger times:

- 4 ms
- 8 ms
- 16 ms (default)
- 32 ms
- 64 ms
- 128 ms

Cyclic phase:

Between two trigger commands a different SPI command must be seen by the SPI decoder

**Figure 16-3.** Watchdog Trigger Functional Principle (Successful Watchdog Trigger)

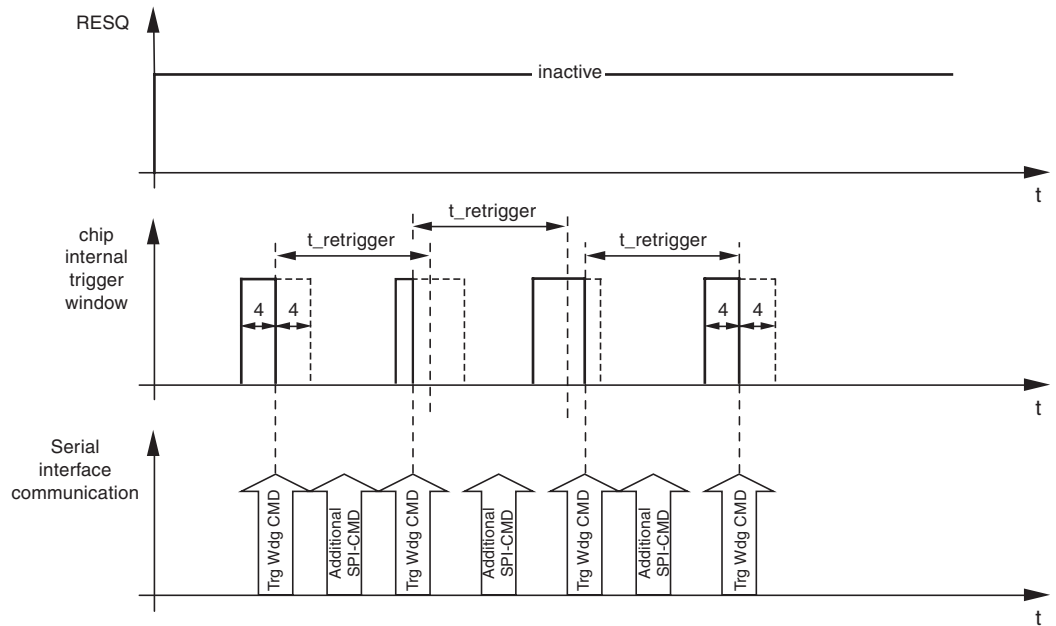

**Figure 16-4.** Watchdog Trigger Functional Principle (Unsuccessful Watchdog Trigger)

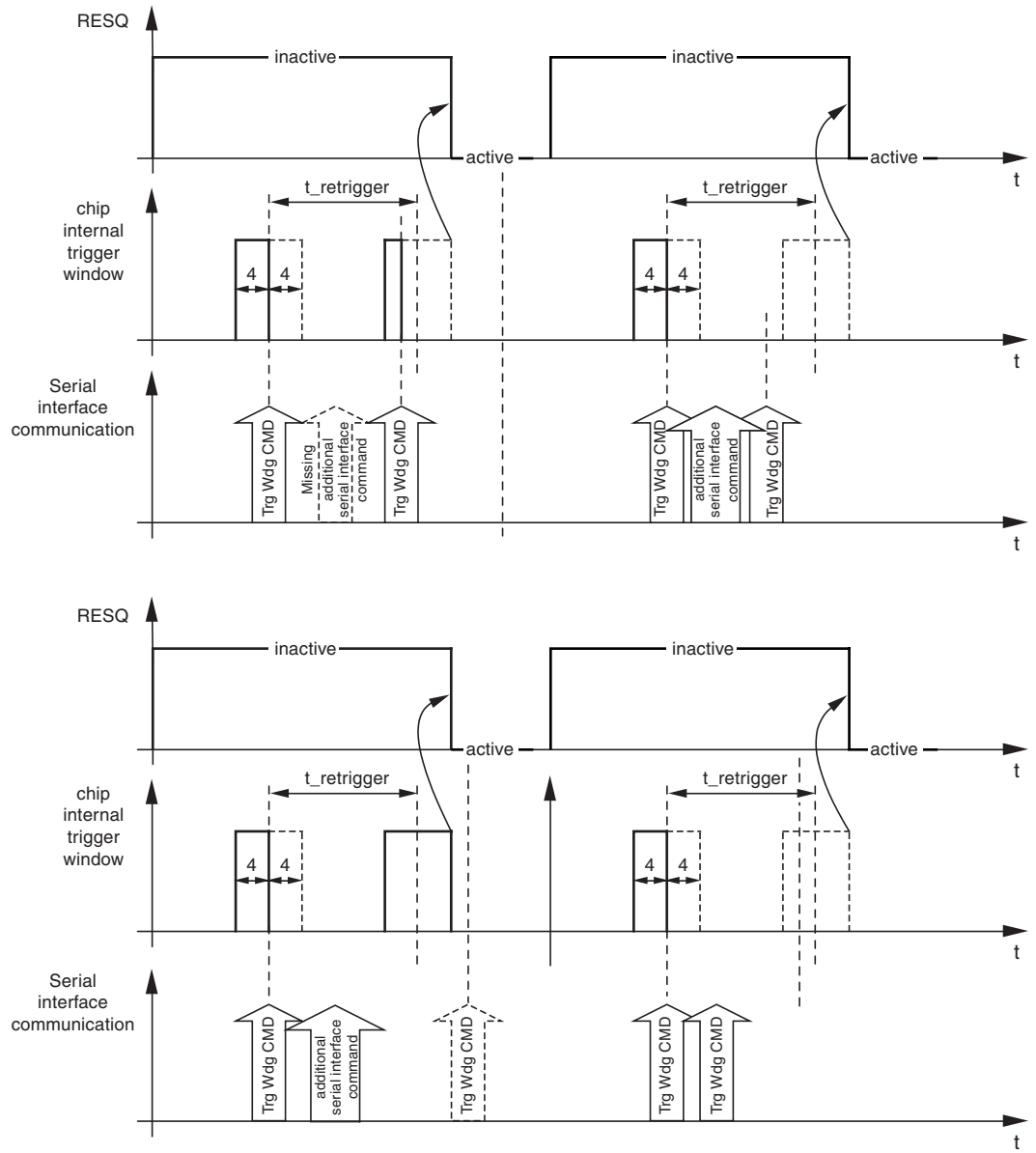

Configuration of watchdog trigger:

For the configuration of the watchdog prescaler, a special serial interface command is necessary.

| Description         | MSByte |   |   |   |   |   |   |   | LSByte |   |   |   |   |   |   |   | Hex Code |
|---------------------|--------|---|---|---|---|---|---|---|--------|---|---|---|---|---|---|---|----------|
|                     | 7      | 6 | 5 | 4 | 3 | 2 | 1 | 0 | 7      | 6 | 5 | 4 | 3 | 2 | 1 | 0 |          |
| Configure prescaler | 0      | 1 | 1 | 0 | 0 | 0 | 0 | 0 | 1      | 1 | 1 | 1 | 0 | a | b | c | 60Fx     |

Note: a, b, and c to be set as defined in [Table 16-1](#)

**Table 16-1.** Watchdog Prescaler Command

| Selection Bits |   |   | Retrigger Time (ms)    |
|----------------|---|---|------------------------|
| a              | b | c |                        |
| 0              | 0 | 0 | Set to default (16 ms) |
| 0              | 0 | 1 | 4                      |
| 0              | 1 | 0 | 8                      |
| 0              | 1 | 1 | 16                     |
| 1              | 0 | 0 | 32                     |
| 1              | 0 | 1 | 64                     |
| 1              | 1 | 0 | 128                    |
| 1              | 1 | 1 | Set to default (16 ms) |

The status of the watchdog prescaler is indicated in the status register.

Necessary for operation:

$V_{PERI} > \text{Reset threshold}$ ,  $V_{CORE} > \text{Reset threshold}$

Operating conditions of all other supply pins:

$V_{K30}$ ,  $V_{EVZ}$  and  $V_{VSAT}$  are within functional range limits,  $T_j = -40^{\circ}\text{C}$  to  $150^{\circ}\text{C}$

Other pins:

As defined in [Section 4. "Functional Range" on page 8](#).

**Table 16-2.** Electrical Characteristics – Watchdog Function

| No.  | Parameters  | Test Conditions                              | Pin  | Symbol     | Min                  | Typ. | Max.                 | Unit                 | Type* |
|------|---|--|------|------------|----------------------|------|----------------------|----------------------|-------|
| 15.1 | Oscillator frequency  |  |      | $f_{os}$   | -5%                  | 100  | +5%                  | kHz                  | A     |
| 15.2 | Power-up extension of RESQ signal   |  | RESQ | $t_{RESQ}$ | 16                   |      | 16                   | $\frac{100}{f_{os}}$ | A     |
| 15.3 | Start of first watchdog trigger window after rising edge at RESQ              |  |      | t          | 12                   |      | 12                   | $\frac{100}{f_{os}}$ | A     |
| 15.4 | Maximum width of first watchdog-trigger window                                |  |      | t          | 8                    |      | 8                    | $\frac{100}{f_{os}}$ | A     |
| 15.5 | Maximum time for prescaler configuration after first watchdog-trigger command |  |      | t          | 1                    |      | 1                    | $\frac{100}{f_{os}}$ | A     |
| 15.6 | Programmed watchdog cycle   | $t_{WD}$ as set by prescaler (default 16 ms) |      |            | $t_{WD}$             |      | $t_{WD}$             |                      | A     |
| 15.7 | Start of programmed watchdog window   |  |      |            | $75\% \times t_{WD}$ |      | $75\% \times t_{WD}$ |                      | A     |
| 15.8 | Max. programmed window duration   |  |      |            | $50\% \times t_{WD}$ |      | $50\% \times t_{WD}$ |                      | A     |
| 15.9 | Time for RESQ = low after watchdog timeout                                    | (Missing watchdog trigger)                   | RESQ | t          | 16                   |      | 16                   | $\frac{100}{f_{os}}$ | A     |

\*) Type means: A = 100% tested, B = 100% correlation tested, C = Characterized on samples, D = Design parameter

Figure 16-5. Watchdog Trigger

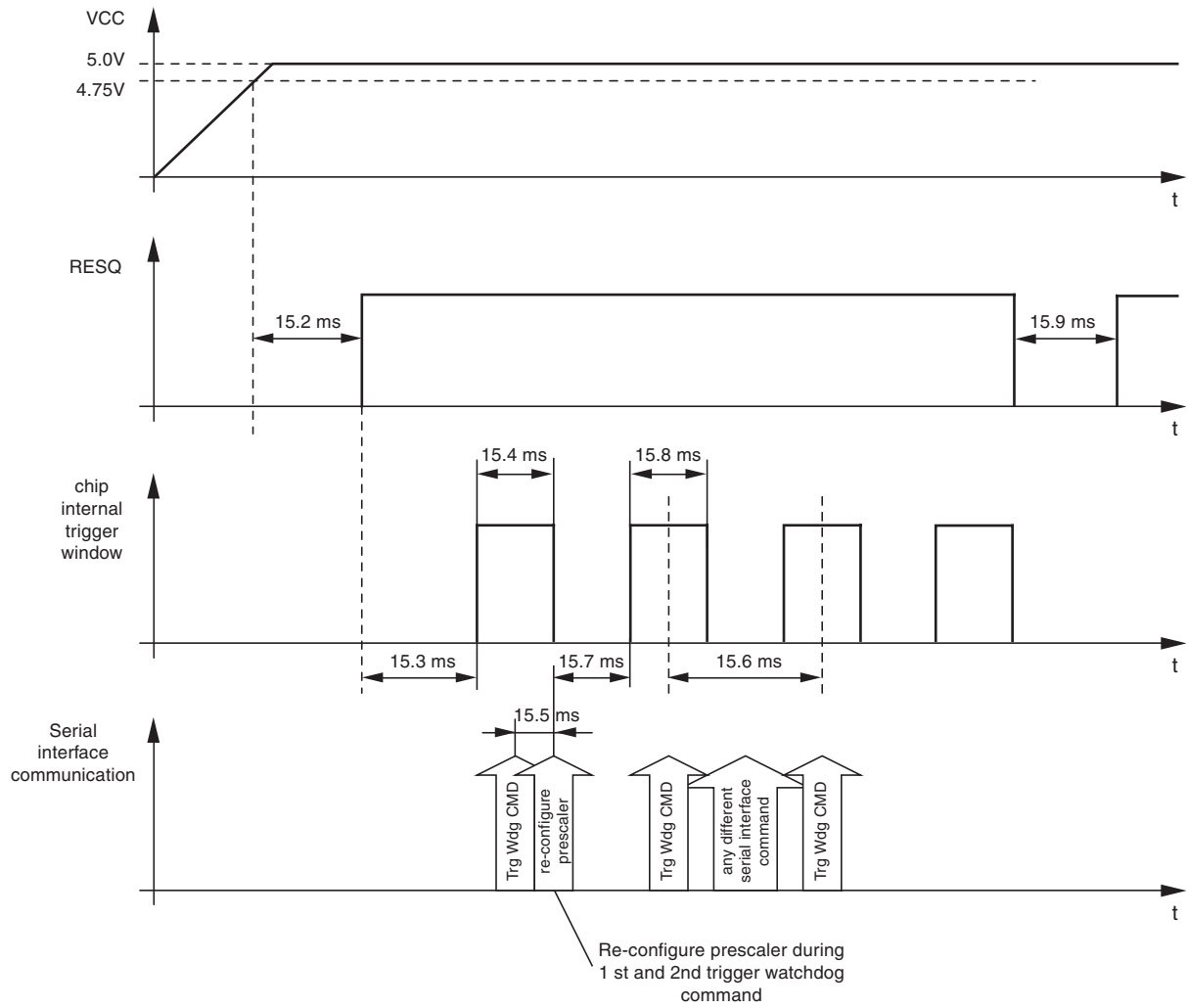

## 17. LIN/ISO 9141 Interfaces

The ATA6264 includes two complete ISO 9141 interfaces. Interface #1 is controlled via the pins RxD1 and TxD1, interface #2 is controlled via the pins RxD2 and TxD2. In order to support both ISO9141 and LIN bus requirements, interface #1 can be configured during initial programming. In applications where one or both ISO9141 interfaces are not needed, the output transistors of K1 and K2 may be used as simple low-side transistors, switched on or off by the serial interface. In this mode, a diagnosis of the pins K1 and K2 via the analog multiplexer is possible. The K1 and K2 outputs include an internal current limitation and overtemperature protection circuit.

**Figure 17-1.** Functional Principle of the LIN/ISO 9141 Interfaces

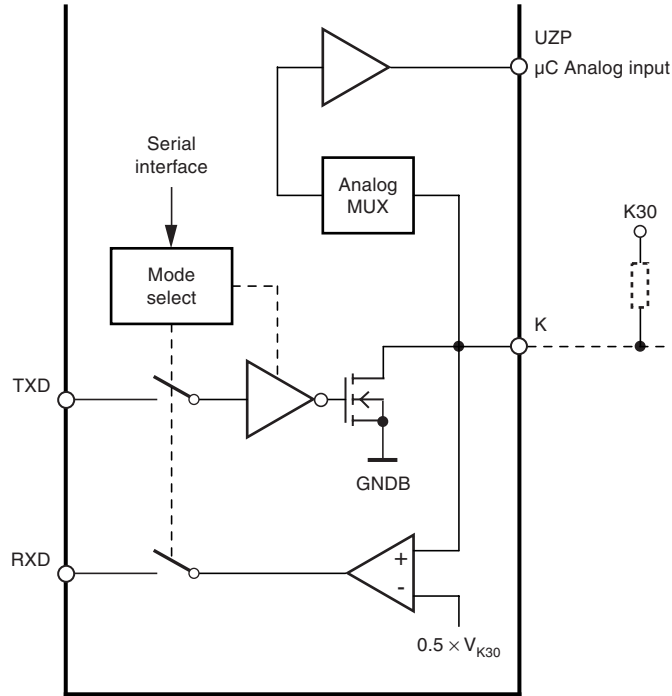

Necessary for operation:

$V_{EVZ} = 9V$  to  $40V$ ,  $V_{K30} = 5.5V$  to  $40V$ ,  $V_{VPERI} >$  Reset threshold,  $V_{VCORE} >$  Reset threshold,  $V_{VINT} = 3.7V$  to  $5.47V$

Operating conditions of all other supply pins:

$V_{VSAT}$  is within functional range limits,  $T_j = -40^{\circ}C$  to  $+150^{\circ}C$

Other pins:

As defined in [Section 4. "Functional Range" on page 8.](#)

Table 17-1. Electrical Characteristics – LIN/ISO 9141 Interfaces

| No.                                  | Parameters   | Test Conditions   | Pin              | Symbol            | Min                         | Typ.                 | Max.                         | Unit | Type* |
|--------------------------------------|--|---|------------------|-------------------|-----------------------------|----------------------|------------------------------|------|-------|
| <b>General (Valid for All Modes)</b> |  |   |                  |                   |                             |                      |                              |      |       |
| 16.1                                 | Pull-up current to VPERI at pin TxD <sub>x</sub>       | (x = 1, 2)  | TxD <sub>x</sub> | I <sub>TxDx</sub> | -35                         | -50                  | -65                          | μA   | A     |
| 16.2                                 | K <sub>x</sub> input receiver low                      | (x = 1, 2)  | K <sub>x</sub>   | V <sub>Kx</sub>   | 0                           |                      | 0.4 × V <sub>K30</sub>       | V    | A     |
| 16.3                                 | K <sub>x</sub> input receiver high                     | (x = 1, 2)  | K <sub>x</sub>   | V <sub>Kx</sub>   | 0.6 × V <sub>K30</sub>      |                      | V <sub>K30</sub>             | V    | A     |
| 16.4                                 | K <sub>x</sub> input receiver threshold                | (x = 1, 2)  | K <sub>x</sub>   | V <sub>Kx</sub>   |                             | V <sub>K30</sub> / 2 |                              | V    | A     |
| 16.5                                 | K <sub>x</sub> input receiver hysteresis               | (x = 1, 2)  | K <sub>x</sub>   | V <sub>Kx</sub>   | 0.07 × V <sub>K30</sub>     |                      | 0.2 × V <sub>K30</sub>       | V    | A     |
| 16.6                                 | K <sub>x</sub> output sink current                     | (x = 1, 2),<br>K output voltage 1.5V                    | K <sub>x</sub>   | I <sub>Kx</sub>   | 35                          |                      |                              | mA   | A     |
| 16.7                                 | K <sub>x</sub> output voltage drop                     | (x = 1, 2),<br>I <sub>Kx</sub> = 0 mA to 40 mA          | K <sub>x</sub>   | V <sub>Kx</sub>   |                             |                      | 1.7                          | V    | A     |
| 16.8                                 | K <sub>x</sub> output capacitance                      | (x = 1, 2), capacitance<br>between Kx and GNDB          | K <sub>x</sub>   | C <sub>Kx</sub>   |                             |                      | 10                           | pF   | D     |
| 16.9                                 | K <sub>x</sub> output current limitation               | (x = 1, 2)  | K <sub>x</sub>   | I <sub>Kx</sub>   | 50                          |                      | 100                          | mA   | A     |
| 16.10                                | K <sub>x</sub> leakage current                         | (x = 1, 2), output driver<br>deactivated                | K <sub>x</sub>   | I <sub>Kx</sub>   | -10                         |                      | +10                          | μA   | A     |
| 16.11                                | RxD <sub>x</sub> voltage drop high side                | (x = 1, 2),<br>with I <sub>RxDx</sub> = 0 μA to -500 μA | RxD <sub>x</sub> | V <sub>RxDx</sub> | V <sub>VPERI</sub><br>- 0.8 |                      | V <sub>VPERI</sub>           | V    | A     |
| 16.12                                | RxD <sub>x</sub> voltage drop low side                 | (x = 1, 2),<br>I <sub>RxDx</sub> = 0 mA to 1mA          | RxD <sub>x</sub> | V <sub>RxDx</sub> | 0                           |                      | 0.4                          | V    | A     |
| 16.13                                | RxD <sub>x</sub> high-side output<br>current           | (x = 1, 2),<br>V <sub>RxDx</sub> = 0V                   | RxD <sub>x</sub> | I <sub>RxDx</sub> | -1.1                        |                      | -0.2                         | mA   | A     |
| 16.14                                | RxD <sub>x</sub> low-side output<br>current            | (x = 1, 2),<br>V <sub>RxDx</sub> = V <sub>VPERI</sub>   | RxD <sub>x</sub> | I <sub>RxDx</sub> | 1                           |                      | 4                            | mA   | A     |
| 16.15                                | RxD <sub>x</sub> output rise time                      | (x = 1, 2), 30-pF external<br>load                      | RxD <sub>x</sub> | t <sub>RxDx</sub> |                             |                      | 1                            | μs   | A     |
| 16.16                                | RxD <sub>x</sub> output fall time                      | (x = 1, 2), 30-pF external<br>load                      | RxD <sub>x</sub> | t <sub>RxDx</sub> |                             |                      | 1                            | μs   | A     |
| 16.17                                | TxD <sub>x</sub> input-voltage high-level<br>threshold | (V <sub>VPERI</sub> = 5V),<br>(x = 1, 2)                | TxD <sub>x</sub> | V <sub>TxDx</sub> | 0.5 × V <sub>VPERI</sub>    |                      | V <sub>VPERI</sub><br>+ 0.3V | V    | A     |
| 16.18                                | TxD <sub>x</sub> input-voltage high-level<br>threshold | (V <sub>VPERI</sub> = 3.3V),<br>(x = 1, 2)              | TxD <sub>x</sub> | V <sub>TxDx</sub> | 0.6 × V <sub>VPERI</sub>    |                      | V <sub>VPERI</sub> +<br>0.3V | V    | A     |
| 16.19                                | TxD <sub>x</sub> input-voltage low level               | (V <sub>VPERI</sub> = 3.3V),<br>(x = 1, 2)              | TxD <sub>x</sub> | V <sub>TxDx</sub> |                             |                      | 0.2 × V <sub>VPERI</sub>     | V    | A     |
| 16.20                                | TxD <sub>x</sub> input-voltage hysteresis              | (x = 1, 2)  | TxD <sub>x</sub> | V <sub>TxDx</sub> | 100                         |                      | 550                          | mV   | A     |
| 16.21                                | TxD <sub>x</sub> input capacitance                     | (x = 1, 2)  | TxD <sub>x</sub> | C <sub>TxDx</sub> |                             |                      | 5                            | pF   | D     |
| 16.22                                | K <sub>x</sub> thermal shutdown                        | (x = 1, 2)  |                  | T <sub>JKx</sub>  | 155                         |                      | 185                          | °C   | B     |
| 16.22a                               | K <sub>x</sub> thermal-shutdown<br>hysteresis          | (x=1, 2)  |                  | DT <sub>JKx</sub> | 5                           |                      | 25                           | K    | B     |

\*) Type means: A = 100% tested, B = 100% correlation tested, C = Characterized on samples, D = Design parameter

**Table 17-1. Electrical Characteristics (Continued)– LIN/ISO 9141 Interfaces**

| No.  | Parameters  | Test Conditions   | Pin            | Symbol               | Min  | Typ. | Max. | Unit | Type* |
|--|---|---|----------------|----------------------|------|------|------|------|-------|
| <b>ISO 9141 Mode</b>   |   |   |                |                      |      |      |      |      |       |
| 16.23  | Maximum baud rate   |   | K <sub>x</sub> | f <sub>Kx</sub>      | 62.5 |      |      | kBd  | A     |
| 16.24  | Propagation delay<br>TxD <sub>x</sub> = low to K <sub>x</sub> = low   | (x = 1, 2),<br>measured from TxD <sub>x</sub><br>H to L to K <sub>x</sub> = 0.9 × V <sub>K30</sub><br>R <sub>Kx</sub> = 510Ω to K30,<br>C <sub>Kx</sub> = 470 pF to GNDB  | K <sub>x</sub> | t <sub>PDIL</sub>    |      |      | 1    | μs   | A     |
| 16.25  | Propagation delay<br>TxD <sub>x</sub> = high to K <sub>x</sub> = high | (x = 1, 2),<br>measured from TxD <sub>x</sub><br>L to H to K <sub>x</sub> = 0.1 × V <sub>K30</sub><br>R <sub>Kx</sub> = 510Ω to K30,<br>C <sub>Kx</sub> = 470 pF to GNDB  | K <sub>x</sub> | t <sub>PDIH</sub>    |      |      | 1    | μs   | A     |
| 16.26  | K <sub>x</sub> rise time  | (x = 1, 2), measured from<br>0.1 × V <sub>K30</sub> to 0.9 × V <sub>K30</sub><br>R <sub>Kx</sub> = 510Ω to K30,<br>C <sub>Kx</sub> = 470 pF to GNDB                       | K <sub>x</sub> | t <sub>Krise</sub>   |      |      | 3    | μs   | A     |
| 16.27  | K <sub>x</sub> fall time  | (x = 1, 2), measured from<br>0.9 × V <sub>K30</sub> to 0.1 × V <sub>K30</sub><br>R <sub>Kx</sub> = 510Ω to K30,<br>C <sub>Kx</sub> = 470 pF to GNDB                       | K <sub>x</sub> | t <sub>Kfall</sub>   |      |      | 3    | μs   | A     |
| 16.28  | Propagation delay K <sub>x</sub> = low<br>to RxD <sub>x</sub> = low   | (x = 1, 2), measured from<br>K <sub>x</sub> = 0.4 × V <sub>K30</sub> to<br>RxD <sub>x</sub> = H to L  | K <sub>x</sub> | t <sub>PDKL</sub>    |      |      | 4    | μs   | A     |
| 16.29  | Propagation delay K <sub>x</sub> = high<br>to RxD <sub>x</sub> = high | (x = 1, 2), from<br>K <sub>x</sub> = 0.6 × V <sub>K30</sub> to<br>xD <sub>x</sub> = L to H  | K <sub>x</sub> | t <sub>PDkH</sub>    |      |      | 4    | μs   | A     |
| 16.30  | Symmetry of transmitter<br>delay                                      | (x = 1, 2),<br>t <sub>SYM_Tx</sub> = (t <sub>PDIL</sub> + t <sub>Kfall</sub> ) –<br>(t <sub>PDIH</sub> + t <sub>Krise</sub> )   | K <sub>x</sub> | t <sub>SYM_Tx</sub>  | –1   |      | 1    | μs   | A     |
| 16.31  | Symmetry of receiver<br>propagation delay                             | (x = 1, 2),<br>t <sub>SYM_Rx</sub> = t <sub>PDKL</sub> – t <sub>PDkH</sub>  | K <sub>x</sub> | t <sub>SYM_Rx</sub>  | –1   |      | 1    | μs   | A     |
| <b>LIN Bus Mode (Necessary for Operation: V<sub>K30</sub> = 8V to 18V)</b> |   |   |                |                      |      |      |      |      |       |
| 16.32  | Slew rate for rising and<br>falling edge                              | Measured between<br>high level = 0.8 × V <sub>K30</sub> and<br>low level = 0.2 × V <sub>K30</sub> ,<br>R <sub>K1</sub> = 1 kΩ to K30,<br>C <sub>K1</sub> = 3.3 nF to GNDB | K <sub>1</sub> | dV <sub>K1</sub> /dt | 1    |      | 3    | V/μs | A     |
| 16.33  | Maximum baud rate   |   | K <sub>1</sub> | t <sub>Kx</sub>      | 20   |      |      | kBd  | A     |
| 16.34  | Propagation delay TxD <sub>1</sub> low<br>to K <sub>1</sub> = low     | Measured from TxD <sub>1</sub><br>H-> L to K <sub>1</sub> = 0.9 × V <sub>K30</sub><br>R <sub>K1</sub> = 1 kΩ to K30,<br>C <sub>K1</sub> = 3.3 nF to GNDB                  | K <sub>1</sub> | t <sub>PDIL</sub>    |      |      | 2.5  | μs   | A     |
| 16.35  | Propagation delay TxD <sub>1</sub> high<br>to K <sub>1</sub> = high   | Measured from TxD <sub>1</sub><br>L to H to K <sub>1</sub> = 0.1 × V <sub>K30</sub><br>R <sub>K1</sub> = 1 kΩ to K30,<br>C <sub>K1</sub> = 3.3 nF to GNDB                 | K <sub>1</sub> | t <sub>PDIH</sub>    |      |      | 2.5  | μs   | A     |
| 16.36  | Propagation delay K <sub>1</sub> low to<br>RxD <sub>1</sub> = low     | Measured from<br>K <sub>1</sub> = 0.4 × V <sub>K30</sub> to<br>RxD <sub>1</sub> = H to L  | K <sub>1</sub> | t <sub>PDKL</sub>    |      |      | 4    | μs   | A     |

\*) Type means: A = 100% tested, B = 100% correlation tested, C = Characterized on samples, D = Design parameter

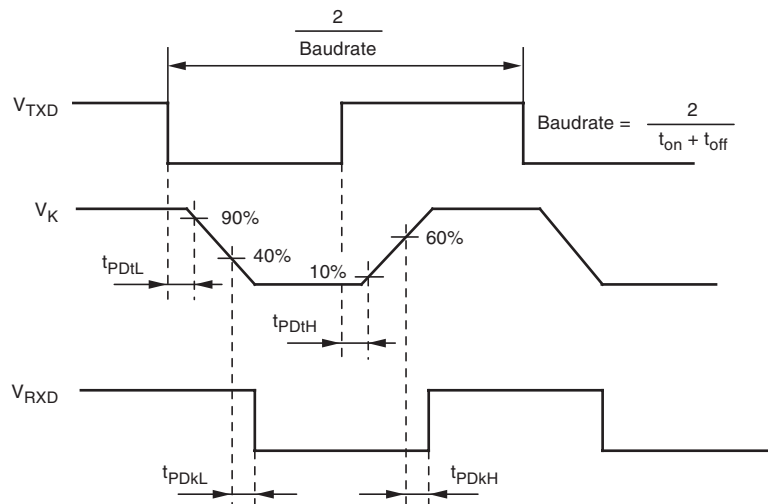

**Table 17-1.** Electrical Characteristics (Continued)– LIN/ISO 9141 Interfaces

| No.                   | Parameters  | Test Conditions  | Pin   | Symbol        | Min               | Typ. | Max.                 | Unit  | Type*       |
|-----------------------|---|--|-------|---------------|-------------------|------|----------------------|---|-------------|
| 16.37                 | Propagation delay $K_1$ high to $RxD_1 = \text{high}$ | Measured from $K_1 = 0.6 \times V_{K30}$ to $RxD_1 = L$ to $H$   | $K_1$ | $t_{PDKH}$    |                   |      | 4                    | $\mu\text{s}$                                   | A           |
| 16.38                 | Symmetry of transmitter delay                         | $t_{SYM\_T1} = t_{PDIL} - t_{PDIH}$  | $K_1$ | $t_{SYM\_T1}$ | -1                |      | 1                    | $\mu\text{s}$                                   | A           |
| 16.39                 | Symmetry of receiver propagation delay                | $t_{SYM\_R1} = t_{PDKL} - t_{PDKH}$  | $K_1$ | $t_{SYM\_R1}$ | -1                |      | 1                    | $\mu\text{s}$                                   | A           |
| <b>LS Driver Mode</b> |   |  |       |               |                   |      |                      |   |             |
| 16.40                 | $K_x$ output voltage drop                             | $I_{Kx} = 40 \text{ mA}$<br>$I_{Kx} = 20 \text{ mA}$   | $K_x$ | $V_{Kx}$      |                   |      | 1.7<br>1.2           | V   | A           |
| 16.41                 | $K_x$ switch-on delay                                 | ( $x = 1, 2$ ), measured from rising edge of SSQ to $V_{Kx} = 16.40\text{V}$ , $R_{Kx} = 250\Omega$ to $K30$ , $C_{Kx} = 3.3 \text{ nF}$ to $GNDB$   | $K_x$ | $t_{Kx}$      |                   |      | 50                   | $\mu\text{s}$                                   | A           |
| 16.42                 | $K_x$ switch-off delay                                | ( $x = 1, 2$ ), measured from rising edge of SSQ to $V_{Kx} = 0.9 \times V_{K30}$ , $R_{Kx} = 250\Omega$ to $K30$ , $C_{Kx} = 3.3 \text{ nF}$ to $GNDB$  | $K_x$ | $t_{Kx}$      |                   |      | 10                   | $\mu\text{s}$                                   | A           |
| 16.43                 | $K_x$ leakage current                                 | ( $x = 1, 2$ ), output driver deactivated, AMUX measurement activated and deactivated<br>$K30 = 5.5\text{V}$ to $15\text{V}$<br>$K30 > 15\text{V}$ to $25\text{V}$<br>$K30 > 25\text{V}$ to $40\text{V}$ | $K_x$ | $I_{Kx}$      | -10<br>-10<br>-10 |      | +100<br>+160<br>+260 | $\mu\text{A}$<br>$\mu\text{A}$<br>$\mu\text{A}$ | A<br>A<br>A |
| 16.44                 | $K_x$ leakage current                                 | ( $x = 1, 2$ ), output driver deactivated, AMUX measurement deactivated<br>$K30 = 5.5\text{V}$ to $40\text{V}$<br>$K_x = -25\text{V}$  | $K_x$ | $I_{Kx}$      | -150              |      | +10                  | $\mu\text{A}$                                   | A           |

\*) Type means: A = 100% tested, B = 100% correlation tested, C = Characterized on samples, D = Design parameter

**Figure 17-2.** Timing LIN/ISO 9141 Interface



## 18. Voltage/Current Sources (IASG<sub>x</sub> Sources)

For a variable resistance measurement and especially for buckle-switch detection, five constant voltage sources, switchable between two different voltages (V1 and V2) are implemented. The current delivered by these voltage sources is mirrored by a factor of 1 / 10 or 1 / 15 to the pin ISENS and causes a voltage drop at the external resistor connected to this pin. This voltage drop can be measured at pin UZP by choosing the corresponding AMUX command. The external resistor at pin IASG<sub>x</sub> can be calculated using the following formulas:

$$R_{IASGx} = \frac{R_{ISENS}}{10} \times \frac{V_{V1} - V_{V2}}{V_{ISENS1} - V_{ISENS2}} \text{ or}$$

$$R_{IASGx} = \frac{R_{ISENS}}{15} \times \frac{V_{V1} - V_{V2}}{V_{ISENS1} - V_{ISENS2}}$$

The current through pin IASG<sub>x</sub> is internally limited to a value between  $I_{IASGx} = -150$  mA and  $-50$  mA. If the voltage at pin ISENS becomes higher than  $V_{VPERI}$ , the voltage at pin IASG and, consequently, the current at pin IASG<sub>x</sub> is reduced until  $V_{ISENS} = V_{VPERI}$ . This function can be used to reduce the current limitation of pin IASG<sub>x</sub> to values lower than the internal limit by choosing an adequate external resistor at pin ISENS. In this case, the maximum current through pin IASG<sub>x</sub> can be calculated as:

$$I_{IASGxlim} = 10 \times \frac{V_{VPERI}}{R_{ISENS}} \text{ or}$$

$$I_{IASGxlim} = 15 \times \frac{V_{VPERI}}{R_{ISENS}}$$

For high accuracy, the IASG<sub>x</sub> current needs to be between 0.5 mA and 40 mA, and the maximum ISENS voltage must be  $< V_{VPERI} - 40\%$ . Under a clamping condition, the voltage at pin ISENS is clamped to  $V_{VPERI} + 5\%$ . Calculation of the resistor at pin ISENS:

$$R_{SENS} = 0.96 \times V_{VPERI} \times \frac{CR1}{I_{ASGmax}}$$

In applications with one or more unused IASG channels, the IASG pins can be used as measurement inputs. The five IASG pins are connected to the analog multiplexer block via different dividers. Voltages applied to these IASG pins can be measured at the UZP pin, selected via SPI commands.

Figure 18-1. Functional Principle of the IASG Interface

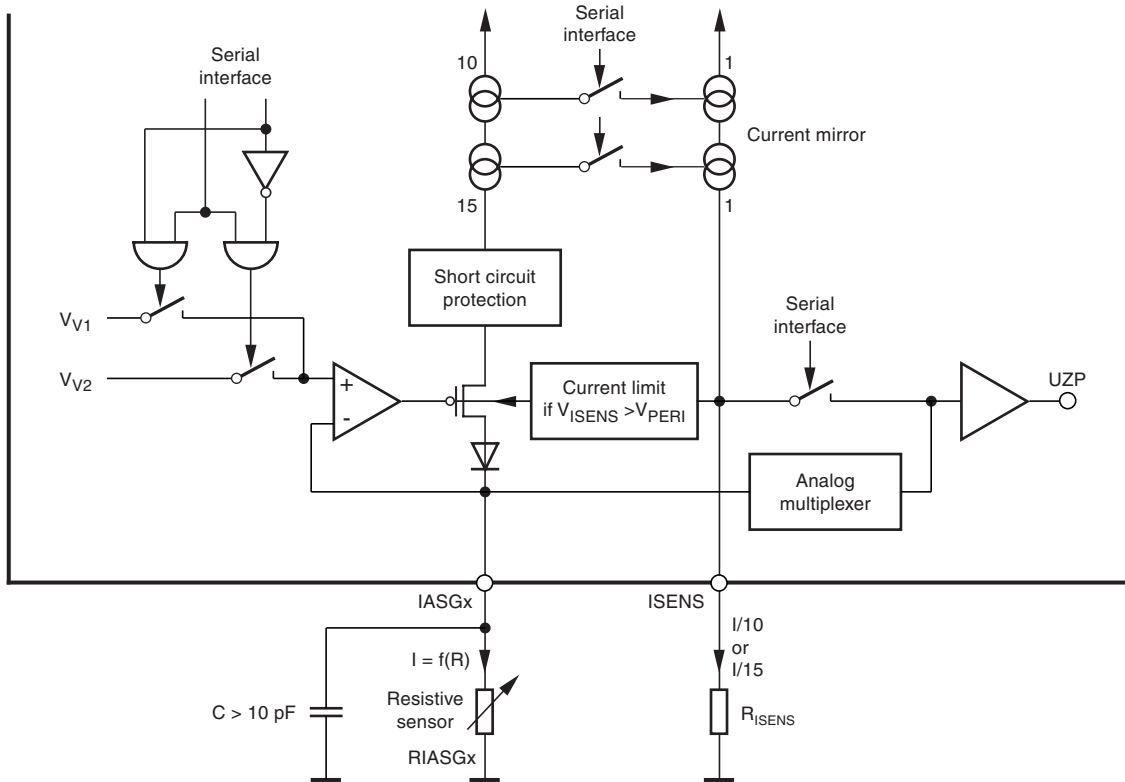

Necessary for operation:

$V_{V_{CORE}}$  and  $V_{V_{PERI}} >$  Reset threshold,  $V_{EVZ} = 9V$  to  $40V$  for operation with IASGx switched to 5V

$V_{V_{CORE}}$  and  $V_{V_{PERI}} >$  Reset threshold,  $V_{EVZ} = 15V$  to  $40V$  for operation with IASGx switched to 10V

$V_{INT} = 3.7V$  to  $5.47V$ ,  $V_{CP} > V_{EVZ} + 7V$

Operating conditions of all other supply pins:

$V_{K30}$  and  $V_{VSAT}$  are within functional range limits,  $T_j = -40^{\circ}C$  to  $150^{\circ}C$

Other pins:

As defined in [Section 4. "Functional Range" on page 8](#),  $C_{IASGx} \geq 10$  nF and  $825\Omega \geq R_{ISENS} \geq 5$  k $\Omega$

**Table 18-1. Electrical Characteristics – Voltage/Current Sources (IASG<sub>x</sub> Sources)**

| No.   | Parameters  | Test Conditions  | Pin               | Symbol                         | Min  | Typ. | Max.        | Unit   | Type*  |
|-------|---|--|-------------------|--------------------------------|------|------|-------------|--------|--------|
| 17.1  | Output voltage (V1)   | (x = 1 to 5),<br>-40 mA < I <sub>IASGx</sub> < -0.5 mA<br>V <sub>I<sub>SENS</sub></sub> = 0.96 × V <sub>V<sub>PERI</sub></sub>   | IASG <sub>x</sub> | V1 <sub>IASGx</sub>            | -6%  | 10   | +6%         | V      | A      |
| 17.2  | Output voltage (V2)   | (x = 1 to 5),<br>-40 mA < I <sub>IASGx</sub> < -0.5 mA<br>V <sub>I<sub>SENS</sub></sub> = 0.96 × V <sub>V<sub>PERI</sub></sub><br>IASG <sub>x</sub> switched to 5V<br>V <sub>EVZ</sub> > 11V                 | IASG <sub>x</sub> | V2 <sub>IASGx</sub>            | -6%  | 5    | +6%         | V      | A      |
| 17.2a | Output voltage (V2)   | (x = 1 to 5),<br>-25 mA < I <sub>IASGx</sub> < -0.5 mA<br>V <sub>I<sub>SENS</sub></sub> = 0.96 × V <sub>V<sub>PERI</sub></sub><br>IASG <sub>x</sub> switched to 5V<br>V <sub>EVZ</sub> > 9V to 11V           | IASG <sub>x</sub> | V2 <sub>IASGx</sub>            | -6%  | 5    | +6%         | V      | A      |
| 17.3  | Output voltage overshoot at IASGx due to regulator characteristic | (x = 1 to 5)<br>when IASG = 5V<br>when IASG = 10V  | IASG <sub>x</sub> | ΔV <sub>IASGx</sub>            |      |      | 5.9<br>11.3 | V<br>V | A<br>A |
| 17.4  | Maximum duration of voltage overshoot at IASGx                    | (x = 1 to 5),<br>with V <sub>IASGx</sub> = 10V / 0.5 mA <<br>R <sub>LOAD</sub> < V <sub>IASGx</sub> = 5V / 40 mA   | IASG <sub>x</sub> | t <sub>IASGx</sub>             |      |      | 30          | μs     | A      |
| 17.5  | Linear range for current mirror at IASGx                          | (x = 1 to 5),<br>0V = V <sub>I<sub>SENS</sub></sub> = 0.96 × V <sub>V<sub>PERI</sub></sub>   | IASG <sub>x</sub> | I <sub>IASGx</sub>             | -40  |      | -0.5        | mA     | A      |
| 17.6  | Internal current limitation at IASG <sub>x</sub>                  | (x = 1 to 5)   | IASG <sub>x</sub> | I <sub>IASGx</sub>             | -150 |      | -50         | mA     | A      |
| 17.7  | Current ratio #1  | (x = 1 to 5),<br>CR <sub>1x</sub> = I <sub>IASGx</sub> / I <sub>I<sub>SENS</sub></sub><br>0V = V <sub>I<sub>SENS</sub></sub> = 0.96 × V <sub>V<sub>PERI</sub></sub><br>-40 mA < I <sub>IASGx</sub> < -0.5mA  | IASG <sub>x</sub> | CR <sub>1x</sub>               | -3%  | 9.9  | +3%         |        | A      |
| 17.8  | Current ratio #2  | (x = 1 to 5),<br>CR <sub>2x</sub> = I <sub>IASGx</sub> / I <sub>I<sub>SENS</sub></sub><br>0V = V <sub>I<sub>SENS</sub></sub> = 0.96 × V <sub>V<sub>PERI</sub></sub><br>-40 mA < I <sub>IASGx</sub> < -0.5 mA | IASG <sub>x</sub> | CR <sub>2x</sub>               | -3%  | 14.9 | +3%         |        | A      |
| 17.9  | Settling time   | (x = 1 to 5),<br>R <sub>IASGx</sub> = 250Ω, no capacitive load at IASGx  | ISENSE            | t <sub>I<sub>SENSE</sub></sub> | 0    |      | 50          | μs     | A      |
| 17.10 | Switch-on delay   | (x = 1 to 5)<br>Measured from rising edge of SSQ to<br>V <sub>IASGx</sub> = 0.1 × V <sub>IASGx</sub><br>R <sub>IASGx</sub> = 250Ω, no capacitive load at IASGx   | IASG <sub>x</sub> | t <sub>IASGx</sub>             | 0    |      | 50          | μs     | A      |

\*) Type means: A = 100% tested, B = 100% correlation tested, C = Characterized on samples, D = Design parameter

**Table 18-1.** Electrical Characteristics (Continued)– Voltage/Current Sources (IASG<sub>x</sub> Sources)

| No.   | Parameters  | Test Conditions  | Pin               | Symbol       | Min                     | Typ. | Max.                    | Unit    | Type* |
|-------|---|--|-------------------|--------------|-------------------------|------|-------------------------|---------|-------|
| 17.11 | Output voltage clamping<br>( $V_{ISENS} \leq V_{VPERI}$ ) | $I_{IASGx} > CR_Y \times V_{VPERI} / R_{ISENS}$<br>( $x = 1$ to 5), ( $Y = 1, 2$ )<br>( $V_{ISENS} \leq V_{VPERI}$ regulator active) | ISENSE            | $V_{ISENSE}$ | $0.96 \times V_{VPERI}$ |      | $1.05 \times V_{VPERI}$ | V       | A     |
| 17.12 | ISENS leakage current                                     | $V_{ISENS} = 0V$ to $0.96 \times V_{VPERI}$  | ISENSE            | $I_{ISENSE}$ | -1.6                    |      | +1.6                    | $\mu A$ | A     |
| 17.13 | IASG <sub>x</sub> leakage current                         | ( $x = 1$ to 5)<br>IASG <sub>x</sub> channel deactivated,<br>$0V < V_{IASGx} < V_{EVZ}$  | IASG <sub>x</sub> | $I_{IASGx}$  | -1.6                    |      | +1.6                    | $\mu A$ | A     |

\*) Type means: A = 100% tested, B = 100% correlation tested, C = Characterized on samples, D = Design parameter

## 19. AMUX (Analog Multiplexer for Voltage Measurements)

Various voltages and the chip temperature inside of the ATA6264 can be measured at the analog measurement output UZP. Different voltage dividers ensure that the values of the measured voltages at UZP are in the range of 0V to  $V_{PERI}$ . To select a specific measurement, a serial interface command has to be sent to the ATA6264.

For the list of measurable voltages and temperatures, refer to [Section 22. "Serial Interface Commands" on page 68](#). The overall accuracy of the measurement part inside the ATA6264 can be calculated using the following formula:

$$V_{UZP} = \left[ \frac{V_{meas}}{\text{ratio} \pm \text{ratio tolerance}} \right] \pm V_{UZPoffset}$$

**Figure 19-1.** AMUX Tolerances

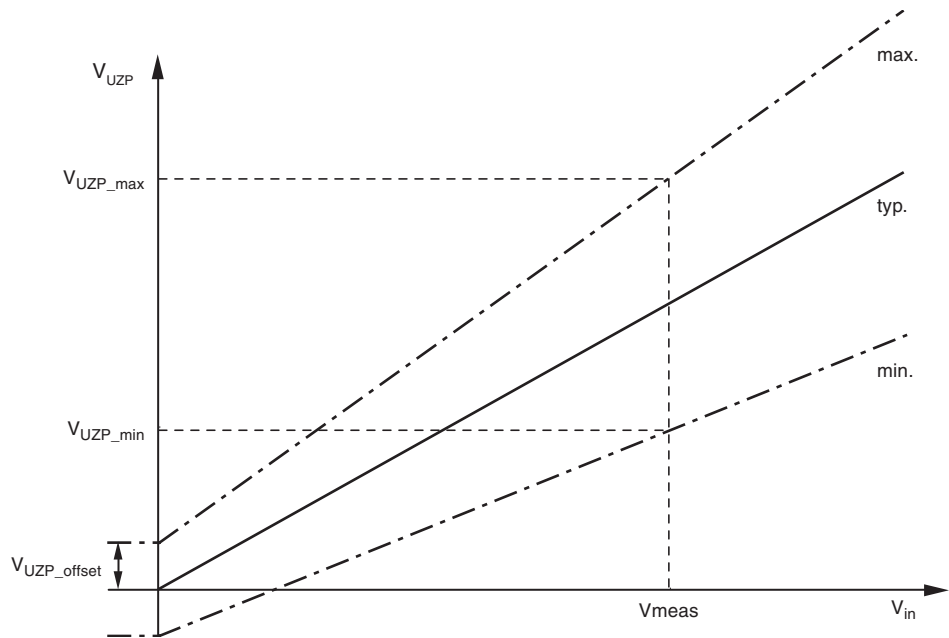

In order to describe the behavior of the whole measurement properly, the tolerance of the voltage-divider ratio (ratio tolerance) and the offset tolerance of the UZP buffer ( $V_{UZPoffset}$ ) are defined in separate points. The UZP buffer is defined in the following section.

Necessary for operation:

$$V_{EVZ} = 8V \text{ to } 40V \text{ or } V_{CP} = 10V \text{ to } 50V, V_{VINT} = 3.7V \text{ to } 5.47V$$

Operating conditions of all other supply pins:

$$V_{K30}, V_{VSAT}, V_{VPERI} \text{ and } V_{VCORE} \text{ are within functional range limits, } T_j = -40^{\circ}\text{C to } +150^{\circ}\text{C}$$

Other pins:

As defined in [Section 4. "Functional Range" on page 8](#).

Table 19-1. Electrical Characteristics – AMUX (Analog Multiplexer for Voltage Measurements)

| No.    | Parameters                  | Test Conditions   | Pin | Symbol          | Min | Typ.                                 | Max. | Unit | Type*  |
|--------|-----------------------------|---|-----|-----------------|-----|--------------------------------------|------|------|--------|
| 18.1   | Output offset error         | Has to be calculated from the values of the differential measurement        | UZP | $V_{UZPoffset}$ | -5  |                                      | +15  | mV   | A      |
| 18.2   | Ratio $V_{K15} / V_{UZP}$   | For $V_{VPERI} = 5V$ (1.5V to 3V)<br>For $V_{VPERI} = 5V$ (> 3V to 25V)     | UZP | Ratio           |     | $6.05 \pm 4\%$<br>$6.05 \pm 2.3\%$   |      |      | A<br>A |
| 18.2a  | Ratio $V_{K15} / V_{UZP}$   | For $V_{VPERI} = 3.3V$ (1.5V to 3V)<br>For $V_{VPERI} = 3.3V$ (> 3V to 25V) | UZP | Ratio           |     | $9.12 \pm 6\%$<br>$9.12 \pm 2.3\%$   |      |      | A<br>A |
| 18.3   | Ratio $V_{K30} / V_{UZP}$   | For $V_{VPERI} = 5V$ (1.5V to 3V)<br>For $V_{VPERI} = 5V$ (> 3V to 25V)     | UZP | Ratio           |     | $6.04 \pm 6\%$<br>$6.04 \pm 2.3\%$   |      |      | A<br>A |
| 18.3a  | Ratio $V_{K30} / V_{UZP}$   | For $V_{VPERI} = 3.3V$ (1.5V to 3V)<br>For $V_{VPERI} = 3.3V$ (> 3V to 25V) | UZP | Ratio           |     | $9.11 \pm 6\%$<br>$9.11 \pm 2.3\%$   |      |      | A<br>A |
| 18.4   | Ratio $V_{EVZ} / V_{UZP}$   | For $V_{VPERI} = 5V$  | UZP | Ratio           |     | $9.9 \pm 2.3\%$                      |      |      | A      |
| 18.4a  | Ratio $V_{EVZ} / V_{UZP}$   | For $V_{VPERI} = 3.3V$  | UZP | Ratio           |     | $14.78 \pm 2.6\%$                    |      |      | A      |
| 18.5   | Ratio $V_{SAT} / V_{UZP}$   | For $V_{VPERI} = 5V$ (1.5V to 3V)<br>For $V_{VPERI} = 5V$ (> 3V to 25V)     | UZP | Ratio           |     | $6.05 \pm 6\%$<br>$6.05 \pm 2.3\%$   |      |      | A<br>A |
| 18.5a  | Ratio $V_{SAT} / V_{UZP}$   | For $V_{VPERI} = 3.3V$ (1.5V to 3V)<br>For $V_{VPERI} = 3.3V$ (> 3V to 25V) | UZP | Ratio           |     | $9.12 \pm 6\%$<br>$9.12 \pm 2.3\%$   |      |      | A<br>A |
| 18.6   | Ratio $V_{VCORE} / V_{UZP}$ | For $V_{VPERI} = V_{VCORE} = 5V$  | UZP | Ratio           |     | $2 \pm 2.3\%$                        |      |      | A      |
| 18.6a  | Ratio $V_{VCORE} / V_{UZP}$ | For $V_{VPERI} > V_{VCORE}$   | UZP | Ratio           |     | $0.995 \pm 1\%$                      |      |      | A      |
| 18.7   | Ratio $V_{ISENS} / V_{UZP}$ | $V_{VPERI} - 0.2V \geq V_{ISENS} \geq 0.2V$                                 | UZP | Ratio           |     | $0.992 \pm 1\%$                      |      |      | A      |
| 18.8   | Ratio $V_{K1} / V_{UZP}$    | For $V_{VPERI} = 5V$ (1.5V to 3V)<br>For $V_{VPERI} = 5V$ (> 3V to 25V)     | UZP | Ratio           |     | $6.06 \pm 3.5\%$<br>$6.06 \pm 2.3\%$ |      |      | A<br>A |
| 18.8a  | Ratio $V_{K1} / V_{UZP}$    | For $V_{VPERI} = 3.3V$ (1.5V to 3V)<br>For $V_{VPERI} = 3.3V$ (> 3V to 25V) | UZP | Ratio           |     | $9.16 \pm 3.5\%$<br>$9.16 \pm 2.3\%$ |      |      | A<br>A |
| 18.9   | Ratio $V_{K2} / V_{UZP}$    | For $V_{VPERI} = 5V$ (1.5V to 3V)<br>For $V_{VPERI} = 5V$ (> 3V to 25V)     | UZP | Ratio           |     | $6.06 \pm 3.5\%$<br>$6.06 \pm 2.3\%$ |      |      | A<br>A |
| 18.9a  | Ratio $V_{K2} / V_{UZP}$    | For $V_{VPERI} = 3.3V$ (1.5V to 3V)<br>For $V_{VPERI} = 3.3V$ (> 3V to 25V) | UZP | Ratio           |     | $9.16 \pm 3.5\%$<br>$9.16 \pm 2.3\%$ |      |      | A<br>A |
| 18.10  | Ratio $V_{IASG1} / V_{UZP}$ | For $V_{VPERI} = 5V$  | UZP | Ratio           |     | $10 \pm 3\%$                         |      |      | A      |
| 18.10a | Ratio $V_{IASG1} / V_{UZP}$ | For $V_{VPERI} = 3.3V$  | UZP | Ratio           |     | $14.75 \pm 3\%$                      |      |      | A      |
| 18.11  | Ratio $V_{IASG2} / V_{UZP}$ | For $V_{VPERI} = 5V$ (1.5V to 3V)<br>For $V_{VPERI} = 5V$ (> 3V to 25V)     | UZP | Ratio           |     | $6.04 \pm 6\%$<br>$6.04 \pm 2.3\%$   |      |      | A<br>A |
| 18.11a | Ratio $V_{IASG2} / V_{UZP}$ | For $V_{VPERI} = 3.3V$ (1.5V to 3V)<br>For $V_{VPERI} = 3.3V$ (> 3V to 25V) | UZP | Ratio           |     | $9.11 \pm 6\%$<br>$9.11 \pm 2.3\%$   |      |      | A<br>A |
| 18.12  | Ratio $V_{IASG3} / V_{UZP}$ | For $V_{VPERI} = 5V$ (1.5V to 3V)<br>For $V_{VPERI} = 5V$ (> 3V to 25V)     | UZP | Ratio           |     | $6.04 \pm 6\%$<br>$6.04 \pm 2.3\%$   |      |      | A<br>A |
| 18.12a | Ratio $V_{IASG3} / V_{UZP}$ | For $V_{VPERI} = 3.3V$ (1.5V to 3V)<br>For $V_{VPERI} = 3.3V$ (> 3V to 25V) | UZP | Ratio           |     | $9.11 \pm 6\%$<br>$9.11 \pm 2.3\%$   |      |      | A<br>A |
| 18.13  | Ratio $V_{IASG4} / V_{UZP}$ | For $V_{VPERI} = 5V$ (1.5V to 3V)<br>For $V_{VPERI} = 5V$ (> 3V to 25V)     | UZP | Ratio           |     | $6.04 \pm 6\%$<br>$6.04 \pm 2.3\%$   |      |      | A<br>A |
| 18.13a | Ratio $V_{IASG4} / V_{UZP}$ | For $V_{VPERI} = 3.3V$ (1.5V to 3V)<br>For $V_{VPERI} = 3.3V$ (> 3V to 25V) | UZP | Ratio           |     | $9.11 \pm 6\%$<br>$9.11 \pm 2.3\%$   |      |      | A<br>A |
| 18.14  | Ratio $V_{IASG5} / V_{UZP}$ |   | UZP | Ratio           |     | $0.995 \pm 1\%$                      |      |      | A      |

\*) Type means: A = 100% tested, B = 100% correlation tested, C = Characterized on samples, D = Design parameter

**Table 19-1. Electrical Characteristics (Continued)– AMUX (Analog Multiplexer for Voltage Measurements)**

| No.   | Parameters  | Test Conditions   | Pin | Symbol      | Min                              | Typ. | Max.              | Unit | Type*  |
|---|---|---|-----|-------------|----------------------------------|------|-------------------|------|--------|
| 18.15   | Ratio $V_{USP} / V_{UZP}$   | For $V_{VPERI} = 5V$ (1.5V to 3V)<br>For $V_{VPERI} = 5V$ (> 3V to 25V)     | UZP | Ratio       | 6.02 ± 6%<br>6.02 ± 2.3%         |      |                   |      | A<br>A |
| 18.15a  | Ratio $V_{USP} / V_{UZP}$   | For $V_{VPERI} = 3.3V$ (1.5V to 3V)<br>For $V_{VPERI} = 3.3V$ (> 3V to 25V) | UZP | Ratio       | 9.07 ± 6%<br>9.07 ± 2.3%         |      |                   |      | A<br>A |
| <b>Special Measurement (For Detection of Band-gap Defect)</b> |   |   |     |             |                                  |      |                   |      |        |
| 18.16   | Ratio $V_{VINT} / V_{UZP}$  |   | UZP | Ratio       | 3.99 ± 2.6%                      |      |                   |      | A      |
| 18.17   | Voltage $0.9 \times V_{VPERI}$<br>switched to $V_{UZP}$             |   | UZP | Ratio       | $(0.9 \times V_{VPERI}) \pm 2\%$ |      |                   |      | A      |
| 18.18   | Voltage $0.1 \times V_{VPERI}$<br>switched to $V_{UZP}$             |   | UZP | Ratio       | $(0.1 \times V_{VPERI}) \pm 2\%$ |      |                   |      | A      |
| 18.19   | Input voltage range for<br>proper function of 10 or 14.6<br>divider |   |     | $V_{Input}$ | 6                                |      | 40                | V    | A      |
| 18.20   | Input voltage range for<br>proper function of 6 or 9.1<br>divider   |   |     | $V_{Input}$ | 1.5                              |      | 25                | V    | A      |
| 18.21   | Input voltage range for<br>proper function of 4 and 2<br>divider    |   |     | $V_{Input}$ | 4                                |      | 6                 | V    | A      |
| 18.22   | Input voltage range for<br>proper function of 1 buffer              |   |     | $V_{Input}$ | 0.2                              |      | $V_{VPERI} - 0.2$ | V    | A      |
| 18.23   | Ratio $V_{REF} / V_{UZP}$   |   |     |             | -2%                              | 1    | 0%                |      | A      |

\*) Type means: A = 100% tested, B = 100% correlation tested, C = Characterized on samples, D = Design parameter



## 20. UZP Buffer

The pin UZP is an analog output pin of the ATA6264. The UZP buffer is realized as a tristate output with the ability to drive to  $V_{PERI}$  as well as to  $G_NDA$ . The selected measurement result is given to the pin UZP as long as no new measurement is selected or the tristate command has been sent. Driver capability is typically 4 mA.

**Figure 20-1.** Functional Principle of the UZP Buffer

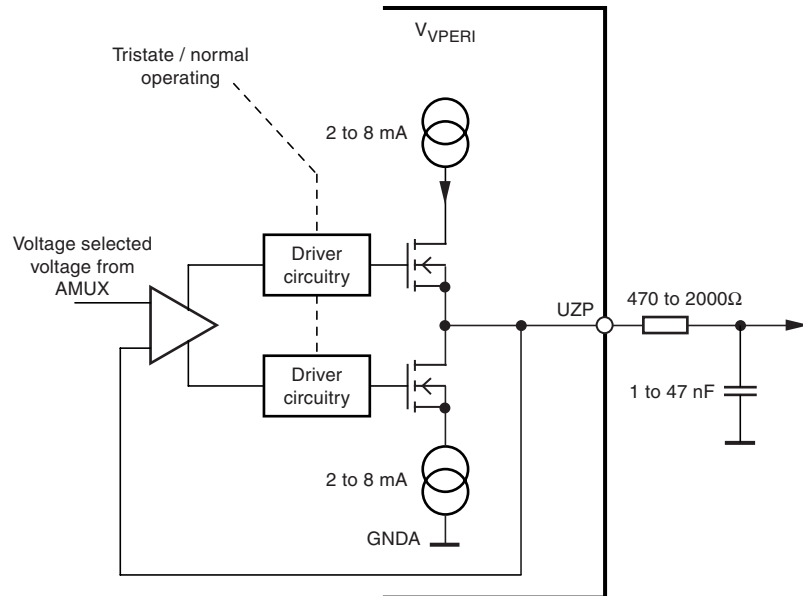

Necessary for operation:

$V_{PERI} >$  Reset threshold,  $V_{CP} = 10V$  to  $50V$ ,  $V_{VINT} = 3.7V$  to  $5.47V$

Operating conditions of all other supply pins:

$V_{K30}$ ,  $V_{EVZ}$ ,  $V_{VSAT}$  and  $V_{VCORE}$  are within functional range limits,  $T_J = -40^{\circ}C$  to  $+150^{\circ}C$

Other pins:

As defined in [Section 4. "Functional Range" on page 8.](#)

**Table 20-1. Electrical Characteristics – UZP Buffer**

| No.   | Parameters   | Test Conditions  | Pin | Symbol    | Min                  | Typ. | Max.                 | Unit     | Type* |
|-------|--|--|-----|-----------|----------------------|------|----------------------|----------|-------|
| 19.1  | Output current high side, driving current with measurement activated | $V_{UZP} = 0V$ ,<br>UZP connected to GND   | UZP | $I_{UZP}$ | -8                   |      | -2                   | mA       | A     |
| 19.2  | Output current low side, sink current with measurement activated     | $V_{UZP} = V_{VPERI}$<br>UZP connected to GND  | UZP | $I_{UZP}$ | 2                    |      | 8                    | mA       | A     |
| 19.3  | Output settling time   | Measured from rising edge of SSQ to 90% of $V_{UZP}$ , no load at pin UZP  | UZP | $t_{UZP}$ |                      |      | 10                   | $\mu s$  | A     |
| 19.4  | Output settling time   | Load 2 k $\Omega$ /22 nF low-pass filter connected to pin UZP, measured from rising edge of SSQ to 90% of $V_{Low\ pass\ filter\ out}$ | UZP | $t_{UZP}$ |                      |      | 250                  | $\mu s$  | A     |
| 19.5  | Output resistance  |  | UZP | $R_{UZP}$ |                      |      | 100                  | $\Omega$ | A     |
| 19.6  | Linear measurement range   |  | UZP | $V_{UZP}$ | 0.2                  |      | $V_{VPERI} - 0.2$    | V        | A     |
| 19.7  | Maximum output voltage   | $V_{IASG5}$ switched via AMUX to UZP, $V_{IASG5} = 6V$   | UZP | $V_{UZP}$ | $V_{VPERI} - 50\ mV$ |      | $V_{VPERI} + 50\ mV$ | V        | A     |
| 19.8  | Output leakage current   | $V_{UZP} = 0V$ to $V_{VPERI}$ , UZP buffer in tristate mode  | UZP | $I_{UZP}$ | -5                   |      | +5                   | $\mu A$  | A     |
| 19.9  | Output capacitance   | UZP buffer in tristate mode  | UZP | $C_{UZP}$ | 0                    |      | 10                   | pF       | D     |
| 19.10 | Time to switch to tristate mode                                      | Measured from rising edge of SSQ to $I_{leak}$ within tolerance  | UZP | $t_{UZP}$ |                      |      | 3                    | $\mu s$  | A     |

\*) Type means: A = 100% tested, B = 100% correlation tested, C = Characterized on samples, D = Design parameter

## 21. Chip Temperature Measurement

A serial interface command allows measuring a chip-temperature-dependent voltage which is generated by two diodes connected in series. Three 2-diode sensors are connected in parallel and located in the following blocks: VPERI, VCORE, and VSAT. The diodes are supplied by a temperature-constant current source, the voltage drop of the diodes is switched via AMUX to pin UZP. If the overtemperature level is exceeded, bit a7 in the status register is set to “1”.

Necessary for operation:

$$V_{INT} = 3.7V \text{ to } 5.47V$$

Operating conditions of all other supply pins:

$V_{K30}$ ,  $V_{EVZ}$ ,  $V_{VSAT}$ ,  $V_{VPERI}$  and  $V_{VCORE}$  are within functional range limits,  $T_j = -40^{\circ}C$  to  $150^{\circ}C$

Other pins:

As defined in [Section 4. "Functional Range" on page 8](#).

**Table 21-1.** Electrical Characteristics – Chip Temperature Measurement

| No.   | Parameters   | Test Conditions  | Pin | Symbol    | Min  | Typ. | Max. | Unit        | Type* |
|-------|--|--|-----|-----------|------|------|------|-------------|-------|
| 20.1  | Temperature coefficient of chip-temperature sensor | Chip temperature switched via AMUX to UZP                      | UZP | $V_{UZP}$ | -4   | -3.6 | -3.2 | mV/K        | D     |
| 20.2  | Output voltage temperature sensor                  | Chip temperature switched via AMUX to UZP, $T_j = 25^{\circ}C$ | UZP | $V_{UZP}$ | 1.29 |      | 1.54 | V           | A     |
| 20.3  | Threshold overtemperature detection                | If overtemperature is detected, voltage drops by 35 mV         | UZP | $V_{UZP}$ | 155  |      | 185  | $^{\circ}C$ | B     |
| 20.3a | Hysteresis for overtemperature detection           |  | UZP | $V_{UZP}$ | 5    |      | 25   | K           | B     |

\*) Type means: A = 100% tested, B = 100% correlation tested, C = Characterized on samples, D = Design parameter

## 22. Serial Interface Commands

### 22.1 Overview

All functions of the ATA6264 are triggered by 16-bit serial interface commands. Some of these commands are latched because their actions have to continue for a longer time. Other commands have to be executed as long as no other command is received via the serial interface.

The pin SSQ (low active) is used to select the ATA6264. If pin SSQ is inactive (high), the output pin MISO is disabled (tristate) and the signals at the pins SCLK and MOSI are ignored and do not affect the data in the serial interface register.

With the falling edge at pin SSQ, the ATA6264 response on the previous command is latched in the ATA6264 status register and, after a short delay time, the signal at pin MISO is valid. With the rising edge at pin SCLK, the data at pin MOSI is shifted into the serial interface input register and the next bit of the status register is shifted to pin MISO. A command received at pin MOSI is valid and will be executed if the number of rising edges at pin SCLK was exactly 16 during data transmission; otherwise, the received signal will be ignored.

The *slave select pin*, SSQ, allows the individual selection of different slave SPI devices. Slave devices that are not selected do not interfere with SPI bus activities. To ensure deactivation of the device in case of an open SSQ pin, an internal current source is implemented to drive the SSQ pin to high level (VPERI).

All commands, independent of their function, consist of 16 bits. The serial interface includes a 16-bit input shift register, 16-bit latches, and a decoder logic block for the generation of the SPI command signals.

To suppress data transfer errors in the case of spikes or glitches on the clock signal, a 16-clock-cycle counter is provided. Only after 16 clock cycles does the rising edge of SSQ cause an internal signal *latch enable*, which transfers the data from the shift register to the 16-bit latch. The data word is decoded to address the correct functional block.

**Table 22-1.** Electrical Characteristics – Serial Interface Commands

| No.   | Parameters                        | Test Conditions | Pin             | Symbol     | Min | Typ. | Max. | Unit | Type*            |
|-------|-----------------------------------|-----------------|-----------------|------------|-----|------|------|------|------------------|
| 21.1  | SSQ to SCLK rising-edge isolation |                 | SCLK            | $t_{iso}$  | 100 |      |      | ns   | A <sup>(3)</sup> |
| 21.2  | SSQ lag time                      |                 | SSQ             | $t_{lag}$  | 100 |      |      | ns   | A <sup>(3)</sup> |
| 21.3  | Fall time                         |                 | SSQ, SCLK, MOSI | $t_f$      |     |      | 20   | ns   | A <sup>(3)</sup> |
| 21.3a | Fall time                         | <sup>(2)</sup>  | MISO            | $t_f$      |     |      | 20   | ns   | A                |
| 21.4  | Rise time                         |                 | SSQ, SCLK, MOSI | $t_r$      |     |      | 20   | ns   | A <sup>(3)</sup> |
| 21.4a | Rise time                         | <sup>(2)</sup>  | MISO            | $t_r$      |     |      | 20   | ns   | A                |
| 21.5  | Data set-up time                  |                 | MOSI            | $t_{su}$   | 20  |      |      | ns   | A <sup>(3)</sup> |
| 21.6  | Data hold time                    |                 | MOSI            | $t_{hold}$ | 20  |      |      | ns   | A <sup>(3)</sup> |

\*) Type means: A = 100% tested, B = 100% correlation tested, C = Characterized on samples, D = Design parameter

- Note:
1. Voltage levels for serial interface timing measurements: High level =  $0.7 \times V_{VPERI}$ , low level =  $0.2 \times V_{VPERI}$
  2. Timing specified with a 100-pF external load at pin MISO
  3. System requirement

Table 22-1. Electrical Characteristics (Continued)– Serial Interface Commands

| No.   | Parameters  | Test Conditions                                    | Pin             | Symbol                 | Min                            | Typ. | Max.                          | Unit          | Type*            |
|-------|---|--|-----------------|------------------------|--------------------------------|------|-------------------------------|---------------|------------------|
| 21.7  | Time from SSQ falling edge to MISO MSB valid  | (2)  | MISO            | $t_{\text{MISOMSB}_V}$ | 0                              |      | 400                           | ns            | A                |
| 21.8  | Time from SCLK rising edge to MISO valid  | (2)  | MISO            | $t_{\text{MISOV}}$     | 0                              |      | 40                            | ns            | A                |
| 21.9  | Time from SSQ rising edge to MISO tristate condition  | (2)  | MISO            | $t_{\text{MISOhiZ}}$   | 0                              |      | 40                            | ns            | A                |
| 21.10 | No-data time between serial interface commands  |  |                 | $t_{\text{nodata}}$    | 1.5                            |      |                               | $\mu\text{s}$ | A <sup>(3)</sup> |
| 21.11 | Clock frequency   |  | CLK             | $f_{\text{SCLK}}$      | 0                              |      | 8                             | MHz           | A <sup>(3)</sup> |
| 21.12 | Pull-up current VPERI   |  | SSQ             | $R_{\text{pu\_SSQ}}$   | -95                            |      | -45                           | $\mu\text{A}$ | A                |
| 21.13 | Pull-up current VPERI   |  | SCLK            | $R_{\text{pu\_SCLK}}$  | -95                            |      | -45                           | $\mu\text{A}$ | A                |
| 21.14 | SCLK high/low time  |  | SCLK            | $t_{\text{CL}}$        | 40                             |      |                               | ns            | A <sup>(3)</sup> |
| 21.15 | Input voltage high level  |  | SSQ, SCLK, MOSI | $V_H$                  |                                |      | $0.5 \times V_{\text{VPERI}}$ |               | A                |
| 21.16 | Input voltage low level   |  | SSQ, SCLK, MOSI | $V_L$                  | $0.25 \times V_{\text{VPERI}}$ |      |                               |               | A                |
| 21.17 | Input voltage hysteresis  |  | SCLK            | $V_{\text{HYS}}$       | 50                             |      | 250                           | mV            | A                |
| 21.18 | Output voltage high level   | $I_{\text{MISO}} = -1 \text{ mA to } 0 \text{ mA}$ | MISO            | $V_H$                  | $V_{\text{VPERI}} - 0.8$       |      | $V_{\text{VPERI}}$            | V             | A                |
| 21.19 | Output voltage low level  | $I_{\text{MISO}} = 0 \text{ mA to } 1 \text{ mA}$  | MISO            | $V_L$                  | 0                              |      | 0.4                           | V             | A                |
| 21.20 | Output current high level driven to short circuit   | $V_{\text{VPERI}} = 5\text{V}$                     | MISO            | $I_{\text{MISO}}$      | -47                            |      | -10                           | mA            | A                |
| 21.21 | Output current low level sinking from VPERI level   | $V_{\text{VPERI}} = 5\text{V}$                     | MISO            | $I_{\text{MISO}}$      | 6                              |      | 45                            | mA            | A                |
| 21.22 | Input capacitance   |  | SSQ, SCLK, MOSI | $C_{\text{IN}}$        |                                |      | 10                            | pF            | D                |
| 21.23 | Output capacitance  | Switched-off condition                             | MISO            | $C_{\text{MISO}}$      |                                |      | 10                            | pF            | D                |
| 21.24 | Leakage current   | Switched-off condition                             | MISO            | $I_{\text{MISO}}$      | -10                            |      | +10                           | $\mu\text{A}$ | A                |
| 21.25 | Number of clock cycles to be detected between falling and rising edge of SSQ, to set error signal in status register to "0" |  |                 |                        | 16                             |      | 16                            |               | A                |

\*) Type means: A = 100% tested, B = 100% correlation tested, C = Characterized on samples, D = Design parameter

- Note:
1. Voltage levels for serial interface timing measurements: High level =  $0.7 \times V_{\text{VPERI}}$ , low level =  $0.2 \times V_{\text{VPERI}}$
  2. Timing specified with a 100-pF external load at pin MISO
  3. System requirement

**Figure 22-1.** Timing Serial Interface

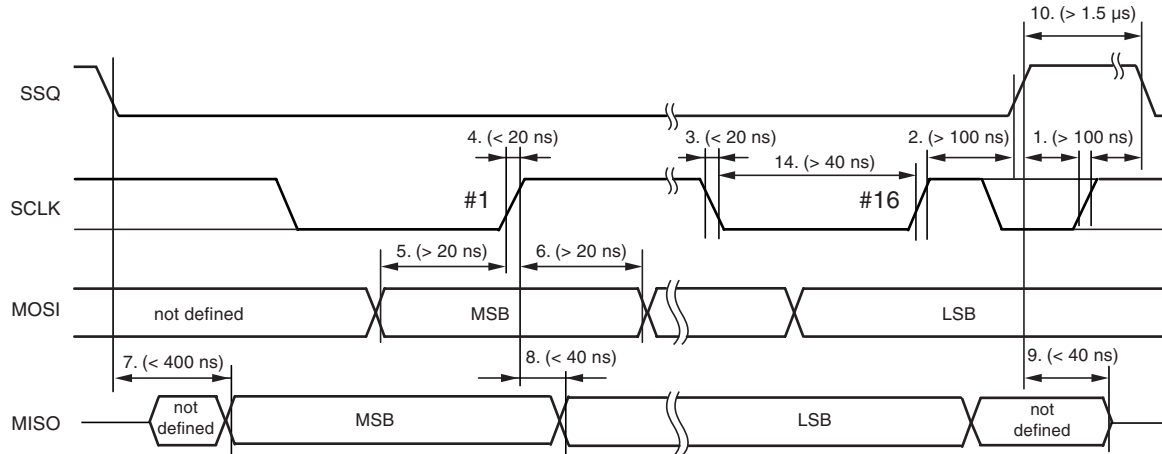

## 22.2 Set Commands

After a reset due to the watchdog or undervoltage, all internal control registers and decoded signals are set to their default values.

**Table 22-2.** Set of Serial Interface Commands

| Command             | Latch | Hex  | Description                               | MSByte  |   |   |   |   |   |   |   | LSByte          |   |   |   |   |   |   |   |
|---------------------|-------|------|---|---------|---|---|---|---|---|---|---|-----------------|---|---|---|---|---|---|---|
|                     |       |      |   | 7       | 6 | 5 | 4 | 3 | 2 | 1 | 0 | 7               | 6 | 5 | 4 | 3 | 2 | 1 | 0 |
|                     |       |      |   | Command |   |   |   |   |   |   |   | Option and Data |   |   |   |   |   |   |   |
| NOP                 | No    | 0000 |   | 0       | 0 | 0 | 0 | 0 | 0 | 0 | 0 | 0               | 0 | 0 | 0 | 0 | 0 | 0 |   |
| Key latch           | Yes   | 3xxx | See <a href="#">Table 22-3 on page 71</a> | 0       | 0 | 1 | 1 | x | x | x | x | x               | x | x | x | x | x | x |   |
| Watchdog            | No    | 6xxx | See <a href="#">Table 22-4 on page 71</a> | 0       | 1 | 1 | 0 | x | x | x | x | x               | x | x | x | x | x | x |   |
| Switch commands     | Yes   | 9xxx | See <a href="#">Table 22-5 on page 71</a> | 1       | 0 | 0 | 1 | x | x | x | x | x               | x | x | x | x | x | x |   |
| Initial programming | N/A   | Axxx | See <a href="#">Table 22-6 on page 72</a> | 1       | 0 | 1 | 0 | x | x | x | x | x               | x | x | x | x | x | x |   |
| Diagnosis           | No    | Cxxx | See <a href="#">Table 22-7 on page 72</a> | 1       | 1 | 0 | 0 | x | x | x | x | x               | x | x | x | x | x | x |   |
| IASG                | No    | Fxxx | See <a href="#">Table 22-8 on page 73</a> | 1       | 1 | 1 | 1 | x | x | x | x | x               | x | x | x | x | x | x |   |
| Test mode 1         | No    | 55AA |   | 0       | 1 | 0 | 1 | 0 | 1 | 0 | 1 | 1               | 0 | 1 | 0 | 1 | 0 | 1 |   |
| Test mode 2         | No    | AA55 |   | 1       | 0 | 1 | 0 | 1 | 0 | 1 | 0 | 0               | 1 | 0 | 1 | 0 | 1 | 0 |   |
| Test mode 3         | No    | 5500 |   | 0       | 1 | 0 | 1 | 0 | 1 | 0 | 1 | 0               | 0 | 0 | 0 | 0 | 0 | 0 |   |
| Test-mode enable    | No    | 5A5A |   | 0       | 1 | 0 | 1 | 1 | 0 | 1 | 0 | 0               | 1 | 0 | 1 | 1 | 0 | 1 |   |

Serial interface commands other than those listed in [Table 22-2 on page 70](#) lead to an interruption of measurements via AMUX, cause pin UZP to be switched to tristate, and IASG sources to be deactivated. The status of the latches does not change.

**Table 22-3.** Key Latch Commands

| Description               | MSByte |   |   |   |   |   |   |   | LSByte |   |   |   |   |   |   |   | Hex Code |
|---------------------------|--------|---|---|---|---|---|---|---|--------|---|---|---|---|---|---|---|----------|
|                           | 7      | 6 | 5 | 4 | 3 | 2 | 1 | 0 | 7      | 6 | 5 | 4 | 3 | 2 | 1 | 0 |          |
| Key latch set             | 0      | 0 | 1 | 1 | 1 | 1 | 1 | 1 | 1      | 1 | 1 | 1 | 1 | 1 | 1 | 1 | 3FFF     |
| Key latch reset (default) | 0      | 0 | 1 | 1 | 0 | 0 | 0 | 0 | 0      | 0 | 0 | 0 | 0 | 0 | 0 | 0 | 3000     |

**Table 22-4.** Watchdog Commands

| Description         | MSByte |   |   |   |   |   |   |   | LSByte |   |   |   |   |   |   |   | Hex Code |
|---------------------|--------|---|---|---|---|---|---|---|--------|---|---|---|---|---|---|---|----------|
|                     | 7      | 6 | 5 | 4 | 3 | 2 | 1 | 0 | 7      | 6 | 5 | 4 | 3 | 2 | 1 | 0 |          |
| Trigger watchdog    | 0      | 1 | 1 | 0 | 1 | 0 | 1 | 0 | 0      | 1 | 0 | 1 | 0 | 1 | 0 | 1 | 6A55     |
| Configure prescaler | 0      | 1 | 1 | 0 | 0 | 0 | 0 | 0 | 1      | 1 | 1 | 1 | 0 | a | b | c | 60Fx     |

**Table 22-5.** Switch Commands

| Description  | MSByte |   |   |   |   |   |   |   | LSByte |   |   |   |   |   |   |   | Hex Code |
|--|--------|---|---|---|---|---|---|---|--------|---|---|---|---|---|---|---|----------|
|  | 7      | 6 | 5 | 4 | 3 | 2 | 1 | 0 | 7      | 6 | 5 | 4 | 3 | 2 | 1 | 0 |          |
| Enable EVZ switching   | 1      | 0 | 0 | 1 | 1 | 0 | 1 | 0 | 0      | 1 | 0 | 1 | 1 | 0 | 1 | 0 | 9A5A     |
| EVZ switched to 33V  | 1      | 0 | 0 | 1 | 0 | 0 | 1 | 1 | 0      | 0 | 0 | 0 | 1 | 1 | 1 | 1 | 930F     |
| EVZ switched to 23V (default)  | 1      | 0 | 0 | 1 | 0 | 0 | 1 | 1 | 1      | 1 | 1 | 1 | 0 | 0 | 0 | 0 | 93F0     |
| EVZ switched to external divider   | 1      | 0 | 0 | 1 | 0 | 0 | 1 | 1 | 1      | 0 | 0 | 1 | 0 | 1 | 1 | 0 | 9396     |
| CP-OUT switched to high-ohmic state (default)  | 1      | 0 | 0 | 1 | 0 | 1 | 1 | 0 | 0      | 0 | 0 | 0 | 1 | 1 | 1 | 1 | 960F     |
| CP-OUT switched to low-impedance state   | 1      | 0 | 0 | 1 | 0 | 1 | 1 | 0 | 1      | 1 | 1 | 1 | 0 | 0 | 0 | 0 | 96F0     |
| K1 interface works as ISO9141 or LIN interface (depending on ISO/LIN bit of initial programming) (default) | 1      | 0 | 0 | 1 | 1 | 0 | 0 | 1 | 1      | 1 | 1 | 1 | 0 | 0 | 0 | 0 | 99F0     |
| K1 interface works in LS driver mode   | 1      | 0 | 0 | 1 | 1 | 0 | 0 | 1 | 1      | 1 | 1 | 1 | 1 | 1 | 1 | 1 | 99FF     |
| K1 switched to high-ohmic state (default)  | 1      | 0 | 0 | 1 | 1 | 1 | 0 | 0 | 1      | 1 | 1 | 1 | 0 | 0 | 0 | 0 | 9CF0     |
| K1 switched to low-impedance state   | 1      | 0 | 0 | 1 | 1 | 1 | 0 | 0 | 1      | 1 | 1 | 1 | 1 | 1 | 1 | 1 | 9CFF     |
| K2 interface works as ISO9141 interface (default)  | 1      | 0 | 0 | 1 | 1 | 0 | 0 | 1 | 0      | 0 | 0 | 0 | 0 | 0 | 0 | 0 | 9900     |
| K2 interface works in LS driver mode   | 1      | 0 | 0 | 1 | 1 | 0 | 0 | 1 | 0      | 0 | 0 | 0 | 1 | 1 | 1 | 1 | 990F     |
| K2 switched to high-ohmic state (default)  | 1      | 0 | 0 | 1 | 1 | 1 | 0 | 0 | 0      | 0 | 0 | 0 | 0 | 0 | 0 | 0 | 9C00     |
| K2 switched to low-impedance state   | 1      | 0 | 0 | 1 | 1 | 1 | 0 | 0 | 0      | 0 | 0 | 0 | 1 | 1 | 1 | 1 | 9C0F     |

Because the K1 and K2 interfaces are by default switched to ISO (LIN) mode, the commands 9CF0, 9CFF, 9C00, and 9C0F default to invalid commands.

**Table 22-6.** Initial Programming (IP Command)

| Description               | MSByte |   |   |   |   |   |   |   | LSByte |   |   |   |   |   |   |   | Hex Code |
|---------------------------|--------|---|---|---|---|---|---|---|--------|---|---|---|---|---|---|---|----------|
|                           | 7      | 6 | 5 | 4 | 3 | 2 | 1 | 0 | 7      | 6 | 5 | 4 | 3 | 2 | 1 | 0 |          |
| Write data to IP register | 1      | 0 | 1 | 0 | 1 | 0 | 0 | 1 | x      | x | x | x | x | x | x | x | A9xx     |

The initial programming command is only available in Test mode. For more information about the programming flow and the register contents, see [Section 5.2 "Initial Programming of the ATA6264"](#) on page 11.

**Table 22-7.** Diagnosis Commands

| Description  | MSByte |   |   |   |   |   |   |   | LSByte |   |   |   |   |   |   |   | Hex Code |
|--|--------|---|---|---|---|---|---|---|--------|---|---|---|---|---|---|---|----------|
|  | 7      | 6 | 5 | 4 | 3 | 2 | 1 | 0 | 7      | 6 | 5 | 4 | 3 | 2 | 1 | 0 |          |
| Set UZP to tristate mode and switch off all measurements | 1      | 1 | 0 | 0 | 0 | 0 | 0 | 0 | 0      | 0 | 0 | 0 | 0 | 0 | 0 | 0 | C000     |
| Switch $V_{EVZ}$ via AMUX to UZP                         | 1      | 1 | 0 | 0 | 1 | 0 | 1 | 0 | 0      | 0 | 1 | 1 | 0 | 0 | 0 | 1 | CA31     |
| Switch $V_{VSAT}$ via AMUX to UZP                        | 1      | 1 | 0 | 0 | 1 | 0 | 1 | 0 | 0      | 0 | 1 | 1 | 0 | 0 | 1 | 0 | CA32     |
| Switch $90\% \times V_{VPERI}$ via AMUX to UZP           | 1      | 1 | 0 | 0 | 1 | 0 | 1 | 0 | 0      | 0 | 1 | 1 | 0 | 1 | 0 | 0 | CA34     |
| Switch $10\% \times V_{VPERI}$ via AMUX to UZP           | 1      | 1 | 0 | 0 | 1 | 0 | 1 | 0 | 0      | 0 | 1 | 1 | 1 | 0 | 0 | 0 | CA38     |
| Switch $V_{V_{CORE}}$ via AMUX to UZP                    | 1      | 1 | 0 | 0 | 1 | 0 | 1 | 0 | 0      | 1 | 1 | 0 | 0 | 0 | 0 | 1 | CA61     |
| Switch $V_{K15}$ via AMUX to UZP                         | 1      | 1 | 0 | 0 | 1 | 0 | 1 | 0 | 0      | 1 | 1 | 0 | 0 | 0 | 1 | 0 | CA62     |
| Switch $V_{K30}$ via AMUX to UZP                         | 1      | 1 | 0 | 0 | 1 | 0 | 1 | 0 | 0      | 1 | 1 | 0 | 0 | 1 | 0 | 0 | CA64     |
| Switch $V_{I_{REF}}$ via AMUX to UZP                     | 1      | 1 | 0 | 0 | 1 | 0 | 1 | 0 | 0      | 1 | 1 | 0 | 1 | 0 | 0 | 0 | CA68     |
| Switch $V_{I_{ASG1}}$ via AMUX to UZP                    | 1      | 1 | 0 | 0 | 1 | 0 | 1 | 0 | 1      | 0 | 0 | 1 | 0 | 0 | 1 | 0 | CA92     |
| Switch $V_{I_{ASG2}}$ via AMUX to UZP                    | 1      | 1 | 0 | 0 | 1 | 0 | 1 | 0 | 1      | 0 | 0 | 1 | 0 | 1 | 0 | 0 | CA94     |
| Switch $V_{I_{ASG3}}$ via AMUX to UZP                    | 1      | 1 | 0 | 0 | 1 | 0 | 1 | 0 | 1      | 0 | 0 | 1 | 1 | 0 | 0 | 0 | CA98     |
| Switch $V_{I_{ASG4}}$ via AMUX to UZP                    | 1      | 1 | 0 | 0 | 1 | 0 | 1 | 0 | 1      | 1 | 0 | 0 | 0 | 0 | 0 | 1 | CAC1     |
| Switch $V_{I_{ASG5}}$ via AMUX to UZP                    | 1      | 1 | 0 | 0 | 1 | 0 | 1 | 0 | 1      | 1 | 0 | 0 | 0 | 0 | 1 | 0 | CAC2     |
| Switch $V_{USP}$ via AMUX to UZP                         | 1      | 1 | 0 | 0 | 1 | 0 | 1 | 0 | 1      | 1 | 0 | 0 | 0 | 1 | 0 | 0 | CAC4     |
| Switch $V_{K1}$ via AMUX to UZP                          | 1      | 1 | 0 | 0 | 1 | 0 | 1 | 0 | 1      | 1 | 0 | 0 | 1 | 0 | 0 | 0 | CAC8     |
| Switch $V_{K2}$ via AMUX to UZP                          | 1      | 1 | 0 | 0 | 1 | 0 | 1 | 0 | 1      | 1 | 1 | 0 | 0 | 0 | 0 | 1 | CAE1     |

Note: 1. UZP voltage will be influenced by the USP voltage



**Table 22-7.** Diagnosis Commands (Continued)

| Description   | MSByte |   |   |   |   |   |   |   | LSByte |   |   |   |   |   |   |   | Hex Code            |
|---|--------|---|---|---|---|---|---|---|--------|---|---|---|---|---|---|---|---------------------|
|   | 7      | 6 | 5 | 4 | 3 | 2 | 1 | 0 | 7      | 6 | 5 | 4 | 3 | 2 | 1 | 0 |                     |
| Switch $V_{VINT}$ via AMUX to UZP                         | 1      | 1 | 0 | 0 | 1 | 0 | 1 | 0 | 1      | 1 | 1 | 0 | 0 | 0 | 1 | 0 | CAE2                |
| Switch voltage at chip-temperature sensor via AMUX to UZP | 1      | 1 | 0 | 0 | 1 | 0 | 1 | 0 | 1      | 1 | 1 | 0 | 0 | 1 | 0 | 0 | CAE4 <sup>(1)</sup> |

Note: 1. UZP voltage will be influenced by the USP voltage

Because the diagnosis commands are non-latching commands, any new serial interface commands, except watchdog triggering (6A55) and the Kx switching commands (9Cxx), interrupt the diagnosis.

**Table 22-8.** IASG Commands

| Description                                | MSByte |   |   |   |   |   |   |   | LSByte |   |   |   |   |   |   |   | Hex Code |
|--|--------|---|---|---|---|---|---|---|--------|---|---|---|---|---|---|---|----------|
|  | 7      | 6 | 5 | 4 | 3 | 2 | 1 | 0 | 7      | 6 | 5 | 4 | 3 | 2 | 1 | 0 |          |
| IASGx switched to 10V (mirror factor 10:1) | 1      | 1 | 1 | 1 | 0 | a | b | c | 0      | 0 | 1 | 1 | 0 | 0 | 1 | 1 | Fx33     |
| IASGx switched to 10V (mirror factor 15:1) | 1      | 1 | 1 | 1 | 0 | a | b | c | 0      | 0 | 1 | 1 | 1 | 1 | 0 | 0 | Fx3C     |
| IASGx switched to 5V (mirror factor 10:1)  | 1      | 1 | 1 | 1 | 0 | a | b | c | 1      | 1 | 0 | 0 | 0 | 0 | 1 | 1 | FxC3     |
| IASGx switched to 5V (mirror factor 15:1)  | 1      | 1 | 1 | 1 | 0 | a | b | c | 1      | 1 | 0 | 0 | 1 | 1 | 0 | 0 | FxCC     |

Note: a, b, and c represent the IASG number in binary format; only 001 = IASG1, 010 = IASG2, 011 = IASG3, 100 = IASG4, and 101 = IASG5 are valid commands

**Table 22-9.** Example

| Description                                | MSByte |   |   |   |   |   |   |   | LSByte |   |   |   |   |   |   |   | Hex Code |
|--|--------|---|---|---|---|---|---|---|--------|---|---|---|---|---|---|---|----------|
|  | 7      | 6 | 5 | 4 | 3 | 2 | 1 | 0 | 7      | 6 | 5 | 4 | 3 | 2 | 1 | 0 |          |
| IASG1 switched to 10V (mirror factor 10:1) | 1      | 1 | 1 | 1 | 0 | 0 | 0 | 1 | 0      | 0 | 1 | 1 | 0 | 0 | 1 | 1 | F133     |
| IASG5 switched to 5V (mirror factor 15:1)  | 1      | 1 | 1 | 1 | 0 | 1 | 0 | 1 | 1      | 1 | 0 | 0 | 1 | 1 | 0 | 0 | F5CC     |

Because the IASG commands are non-latching commands, any new serial interface command, except watchdog triggering (6A55) and the Kx switching commands (9Cxx), interrupts the IASG function.

## 22.3 Serial Interface Status Register

For all serial interface commands except the test-mode commands (55AAh, AA55h, 5500h), the ATA6264 status is available at the MISO line. For the status register a 16-bit structure is used, one bit for each information.

**Table 22-10.** Status Register

| Byte A |    |    |    |       |    |    |    | Byte B |    |    |    |       |    |    |    |
|--------|----|----|----|-------|----|----|----|--------|----|----|----|-------|----|----|----|
| MSBit  |    |    |    | LSBit |    |    |    | MSBit  |    |    |    | LSBit |    |    |    |
| a7     | a6 | a5 | a4 | a3    | a2 | a1 | a0 | b7     | b6 | b5 | b4 | b3    | b2 | b1 | b0 |

**Table 22-11.** Information Provided by the Itemized Bits of the Status Register

| Bit | Set To | Information   |
|-----|--------|---|
| a7  | High   | Chip temperature reports overtemperature  |
|     | Low    | Chip temperature reports normal temperature   |
| a6  | High   | Overtemperature at K1 output  |
|     | Low    | Normal temperature at K1 output   |
| a5  | High   | Overtemperature at K2 output  |
|     | Low    | Normal temperature at K2 output   |
| a4  | High   | Latch for GKEY function is set  |
|     | Low    | Latch for GKEY function is not set  |
| a3  | High   | EVZ switched to 33V, EVZ switched to external divider                               |
|     | Low    | EVZ switched to 23V   |
| a2  | High   | CP-OUT switch is low impedance  |
|     | Low    | CP-OUT switch is high ohmic   |
| a1  | High   | CP-OUT voltage too low  |
|     | Low    | CP-OUT voltage is in correct voltage range  |
| a0  | High   | CP voltage too low  |
|     | Low    | CP voltage is in correct voltage range  |
| b7  | High   | Voltage at pin USP above detection threshold  |
|     | Low    | Voltage at pin USP below detection threshold  |
| b6  | High   | GND A or GND B disconnected   |
|     | Low    | GND A and GND B connected   |
| b5  | High   | Previously sent serial interface command was invalid (default after power-on reset) |
|     | Low    | Previously sent serial interface command was valid                                  |
| b4  | High   | Error during last serial interface transmission (default after power-on reset)      |
|     | Low    | No error during last serial interface transmission                                  |
| b3  | High   | IC is in Test mode  |
|     | Low    | IC is in Normal mode  |
| b2  |        | Reflects bit b2 of the watchdog prescaler   |
| b1  |        | Reflects bit b1 of the watchdog prescaler   |
| b0  |        | Reflects bit b0 of the watchdog prescaler   |

The overtemperature bits a5, a6 and a7 are latched when overtemperature is detected. These bits will be reset with the next SPI command, unless overtemperature still exists.

In the case of a reset, bits b4 and b5 are not set to their default state. These bits show the status before reset so that the microcontroller can detect whether or not the ATA6264 is in power-up state.

**Table 22-12.** Test Command Issued via the MISO line as a Result of the Test Mode Commands

| Description | Command | MISO Answer |   |   |   |   |   |   |   |   |   |   |   |   |   |   |   | Hex Code |      |      |
|-------------|---------|-------------|---|---|---|---|---|---|---|---|---|---|---|---|---|---|---|----------|------|------|
| Test mode 1 | 55AA    | 1           | 0 | 1 | 0 | 1 | 0 | 1 | 0 | 1 | 0 | 0 | 1 | 0 | 1 | 0 | 1 | 0        | 1    | AA55 |
| Test mode 2 | AA55    | 0           | 1 | 0 | 1 | 0 | 1 | 0 | 1 | 1 | 0 | 1 | 0 | 1 | 0 | 1 | 0 | 55AA     |      |      |
| Test mode 3 | 5500    | 0           | 0 | 0 | 0 | 0 | 0 | 0 | 0 | 1 | a | b | c | d | e | f | g | h        | 01xx |      |

Note: a, b, c, d, e, f, g, h represent the contents of the Initial Programming Register



## 23. Test Mode

For better testability of the ATA6264, a test mode is implemented. This mode is activated if the pins RESQ and TxD1 are connected to GND, the pins RESQ2 and TxD2 are connected to VPERI, and the serial interface command 5A5Ah is sent to the ATA6264. Test mode is latched as long as the ATA6264 is powered ( $V_{K30} > 4.2V$  to 5V and  $V_{K15} > 3V$  to 4V). In Test mode the watchdog is disabled, which means that RESQ and RESQ2 depend on the voltage levels of the pins VCORE, VPERI and EVZ. In order to provide the programming voltage at VSAT for the initial programming,  $V_{VSAT}$  is set to 11.7V ( $\pm 0.5V$ ) in Test mode if the lock bit is not set.

After a reset, Test mode is disabled (default).

The following serial interface commands are used for the ATA6264 supplier test: E6B5(h) and E6BA(h).

**Figure 23-1.** How to Enable Test Mode

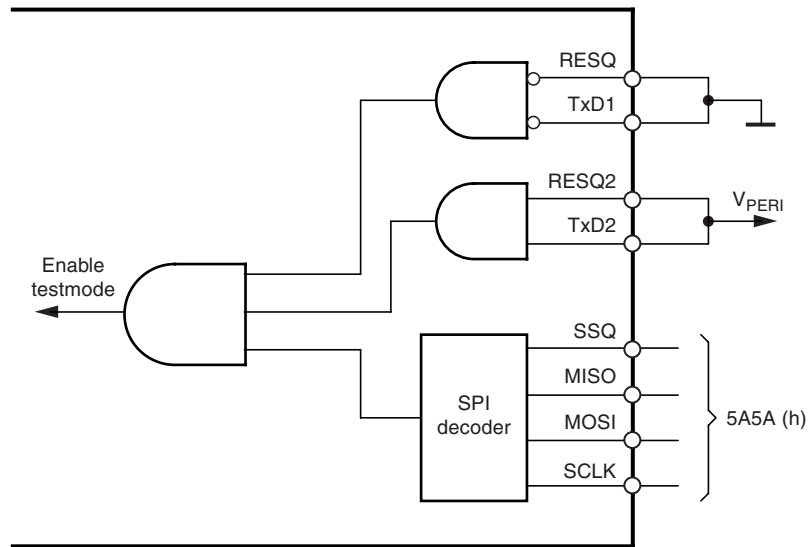

## 24. Application Circuits

Figure 24-1. Overview of a Typical Airbag System

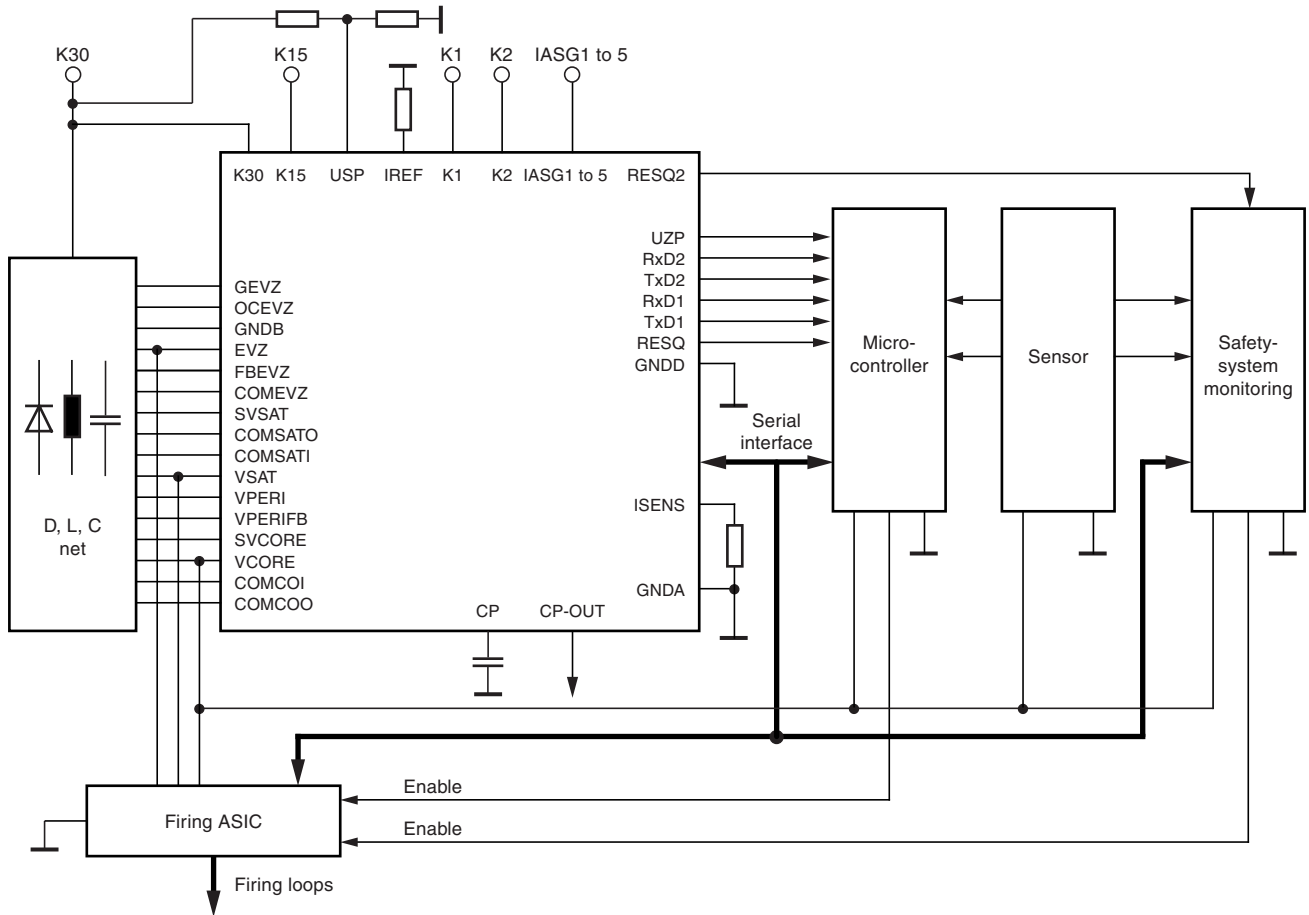
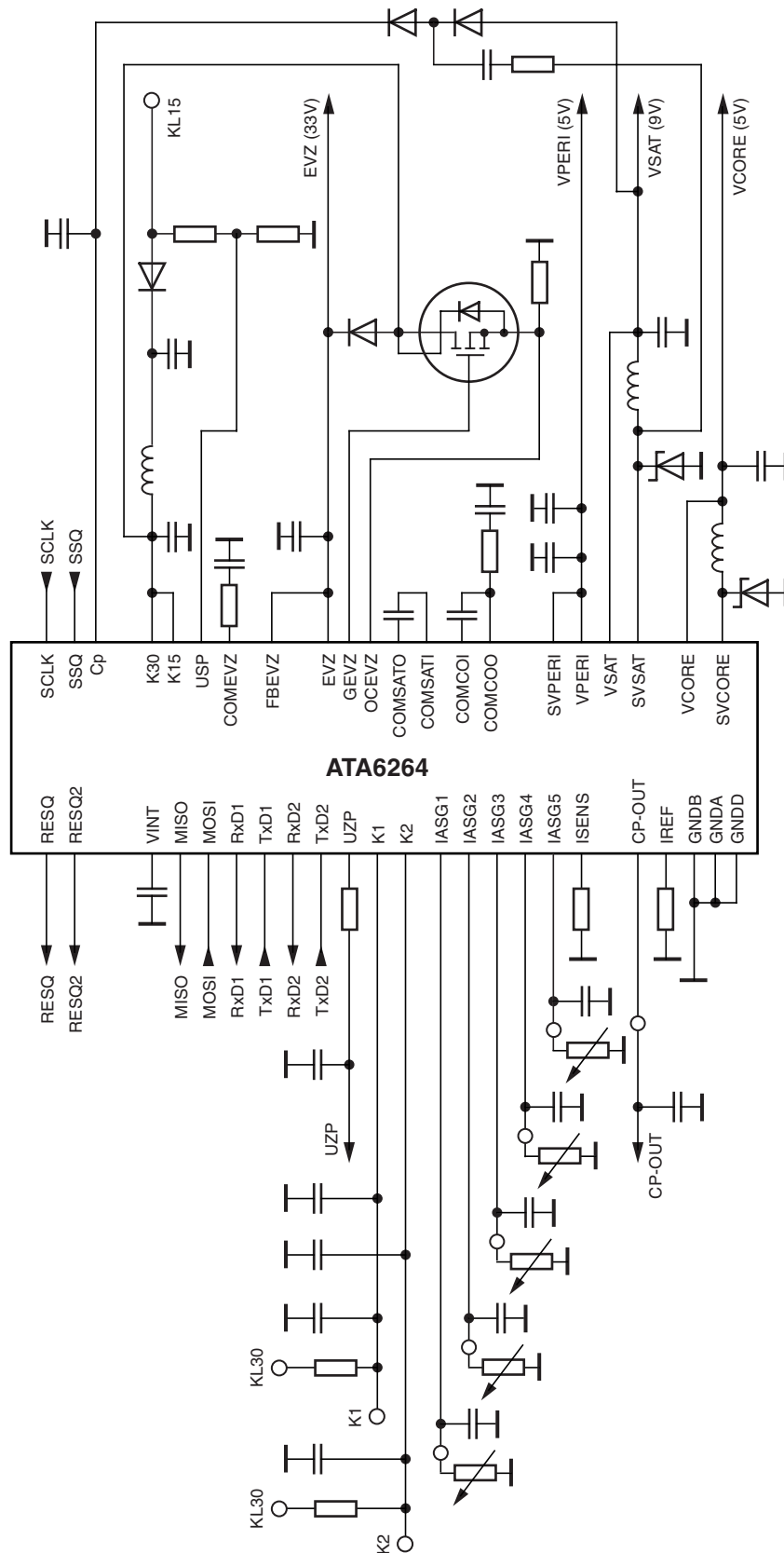

Figure 24-2. Typical Application Circuit



## 25. Ordering Information

| Extended Type Number | Package  | Remarks          |
|----------------------|----------|------------------|
| ATA6264-ALTW         | P-TQFP44 | Tray             |
| ATA6264-ALQW         | P-TQFP44 | Taped and reeled |

## 26. Package Information

Package: P-TQFP 44

(acc. JEDEC OUTLINE No. MO-112)

Dimensions in mm

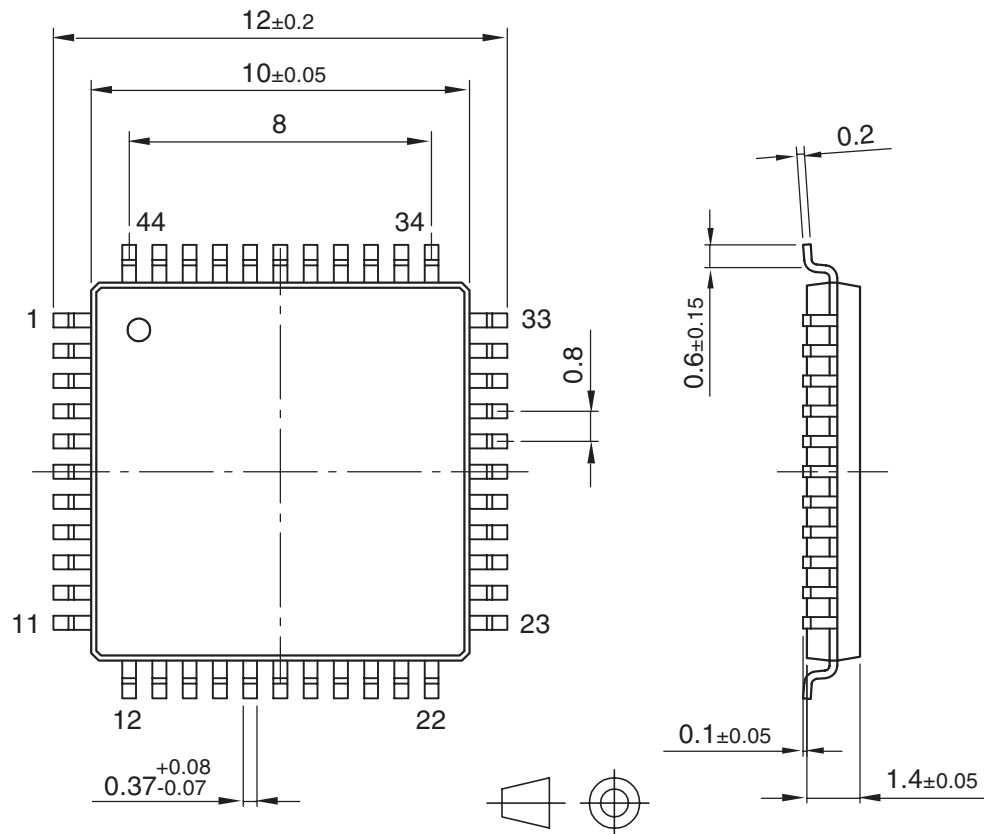

technical drawings according to DIN specifications

Drawing-No.: 6.543-5131.01-4

Issue: 1; 11.05.06

## 27. Revision History

Please note that the following page numbers referred to in this section refer to the specific revision mentioned, not to this document.

| Revision No.     | History   |
|------------------|---|
| 4929B-AUTO-01/07 | <ul style="list-style-type: none"><li>• Put datasheet in a new template</li><li>• Section 23 "Test Mode" on page 76 changed</li></ul> |



## 28. Table of Contents

|           |   |           |
|-----------|---|-----------|
|           | <b>Features .....</b>   | <b>1</b>  |
| <b>1</b>  | <b>Description .....</b>  | <b>1</b>  |
| 1.1       | Block Description .....   | 3         |
| 1.1.1     | Integrated Boost Converter EVZ .....                                | 3         |
| 1.1.2     | Integrated Buck Converter VSAT .....                                | 3         |
| 1.1.3     | Integrated Buck Converter VCORE .....                               | 3         |
| 1.1.4     | Linear Regulator VPERI .....  | 3         |
| 1.1.5     | Blocks Included .....   | 3         |
| <b>2</b>  | <b>Pin Configuration .....</b>                                      | <b>4</b>  |
| <b>3</b>  | <b>Absolute Maximum Ratings .....</b>                               | <b>6</b>  |
| <b>4</b>  | <b>Functional Range .....</b>                                       | <b>8</b>  |
| 4.1       | Protection Against Substrate Currents .....                         | 9         |
| <b>5</b>  | <b>Supply Currents .....</b>  | <b>10</b> |
| 5.1       | Discharger Circuit .....  | 11        |
| 5.2       | Initial Programming of the ATA6264 .....                            | 11        |
| 5.3       | Start-up and Power-down Procedure .....                             | 14        |
| 5.3.1     | Start-up Procedure if VVCORE is Programmed to Be 5V or 2.5V .....   | 15        |
| 5.3.2     | The Power-down Procedure Takes Place in Different Phases .....      | 15        |
| 5.3.3     | Start-up Procedure if VVCORE Programmed to Be 1.88V .....           | 16        |
| 5.3.4     | The Power-down Procedure for VVCORE is Programmed to be 1.88V ..... | 17        |
| <b>6</b>  | <b>Power Supply Sequencing .....</b>                                | <b>18</b> |
| <b>7</b>  | <b>Charge Pump .....</b>  | <b>20</b> |
| <b>8</b>  | <b>GKEY Function .....</b>  | <b>22</b> |
| <b>9</b>  | <b>EVZ Step-up Regulator .....</b>                                  | <b>24</b> |
| <b>10</b> | <b>VSAT Power Supply .....</b>                                      | <b>30</b> |
| <b>11</b> | <b>VPERI Power Supply .....</b>                                     | <b>33</b> |
| <b>12</b> | <b>VCORE Power Supply .....</b>                                     | <b>35</b> |
| <b>13</b> | <b>USP Comparator for General Purpose .....</b>                     | <b>39</b> |
| <b>14</b> | <b>Reference Voltage and Reference Current Generation .....</b>     | <b>40</b> |
| <b>15</b> | <b>Reset Function (Pin RESQ and Pin RESQ2) .....</b>                | <b>41</b> |
| <b>16</b> | <b>Watchdog Function .....</b>                                      | <b>47</b> |



|           |  |           |
|-----------|--|-----------|
| <b>17</b> | <b><i>LIN/ISO 9141 Interfaces</i></b> .....                            | <b>54</b> |
| <b>18</b> | <b><i>Voltage/Current Sources (IASGx Sources)</i></b> .....            | <b>58</b> |
| <b>19</b> | <b><i>AMUX (Analog Multiplexer for Voltage Measurements)</i></b> ..... | <b>62</b> |
| <b>20</b> | <b><i>UZP Buffer</i></b> .....   | <b>65</b> |
| <b>21</b> | <b><i>Chip Temperature Measurement</i></b> .....                       | <b>67</b> |
| <b>22</b> | <b><i>Serial Interface Commands</i></b> .....                          | <b>68</b> |
|           | 22.1 Overview .....  | 68        |
|           | 22.2 Set Commands .....  | 70        |
|           | 22.3 Serial Interface Status Register .....                            | 74        |
| <b>23</b> | <b><i>Test Mode</i></b> .....  | <b>76</b> |
| <b>24</b> | <b><i>Application Circuits</i></b> .....                               | <b>77</b> |
| <b>25</b> | <b><i>Ordering Information</i></b> .....                               | <b>79</b> |
| <b>26</b> | <b><i>Package Information</i></b> .....                                | <b>79</b> |
| <b>27</b> | <b><i>Revision History</i></b> .....                                   | <b>80</b> |



## Atmel Corporation

2325 Orchard Parkway  
San Jose, CA 95131, USA  
Tel: 1(408) 441-0311  
Fax: 1(408) 487-2600

## Regional Headquarters

### Europe

Atmel Sarl  
Route des Arsenaux 41  
Case Postale 80  
CH-1705 Fribourg  
Switzerland  
Tel: (41) 26-426-5555  
Fax: (41) 26-426-5500

### Asia

Room 1219  
Chinachem Golden Plaza  
77 Mody Road Tsimshatsui  
East Kowloon  
Hong Kong  
Tel: (852) 2721-9778  
Fax: (852) 2722-1369

### Japan

9F, Tonetsu Shinkawa Bldg.  
1-24-8 Shinkawa  
Chuo-ku, Tokyo 104-0033  
Japan  
Tel: (81) 3-3523-3551  
Fax: (81) 3-3523-7581

## Atmel Operations

### Memory

2325 Orchard Parkway  
San Jose, CA 95131, USA  
Tel: 1(408) 441-0311  
Fax: 1(408) 436-4314

### Microcontrollers

2325 Orchard Parkway  
San Jose, CA 95131, USA  
Tel: 1(408) 441-0311  
Fax: 1(408) 436-4314

La Chantrerie  
BP 70602  
44306 Nantes Cedex 3, France  
Tel: (33) 2-40-18-18-18  
Fax: (33) 2-40-18-19-60

### ASIC/ASSP/Smart Cards

Zone Industrielle  
13106 Rousset Cedex, France  
Tel: (33) 4-42-53-60-00  
Fax: (33) 4-42-53-60-01

1150 East Cheyenne Mtn. Blvd.  
Colorado Springs, CO 80906, USA  
Tel: 1(719) 576-3300  
Fax: 1(719) 540-1759

Scottish Enterprise Technology Park  
Maxwell Building  
East Kilbride G75 0QR, Scotland  
Tel: (44) 1355-803-000  
Fax: (44) 1355-242-743

### RF/Automotive

Theresienstrasse 2  
Postfach 3535  
74025 Heilbronn, Germany  
Tel: (49) 71-31-67-0  
Fax: (49) 71-31-67-2340

1150 East Cheyenne Mtn. Blvd.  
Colorado Springs, CO 80906, USA  
Tel: 1(719) 576-3300  
Fax: 1(719) 540-1759

### Biometrics

Avenue de Rochepleine  
BP 123  
38521 Saint-Egreve Cedex, France  
Tel: (33) 4-76-58-47-50  
Fax: (33) 4-76-58-47-60

---

## Literature Requests

[www.atmel.com/literature](http://www.atmel.com/literature)

**Disclaimer:** The information in this document is provided in connection with Atmel products. No license, express or implied, by estoppel or otherwise, to any intellectual property right is granted by this document or in connection with the sale of Atmel products. **EXCEPT AS SET FORTH IN ATMEL'S TERMS AND CONDITIONS OF SALE LOCATED ON ATMEL'S WEB SITE, ATMEL ASSUMES NO LIABILITY WHATSOEVER AND DISCLAIMS ANY EXPRESS, IMPLIED OR STATUTORY WARRANTY RELATING TO ITS PRODUCTS INCLUDING, BUT NOT LIMITED TO, THE IMPLIED WARRANTY OF MERCHANTABILITY, FITNESS FOR A PARTICULAR PURPOSE, OR NON-INFRINGEMENT. IN NO EVENT SHALL ATMEL BE LIABLE FOR ANY DIRECT, INDIRECT, CONSEQUENTIAL, PUNITIVE, SPECIAL OR INCIDENTAL DAMAGES (INCLUDING, WITHOUT LIMITATION, DAMAGES FOR LOSS OF PROFITS, BUSINESS INTERRUPTION, OR LOSS OF INFORMATION) ARISING OUT OF THE USE OR INABILITY TO USE THIS DOCUMENT, EVEN IF ATMEL HAS BEEN ADVISED OF THE POSSIBILITY OF SUCH DAMAGES.** Atmel makes no representations or warranties with respect to the accuracy or completeness of the contents of this document and reserves the right to make changes to specifications and product descriptions at any time without notice. Atmel does not make any commitment to update the information contained herein. Unless specifically provided otherwise, Atmel products are not suitable for, and shall not be used in, automotive applications. Atmel's products are not intended, authorized, or warranted for use as components in applications intended to support or sustain life.

© Atmel Corporation 2007. All rights reserved. Atmel®, logo and combinations thereof, Everywhere You Are® and others are registered trademarks or trademarks of Atmel Corporation or its subsidiaries. Other terms and product names may be trademarks of others.