

BLB102SURC/E12V

HYPER RED

### Features

- BUILT-IN CURRENT LIMITING RESISTOR FOR DIRECT APPLICATION OF DIFFERENT ACROSS CURRENT.
- LONG LIFE.
- LOW CURRENT, POWER SAVINGS.
- LOW MAINTENANCE.
- DIFFERENT COLOR AVAILABLE.
- SOLID STATE, HIGH VIBRATION RESISTANT.
- CONTINUOUS OPERATING LIFE 25000 HOURS AT ROOM TEMPERATURE 25 °C.
- 12V INTERNAL RESISTOR

### Description

The Hyper Red source color devices are made with DH InGaAlP on GaAs substrate Light Emitting Diode.

### Package Dimensions

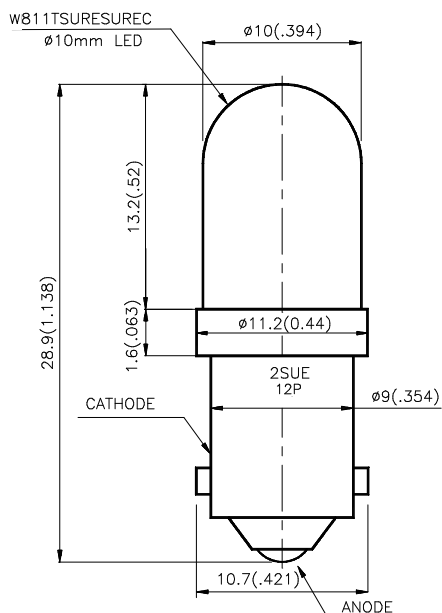

#### Notes:

1. All dimensions are in millimeters (inches).
2. Tolerance is  $\pm 0.25 (0.01)$  unless otherwise noted.
3. Specifications are subjected to change without notice.

## Selection Guide

Part No.	Dice	Lens Type	Iv (mcd) V=12V		Viewing Angle
			Min.	Typ.	θ1/2
BLB102SURC/E12V	HYPER RED (InGaAlP)	WATER CLEAR	650	1800	40°

Note:

1. θ1/2 is the angle from optical centerline where the luminous intensity is 1/2 the optical centerline value.

## Electrical / Optical Characteristics at T<sub>A</sub>=25°C

Symbol	Parameter	Device	Typ.	Max.	Units	Test Conditions
λ <sub>peak</sub>	Peak Wavelength	Hyper Red	640		nm	V <sub>F</sub> =12V
λ <sub>D</sub>	Dominate Wavelength	Hyper Red	630		nm	V <sub>F</sub> =12V
Δλ <sub>1/2</sub>	Spectral Line Half-width	Hyper Red	25		nm	V <sub>F</sub> =12V
I <sub>F</sub>	Forward Current	Hyper Red	25		mA	V <sub>F</sub> =12V
C	Capacitance	Hyper Red	45		pF	V <sub>F</sub> =0V, f=1MHz
I <sub>R</sub>	Reverse Current	Hyper Red		10	uA	V <sub>R</sub> =5V

## Absolute Maximum Ratings at T<sub>A</sub>=25°C

Parameter	Hyper Red	Units
Power dissipation	400	mW
Forward Voltage	14	V
Reverse Voltage	5	V
Operating Temperature	-40 To +70	°C
Storage Temperature	-40 To +85	°C

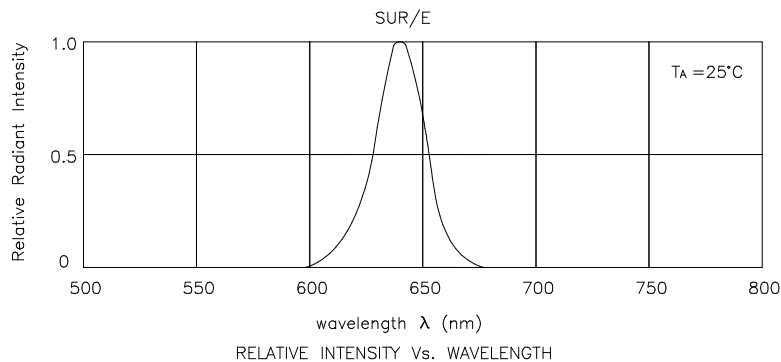

**Hyper Red**

**BLB102SURC/E12V**

