

Silicon Diffused Power Transistor

BUT12AI

GENERAL DESCRIPTION

Improved high-voltage, high-speed glass-passivated npn power transistor in a TO220AB envelope specially suited for use in overhead/high frequency lighting ballast applications and converters, inverters, switching regulators, motor control systems, etc.

QUICK REFERENCE DATA

SYMBOL	PARAMETER	CONDITIONS	TYP.	MAX.	UNIT
V_{CESM}	Collector-emitter voltage peak value	$V_{BE} = 0 \text{ V}$	-	1000	V
V_{CEO}	Collector-emitter voltage (open base)		-	450	V
I_C	Collector current (DC)		-	8	A
I_{CM}	Collector current peak value		-	20	A
P_{tot}	Total power dissipation	$T_{hs} \leq 25 \text{ }^\circ\text{C}$	-	110	W
V_{CEsat}	Collector-emitter saturation voltage	$I_C = 5 \text{ A}; I_B = 0.86 \text{ A}$	-	1.5	V
I_{Csat}	Collector saturation current		5	-	A
t_f	Inductive fall time	$I_{Con} = 5 \text{ A}; I_{Bon} = 1.0 \text{ A}; T_j \leq 100 \text{ }^\circ\text{C}$		300	ns

PINNING - TO220AB

PIN	DESCRIPTION
1	base
2	collector
3	emitter
tab	collector

PIN CONFIGURATION

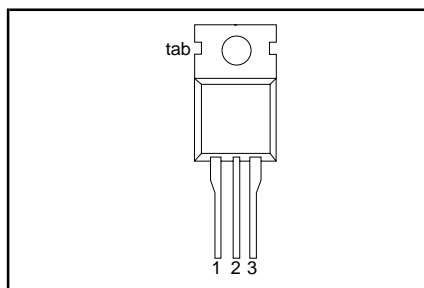

SYMBOL

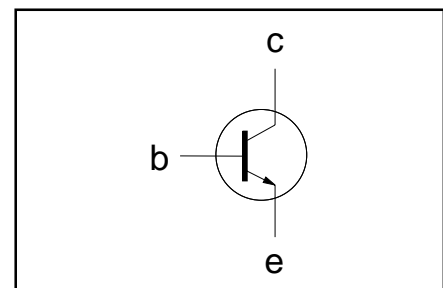

LIMITING VALUES

Limiting values in accordance with the Absolute Maximum Rating System (IEC 134)

SYMBOL	PARAMETER	CONDITIONS	MIN.	MAX.	UNIT
V_{CESM}	Collector-emitter voltage peak value	$V_{BE} = 0 \text{ V}$	-	1000	V
V_{CEO}	Collector-emitter voltage (open base)		-	450	V
I_C	Collector current (DC)		-	8	A
I_{CM}	Collector current peak value		-	20	A
I_B	Base current (DC)		-	4	A
I_{BM}	Base current peak value		-	6	A
P_{tot}	Total power dissipation	$T_{hs} \leq 25 \text{ }^\circ\text{C}$	-	110	W
T_{stg}	Storage temperature		-65	150	$^\circ\text{C}$
T_j	Junction temperature		-	150	$^\circ\text{C}$

THERMAL RESISTANCES

SYMBOL	PARAMETER	CONDITIONS	TYP.	MAX.	UNIT
$R_{th\ j-hs}$	Junction to heatsink	with heatsink compound	-	1.15	K/W
$R_{th\ j-a}$	Junction to ambient	in free air	-	60	K/W

Silicon Diffused Power Transistor

BUT12AI

STATIC CHARACTERISTICS

$T_{hs} = 25\text{ }^{\circ}\text{C}$ unless otherwise specified

SYMBOL	PARAMETER	CONDITIONS	MIN.	TYP.	MAX.	UNIT
I_{CES}	Collector cut-off current ¹	$V_{BE} = 0\text{ V}; V_{CE} = V_{CESMmax}$	-	-	1.0	mA
I_{CES}		$V_{BE} = 0\text{ V}; V_{CE} = V_{CESMmax}$ $T_j = 125\text{ }^{\circ}\text{C}$	-	-	3.0	mA
I_{EBO}	Emitter cut-off current	$V_{EB} = 9\text{ V}; I_C = 0\text{ A}$	-	-	10	mA
$V_{CEOsust}$	Collector-emitter sustaining voltage	$I_B = 0\text{ A}; I_C = 100\text{ mA};$ $L = 25\text{ mH}$	450	-	-	V
V_{CEsat}	Collector-emitter saturation voltages	$I_C = 5\text{ A}; I_B = 0.86\text{ A}$	-	-	1.5	V
V_{BEsat}		Base-emitter saturation voltage	$I_C = 5\text{ A}; I_B = 0.86\text{ A}$	-	-	1.3
h_{FE}	DC current gain	$I_C = 10\text{ mA}; V_{CE} = 5\text{ V}$	10	18	35	
h_{FE}		$I_C = 1.0\text{ A}; V_{CE} = 5\text{ V}$	14	20	35	
h_{FEsat}		$I_C = 5.0\text{ A}; V_{CE} = 1.5\text{ V}$	5.8	10	12.5	

DYNAMIC CHARACTERISTICS

$T_{hs} = 25\text{ }^{\circ}\text{C}$ unless otherwise specified

SYMBOL	PARAMETER	CONDITIONS	TYP.	MAX.	UNIT
t_{on}	Switching times (resistive load) Turn-on time Turn-off storage time Turn-off fall time	$I_{Con} = 5\text{ A}; I_{Bon} = -I_{Boff} = 1.0\text{ A}$	-	1.0	μs
t_s			-	4.0	μs
t_f			-	0.8	μs
t_s	Switching times (inductive load) Turn-off storage time Turn-off fall time	$I_{Con} = 5\text{ A}; I_{Bon} = 1.0\text{ A}; L_B = 1\text{ }\mu\text{H};$ $-V_{BB} = 5\text{ V}; T_j = 100\text{ }^{\circ}\text{C}$	1.9	2.5	μs
t_f			150	300	ns

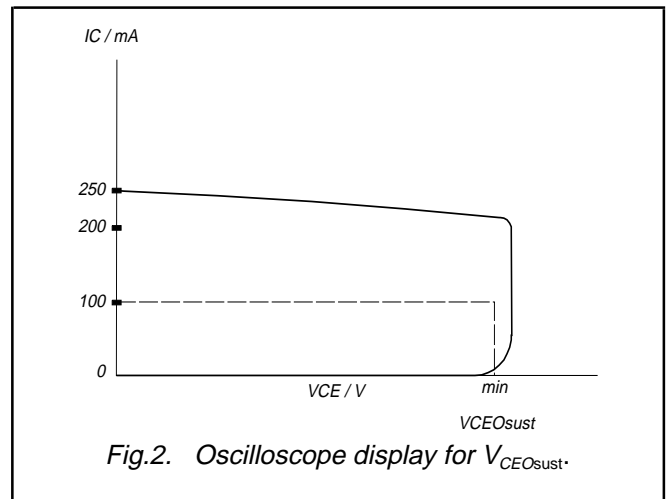
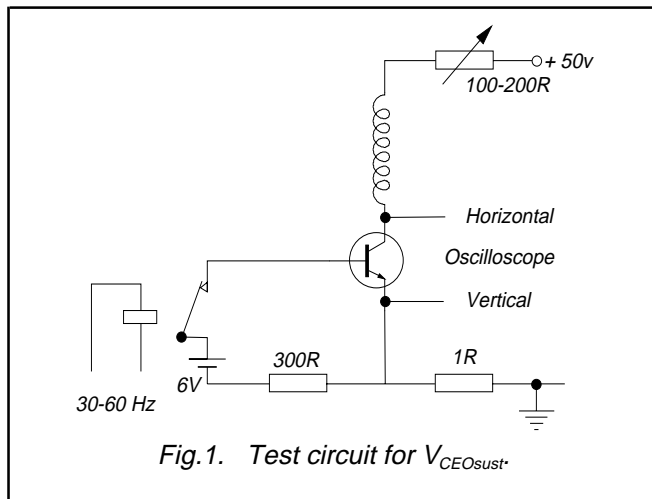

¹ Measured with half sine-wave voltage (curve tracer).

Silicon Diffused Power Transistor

BUT12AI

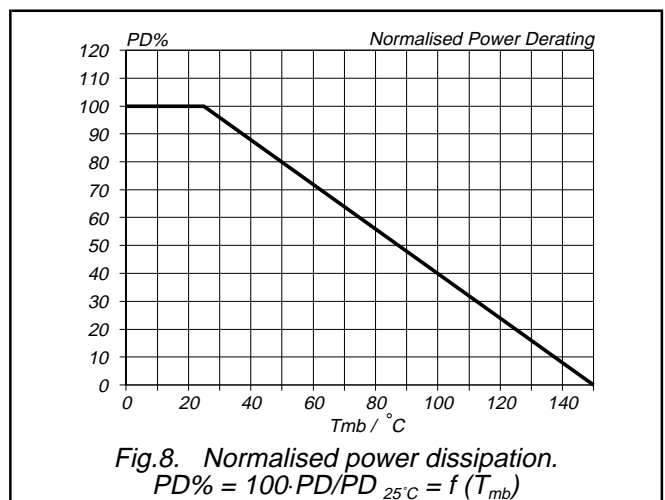
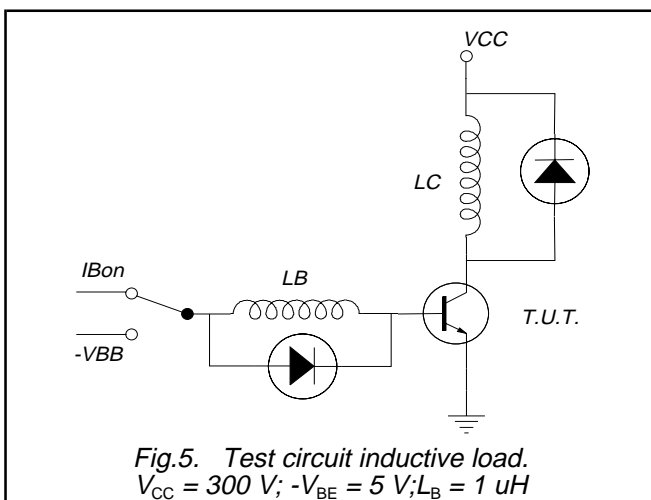
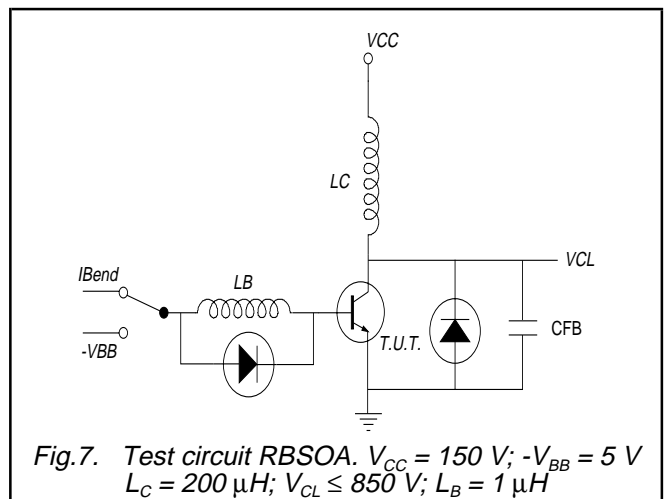
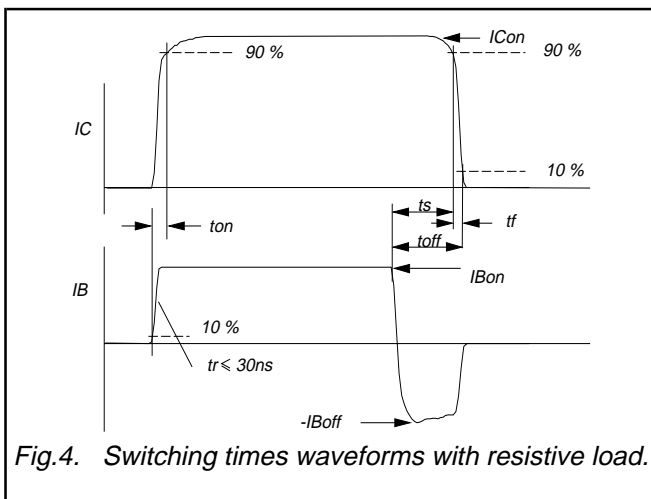
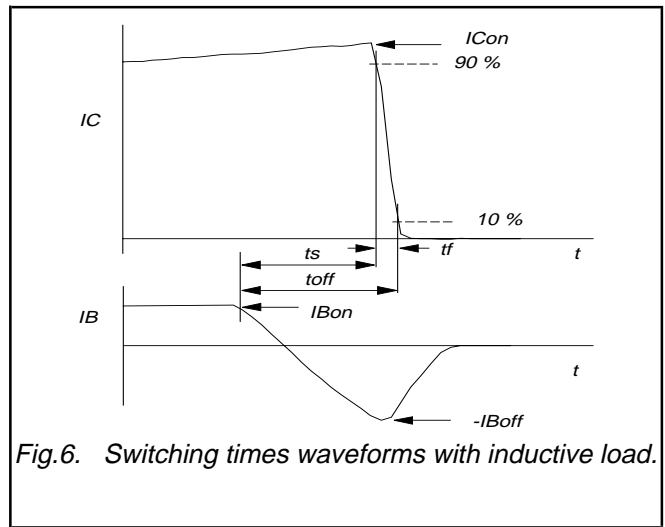
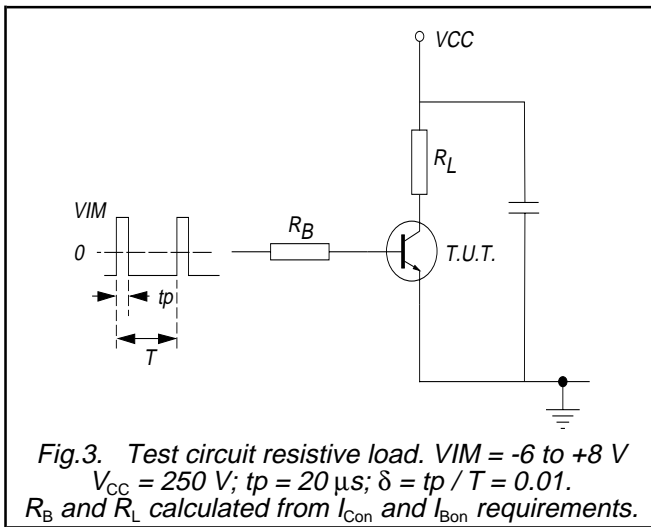

Silicon Diffused Power Transistor

BUT12AI

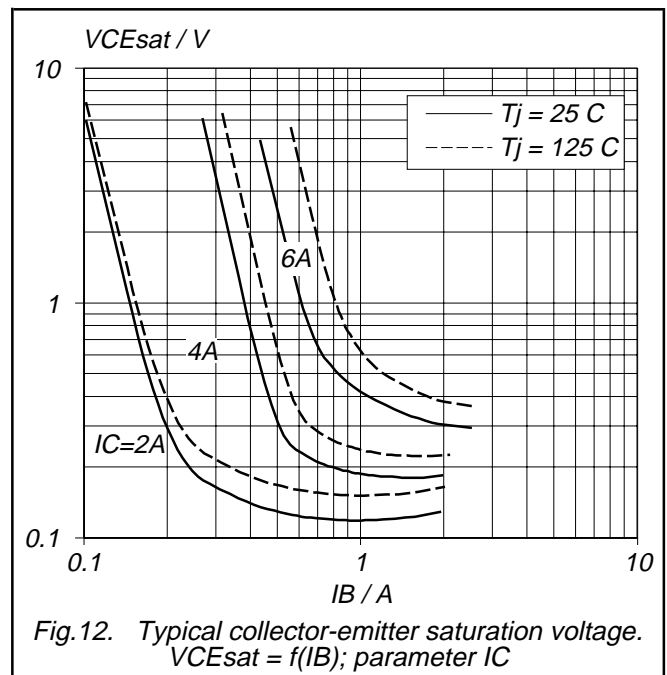
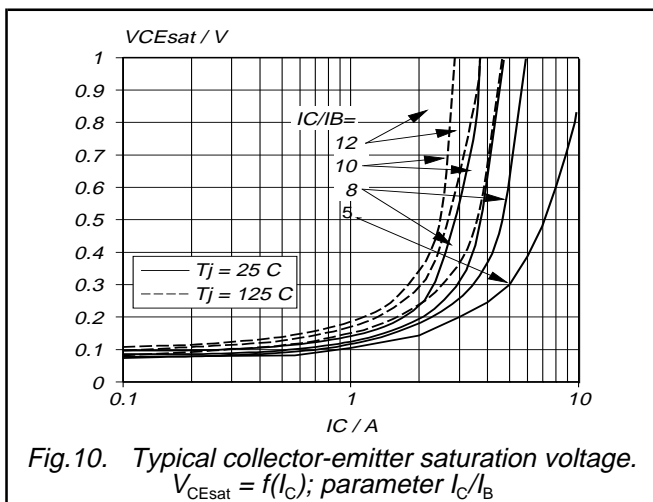
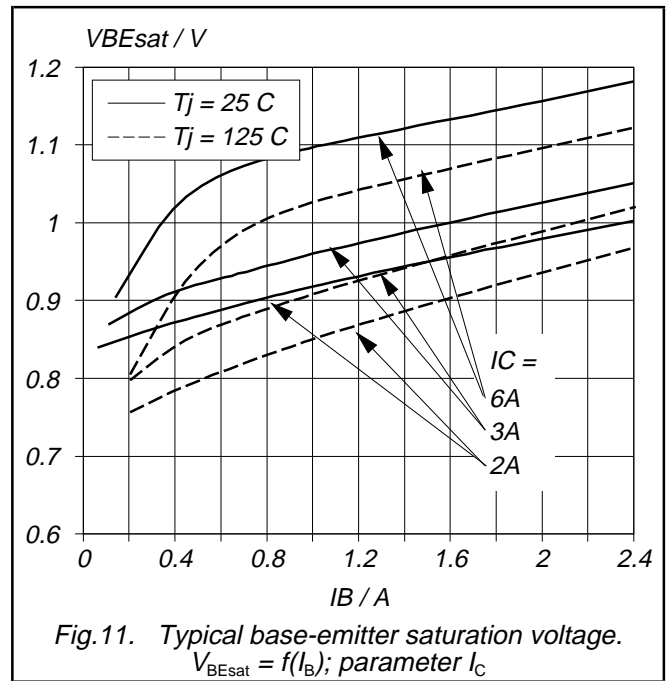
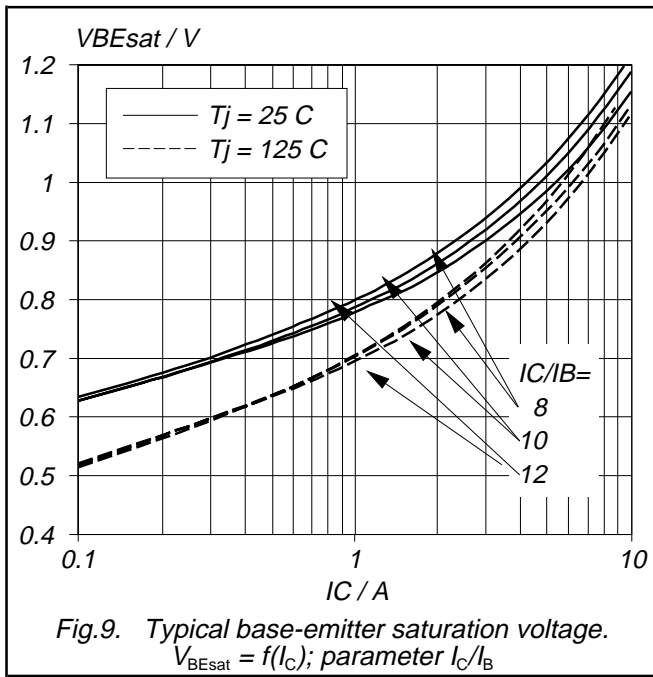

Silicon Diffused Power Transistor

BUT12AI

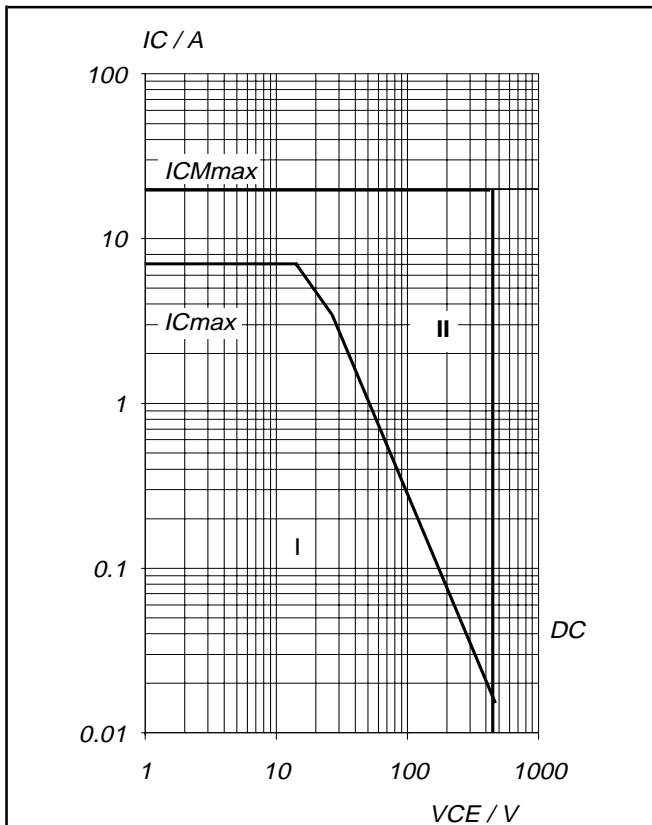

Fig. 13. Forward bias safe operating area. $T_{mb} = 25^{\circ}\text{C}$

- I Region of permissible DC operation.
- II Extension for repetitive pulse operation.
- NB: Mounted with heatsink compound and 30 ± 5 newton force on the centre of the envelope.

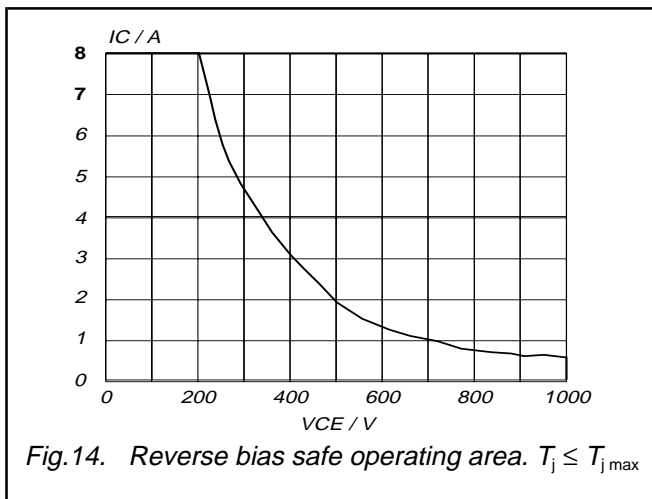

Fig. 14. Reverse bias safe operating area. $T_j \leq T_{j\text{max}}$

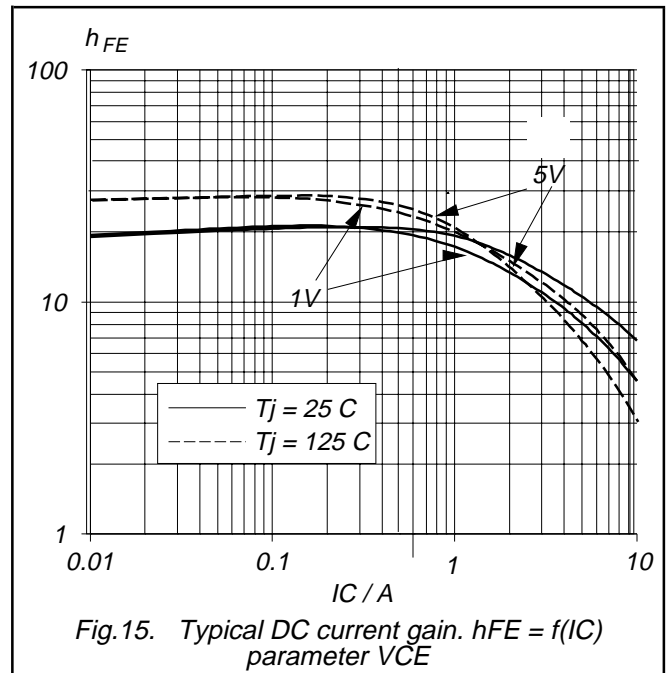

Fig. 15. Typical DC current gain. $h_{FE} = f(I_C)$ parameter V_{CE}

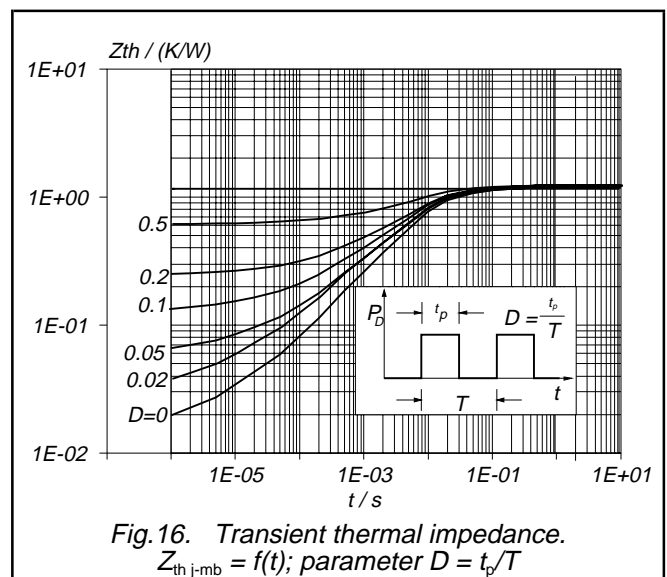
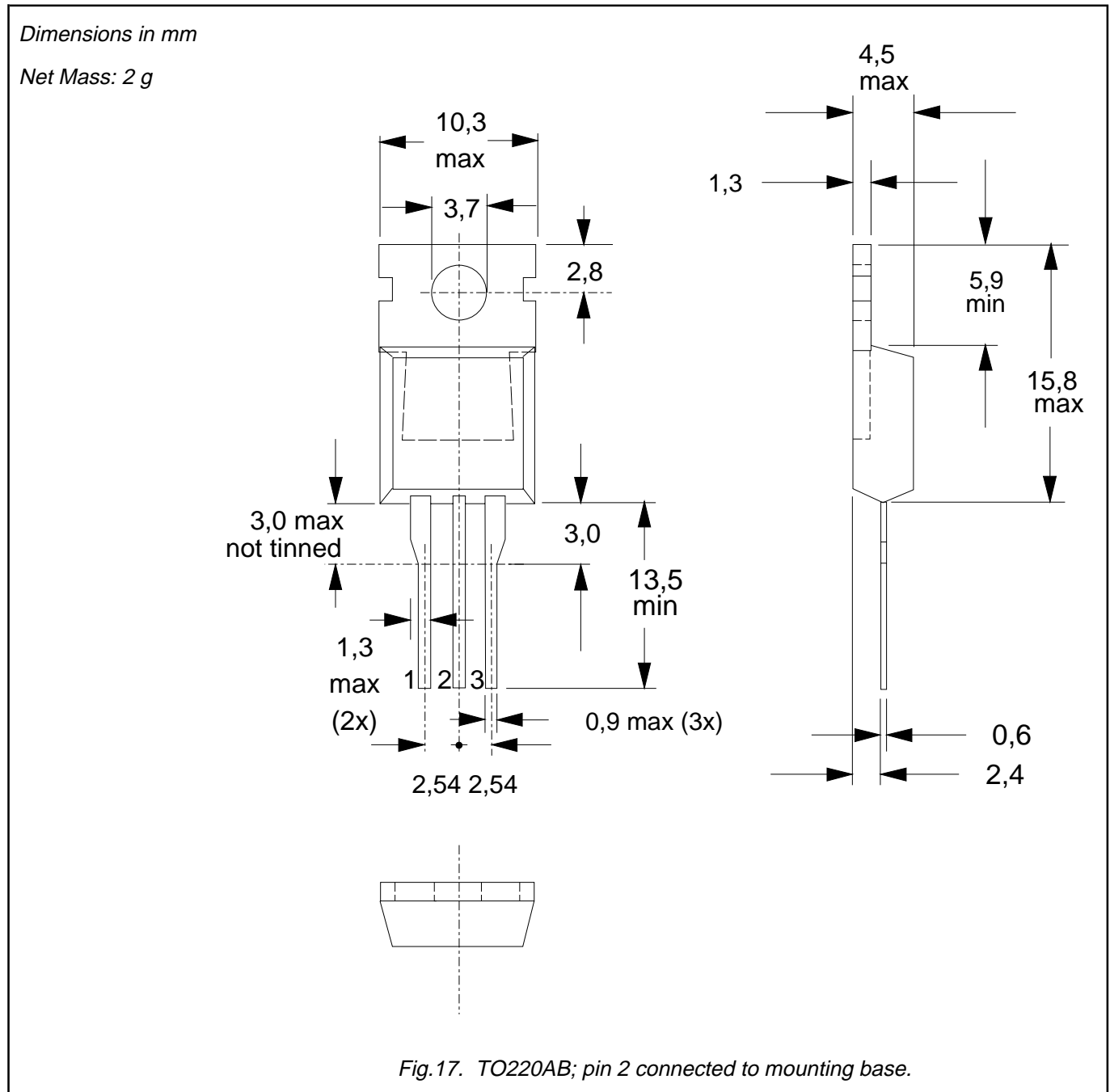

Fig. 16. Transient thermal impedance. $Z_{th-jmb} = f(t)$; parameter $D = t_p/T$

Silicon Diffused Power Transistor

BUT12AI

MECHANICAL DATA



Notes

1. Refer to mounting instructions for TO220 envelopes.
2. Epoxy meets UL94 V0 at 1/8".

Silicon Diffused Power Transistor

BUT12AI

DEFINITIONS

Data sheet status	
Objective specification	This data sheet contains target or goal specifications for product development.
Preliminary specification	This data sheet contains preliminary data; supplementary data may be published later.
Product specification	This data sheet contains final product specifications.
Limiting values	
Limiting values are given in accordance with the Absolute Maximum Rating System (IEC 134). Stress above one or more of the limiting values may cause permanent damage to the device. These are stress ratings only and operation of the device at these or at any other conditions above those given in the Characteristics sections of this specification is not implied. Exposure to limiting values for extended periods may affect device reliability.	
Application information	
Where application information is given, it is advisory and does not form part of the specification.	
© Philips Electronics N.V. 1997	
All rights are reserved. Reproduction in whole or in part is prohibited without the prior written consent of the copyright owner.	
The information presented in this document does not form part of any quotation or contract, it is believed to be accurate and reliable and may be changed without notice. No liability will be accepted by the publisher for any consequence of its use. Publication thereof does not convey nor imply any license under patent or other industrial or intellectual property rights.	

LIFE SUPPORT APPLICATIONS

These products are not designed for use in life support appliances, devices or systems where malfunction of these products can be reasonably expected to result in personal injury. Philips customers using or selling these products for use in such applications do so at their own risk and agree to fully indemnify Philips for any damages resulting from such improper use or sale.