

# Design Idea DI-17

## TOPSwitch-GX<sup>®</sup>

### 17 W, PC Standby



Application	Device	Power Output	Input Voltage	Output Voltage	Topology
PC Standby	TOP242Y	17 W	200-375 VDC	3.3 V / 5 V	Flyback

## Design Highlights

- Meets Blue Angel efficiency requirements providing output power of 3.9 W with 5 W input power
- Input undervoltage (UV) detect eliminates power-up/down output glitches
- 132 kHz switching frequency allows small, low cost EEL19 based transformer to deliver 17 W
- Regulation derived from 3.3 V and 5 V outputs ensuring  $\pm 5\%$  regulation on both outputs
- 15 V output for primary side circuitry
- Primary soft-start minimizes start-up component stresses

## Operation

The design in Figure 1 utilizes the TOP242Y and takes advantage of many of the device's features. Input UV is set at 195 VDC using a single 3.9 M $\Omega$  resistor (R1). On increasing input

voltage, the supply is disabled until 195 VDC is reached (this threshold is typically the lowest operating DC input voltage for a PC main power supply with a doubler input configuration). On decreasing input voltage the supply continues to operate until regulation is lost, even if this is below the UV threshold. Once regulation is lost the input voltage has to exceed the UV threshold again before the supply is enabled.

During the first 10 ms of operation internal soft-start is enabled. The duty cycle is linearly increased from 0% to 78% and the current limit from 70% to 100%, lowering stresses on the internal power MOSFET, clamp and output rectifier. Diode D1 and Zener VR1 are used to clamp the leading-edge drain-voltage spikes caused by transformer leakage inductance. At light load, a Zener clamp provides

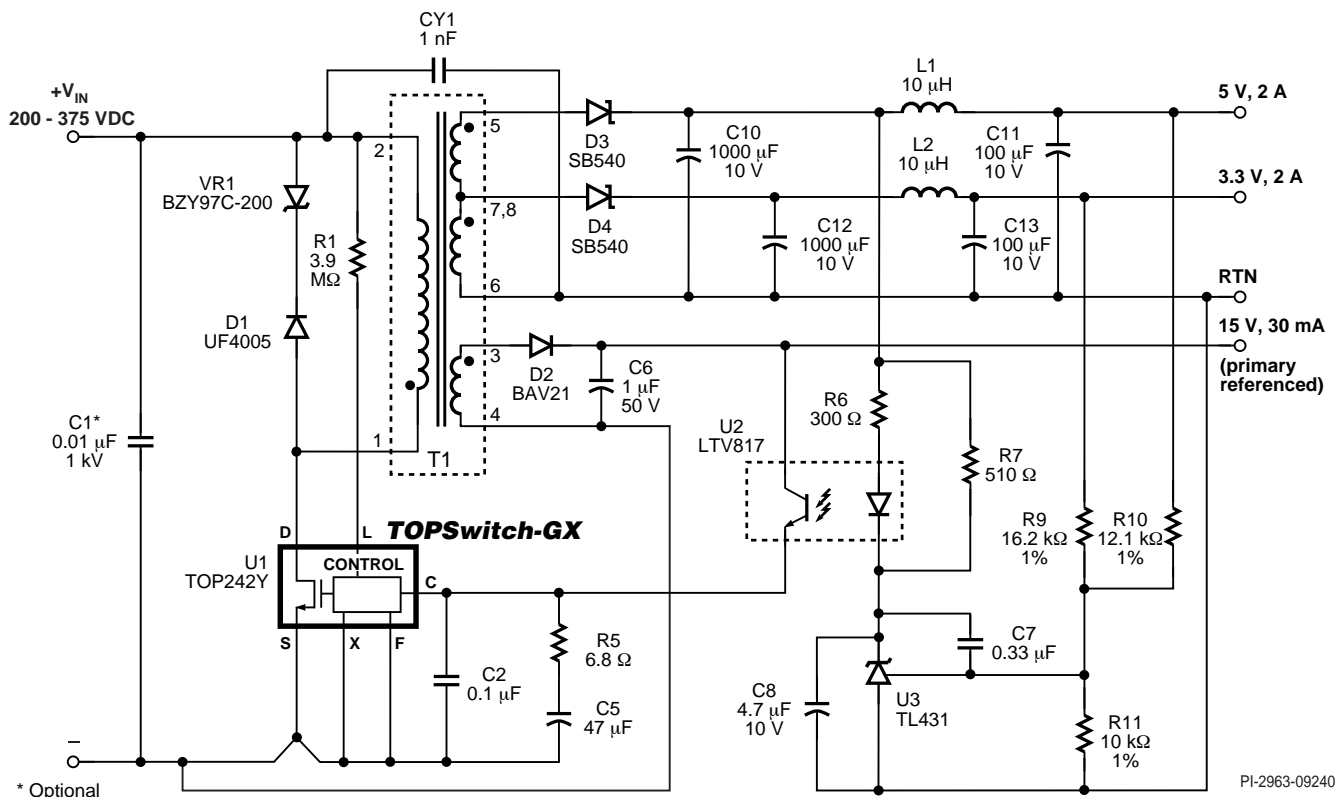

PI-2963-092402

Figure 1. TOPSwitch-GX 17 W PC Standby.

higher efficiency than an RCD clamp, maximizing available output power for the Blue Angel 5 W input power limit.

A secondary shunt regulator (U3) together with R6, R7, R9, R10 and R11 are used to sense both the 3.3 V and 5 V outputs. Control loop compensation is accomplished with capacitor C7, R5 and C5. Resistor R6 sets the DC gain while R7 provides bias to the TL431 (U3). The values shown provided satisfactory phase margin and bandwidth.

## Key Design Points

- Decoupling capacitor (C1) should be used if the standby supply is far from the main input bulk capacitor.
- The value of R1 is set according to the equation:  

$$R1 = (V_{UV} - 2.5)/50 \mu A.$$
- Minimize secondary trace leakage inductance to improve output cross regulation.
- Y1 capacitor (CY1) should be connected between secondary return and primary positive DC rail to minimize potential coupling into the *TOPSwitch-GX* SOURCE pin during common mode line surge events.
- Connect bias winding return past SOURCE pin to route common mode surge currents away from *TOPSwitch-GX*.
- A soft-finish capacitor (C8) eliminates output start-up overshoot.
- Capacitor C2 should be located close to U1.

TRANSFORMER PARAMETERS	
Core Material	EEL19 (Nippon Ceramic NC-2H) $A_{LG} = 720 \text{ nH/T}^2$
Bobbin	EEL19 8 pin (TDK BE-9-118CPH or equivalent)
Winding Details	Primary: 147T x 34 AWG Bias: 17T x 34 AWG 3.3 V: 4T x 3 x 27 AWG T.I.W. 5.0 V: 2T x 3 x 27 AWG T.I.W. (T.I.W. = Triple Insulated Wire)
Winding Order (Pin Numbers)	Primary (1-2), tape, 3.3 V (7, 8-6), 5 V (5-7, 8), tape Bias (3-4), tape
Inductance	Primary: 2.3 mH $\pm 10\%$ , Leakage: 75 $\mu\text{H}$ (maximum)
Primary Resonant Frequency	650 kHz (minimum)

Table 1. Transformer Construction Information.

For the latest updates, visit our Web site: [www.powerint.com](http://www.powerint.com)

Power Integrations reserves the right to make changes to its products at any time to improve reliability or manufacturability. Power Integrations does not assume any liability arising from the use of any device or circuit described herein, nor does it convey any license under its patent rights or the rights of others. The products and applications illustrated herein (including circuits external to the products and transformer construction) may be covered by one or more U.S. and foreign patents or potentially by pending U.S. and foreign patent applications assigned to Power Integrations. A complete list of Power Integrations' patents may be found at [www.powerint.com](http://www.powerint.com).

The PI Logo, **TOPSwitch**, **TinySwitch**, **LinkSwitch** and **EcoSmart** are registered trademarks of Power Integrations, Inc. **PI Expert** is a trademark of Power Integrations, Inc. ©Copyright 2002, Power Integrations, Inc.

### WORLD HEADQUARTERS AMERICAS

Power Integrations, Inc.  
San Jose, CA 95138 USA  
Customer Service:  
Phone: +1 408-414-9665  
Fax: +1 408-414-9765  
e-mail: [usasales@powerint.com](mailto:usasales@powerint.com)

### CHINA

Power Integrations International  
Holdings, Inc.  
China  
Phone: +86-755-8367-5143  
Fax: +86-755-8377-9610  
e-mail: [chinasales@powerint.com](mailto:chinasales@powerint.com)

### EUROPE & AFRICA

Power Integrations (Europe) Ltd.  
United Kingdom  
Phone: +44-1344-462-300  
Fax: +44-1344-311-732  
e-mail: [eurosales@powerint.com](mailto:eurosales@powerint.com)

### KOREA

Power Integrations  
International Holdings, Inc.  
Seoul, Korea  
Phone: +82-2-782-2840  
Fax: +82-2-782-4427  
e-mail: [koreasales@powerint.com](mailto:koreasales@powerint.com)

### SINGAPORE

Power Integrations, Singapore  
Republic of Singapore 308900  
Phone: +65-6358-2160  
Fax: +65-6358-2015  
e-mail: [singaporesales@powerint.com](mailto:singaporesales@powerint.com)

### JAPAN

Power Integrations, K.K.  
Keihin-Tatemono 1st Bldg.  
Japan  
Phone: +81-45-471-1021  
Fax: +81-45-471-3717  
e-mail: [japansales@powerint.com](mailto:japansales@powerint.com)

### APPLICATIONS HOTLINE

World Wide +1-408-414-9660

### TAIWAN

Power Integrations  
International Holdings, Inc.  
Taipei, Taiwan  
Phone: +886-2-2727-1221  
Fax: +886-2-2727-1223  
e-mail: [taiwansales@powerint.com](mailto:taiwansales@powerint.com)

### INDIA (Technical Support)

Innovatech  
Bangalore, India  
Phone: +91-80-226-6023  
Fax: +91-80-228-9727  
e-mail: [indiasales@powerint.com](mailto:indiasales@powerint.com)

### APPLICATIONS FAX

World Wide +1-408-414-9760

