

IL33153

SINGLE IGBT GATE DRIVER

The IL33153 is specifically designed as an IGBT driver for high power applications that include ac induction motor control, brushless dc motor control and uninterruptable power supplies. Although designed for driving discrete and module IGBTs, this device offers a cost effective solution for driving power MOSFETs and Bipolar Transistors. Device protection features include the choice of desaturation or overcurrent sensing and undervoltage detection. These devices are available in dual-inline and surface mount packages and include the following features:

FEATURES

- High Current Output Stage: 1.0 A Source/2.0 A Sink
- Protection Circuits for Both Conventional and Sense IGBTs
- Programmable Fault Blanking Time
- Protection against Overcurrent and Short Circuit
- Undervoltage Lockout Optimized for IGBT's
- Negative Gate Drive Capability
- Cost Effectively Drives Power MOSFETs and Bipolar Transistors

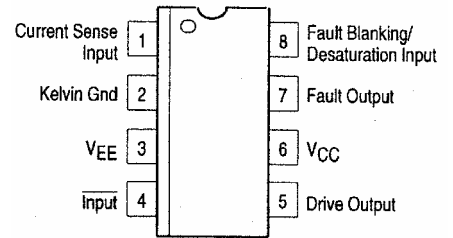

BLOCK SCHEME

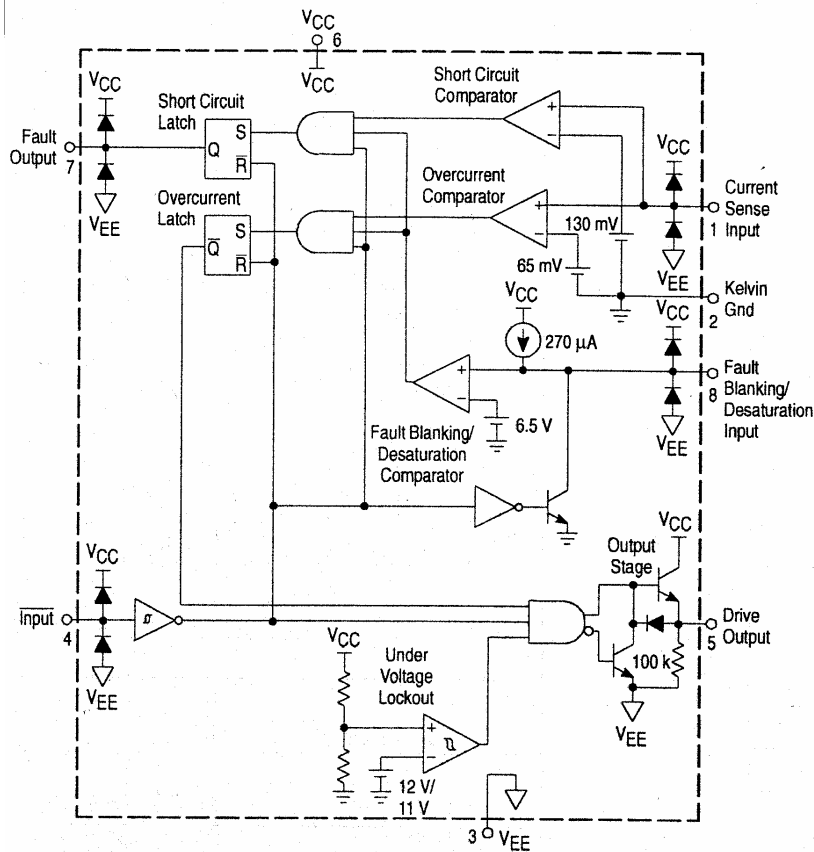

IL33153

ABSOLUTE MAXIMUM RATINGS

Rating	Symbol	Value	Unit
Power Supply Voltage V_{CC} to V_{EE}	$V_{CC}-V_{EE}$	20	V
Kelvin Ground to V_{EE} (Note 1)	KGnd - V_{EE}	20	
Logic Input	V_{in}	$V_{EE}-0,3$ to V_{CC}	V
Current Sense Input	V_S	-0.3 to V_{CC}	V
Blanking/Desaturation Input	V_{BD}	-0.3 to V_{CC}	V
Gate Drive Output Source Current Sink Current Diode Clamp Current	I_O	1.0 2.0 1.0	A
Fault Output Source Current Sink Current	I_{FO}	25 10	mA
Power Dissipation and Thermal Characteristics D Suffix SO-8 Package, Case 751 Maximum Power Dissipation @ $T_A = 50^{\circ}\text{C}$ Thermal Resistance, Junction-to-Air	P_D $R_{\theta JA}$	0.56 180	W $^{\circ}\text{C}/\text{W}$
P Suffix DIP-8 Package, Case 626 Maximum Power Dissipation @ $T_A = 50^{\circ}\text{C}$ Thermal Resistance, Junction-to-Air	P_D $R_{\theta JA}$	1.0 100	W $^{\circ}\text{C}/\text{W}$
Operating Junction Temperature	T_J	+150	$^{\circ}\text{C}$
Operating Ambient Temperature	T_A	-40 to +105	$^{\circ}\text{C}$
Storage Temperature Range	T_{stg}	-65 to +150	$^{\circ}\text{C}$

IL33153

ELECTRICAL CHARACTERISTICS ($V_{CC}=15V$, $V_{EE}=0V$, Kelvin Gnd connected to V_{EE} . For typical values $T_A=25^\circ C$, for min/max values T_A is the operating ambient temperature range that applies (Note 2), unless otherwise noted.)

Characteristic	Symbol	Min	Typ	Max	Unit
LOGIC INPUT					
Input Threshold Voltage]					V
High State (Logic 1)	V_{IH}	-	2.70	3.2	
Low State (Logic 0)	V_{IL}	1.2	2.30	-	
Input Current					μA
High State ($V_{IH} = 3.0 V$)	I_{IH}	-	130	500	
Low State ($V_{II} = 1.2 V$)	I_{IL}	-	50	100	
DRIVE OUTPUT					
Output Voltage					V
Low State ($I_{sink} = 1.0 A$)	V_{OL}	-	2.0	2.5	
High State ($I_{source} = 500 mA$)	V_{OH}	12	13.9	-	
Output Pull-Down Resistor	R_{PD}	-	100	200	$k\Omega$
FAULT OUTPUT					
Output voltage					V
Low State ($I_{sink} = 5.0 mA$)	V_{FL}	-	0.2	1.0	
High State ($I_{source} = 20 mA$)	V_{FH}	12	13.3	-	
SWITCHING CHARACTERISTICS					
Propagation Delay (50% Input to 50% Output $C_L = 1.0 nF$)					ns
Logic Input to Drive Output Rise	$t_{PLH}(in/out)$	-	80	300	
Logic Input to Drive Output Fall	$t_{PHL}(in/out)$	-	120	300	
Drive Output Rise Time (10% to 90%) $C_L = 1.0 nF$	t_r	-	17	55	ns
Drive Output Fall Time (90% to 10%) $C_L = 1.0 nF$	t_f	-	17	55	ns
Propagation Delay					μs
Current Sense Input to Drive Output	$t_{p(OC)}$	-	0.3	1.0	
Fault Blanking/Desaturation Input to Drive Output	$t_{p(FLT)}$	-	0.3	1.0	
UVLO					
Startup Voltage	$V_{SS\ start}$	11.3	12	12.6	V
Disable Voltage	$V_{SS\ dis}$	10.4	11	11.7	V
COMPARATORS					
Overcurrent Threshold Voltage ($V_{pin8} > 7.0 V$)	V_{SOC}	50	65	80	mV
Short Circuit Threshold Voltage ($V_{pin6} > 7.0 V$)	V_{SSC}	100	130	160	mV
Fault Blanking/Desaturation Threshold ($V_{pin1} > 100 mV$)	$V_{th(FLT)}$	6.0	6.5	7.0	V
Current Sense Input Current ($V_{si} = 0 V$)	I_{SI}	-	-1.4	-10	mA
FAULT BLANKING/DESATURATION INPUT					
Current Source ($V_{pin8} = 0 V$, $V_{pin4} = 0 V$)	I_{chg}	-200	-270	-300	mA
Discharge Current ($V_{pin8} = 15 V$, $V_{pin4} = 5.0 V$)	I_{dschg}	1.0	2.5	-	mA
TOTAL DEVICE					
Power Supply Current	I_{CC}				mA
Standby ($V_{pin4} = V_{CC}$, output Open)		-	7.2	14	
Operating ($C_L = 1.0 nF$, $f = 20 kHz$)		-	7.9	20	

- NOTES:** 1. Kelvin Ground must always be between V_{EE} and V_{CC} .
 2. Low duty cycle pulse techniques are used during test to maintain the junction temperature as close to ambient as possible.
 $T_{low} = -40^\circ C$ for IL33153
 $T_{high} = +105^\circ C$ for IL33153