

HEXFET[®] POWER MOSFET

IRFN340 N-CHANNEL

400 Volt, 0.55Ω HEXFET

HEXFET technology is the key to International Rectifier's advanced line of power MOSFET transistors. The efficient geometry achieves very low on-state resistance combined with high transconductance.

HEXFET transistors also feature all of the well-established advantages of MOSFETs, such as voltage control, very fast switching, ease of paralleling and electrical parameter temperature stability. They are well-suited for applications such as switching power supplies, motor controls, inverters, choppers, audio amplifiers, and high energy pulse circuits.

The Surface Mount Device (SMD-1) package represents another step in the continual evolution of surface mount technology. The SMD-1 will give designers the extra flexibility they need to increase circuit board density. International Rectifier has engineered the SMD-1 package to meet the specific needs of the power market by increasing the size of the termination pads, thereby enhancing thermal and electrical performance.

Product Summary

| Part Number | BV _{DSS} | R _{DS(on)} | I _D |
|-------------|-------------------|---------------------|----------------|
| IRFN340 | 400V | 0.55Ω | 10A |

Features:

- Avalanche Energy Rating
- Dynamic dv/dt Rating
- Simple Drive Requirements
- Ease of Paralleling
- Hermetically Sealed
- Surface Mount
- Light-weight

Absolute Maximum Ratings

| | Parameter | IRFN340 | Units |
|--|--------------------------------------|---------------|-------|
| I _D @ V _{GS} = 10V, T _C = 25°C | Continuous Drain Current | 10 | A |
| I _D @ V _{GS} = 10V, T _C = 100°C | Continuous Drain Current | 6 | |
| I _{DM} | Pulsed Drain Current ① | 40 | |
| P _D @ T _C = 25°C | Max. Power Dissipation | 125 | W |
| | Linear Derating Factor | 1.0 | W/K ⑤ |
| V _{GS} | Gate-to-Source Voltage | ±20 | V |
| EAS | Single Pulse Avalanche Energy ② | 650 | mJ |
| I _{AR} | Avalanche Current ① | 10 | A |
| E _{AR} | Repetitive Avalanche Energy ① | 12.5 | mJ |
| dv/dt | Peak Diode Recovery dv/dt ③ | 4.0 | V/ns |
| T _J | Operating Junction | -55 to 150 | °C |
| T _{STG} | Storage Temperature Range | | |
| | Package Mounting Surface Temperature | | |
| | Weight | 2.6 (typical) | g |

IRFN340 Device

Electrical Characteristics @ T_j = 25°C (Unless Otherwise Specified)

| | Parameter | Min. | Typ. | Max. | Units | Test Conditions |
|-------------------------------------|--|------|------|------|-------|---|
| BV _{DSS} | Drain-to-Source Breakdown Voltage | 400 | — | — | V | V _{GS} = 0V, I _D = 1.0mA |
| ΔBV _{DSS} /ΔT _J | Temperature Coefficient of Breakdown Voltage | — | 0.46 | — | V/°C | Reference to 25°C, I _D = 1.0mA |
| RDS(on) | Static Drain-to-Source | — | — | 0.55 | Ω | V _{GS} = 10V, I _D = 6A ④ |
| | On-State Resistance | — | — | 0.70 | | V _{GS} = 10V, I _D = 10A |
| VGS(th) | Gate Threshold Voltage | 2.0 | — | 4.0 | V | V _{DS} = V _{GS} , I _D = 250μA |
| gfs | Forward Transconductance | 4.9 | — | — | S (r) | V _{DS} > 15V, I _{DS} = 6A ④ |
| IDSS | Zero Gate Voltage Drain Current | — | — | 25 | μA | V _{DS} = 0.8 x Max Rating, V _{GS} = 0V |
| | | — | — | 250 | | V _{DS} = 0.8 x Max Rating V _{GS} = 0V, T _J = 125°C |
| IGSS | Gate-to-Source Leakage Forward | — | — | 100 | nA | V _{GS} = 20V |
| IGSS | Gate-to-Source Leakage Reverse | — | — | -100 | nA | V _{GS} = -20V |
| Qg | Total Gate Charge | 32 | — | 65 | nC | V _{GS} = 10V, I _D = 10A |
| Qgs | Gate-to-Source Charge | 2.2 | — | 10.0 | | V _{DS} = Max. Rating x 0.5 |
| Qgd | Gate-to-Drain ("Miller") Charge | 13.8 | — | 40.5 | | see figures 6 and 13 |
| td(on) | Turn-On Delay Time | — | — | 2.5 | ns | V _{DD} = 200V, I _D = 10A, R _G = 9.1Ω, V _{GS} = 10V |
| tr | Rise Time | — | — | 92 | | |
| td(off) | Turn-Off Delay Time | — | — | 79 | | |
| tf | Fall Time | — | — | 58 | | |
| LD | Internal Drain Inductance | — | 2.0 | — | nH | Measured from the drain lead, 6mm (0.25 in.) from package to center of die. |
| LS | Internal Source Inductance | — | 6.5 | — | | Measured from the source lead, 6mm (0.25 in.) from package to source bonding pad. |
| Ciss | Input Capacitance | — | 1400 | — | pF | V _{GS} = 0V, V _{DS} = 25V f = 1.0 MHz see figure 5 |
| Coss | Output Capacitance | — | 3500 | — | | |
| Crss | Reverse Transfer Capacitance | — | 2300 | — | | |

Source-Drain Diode Ratings and Characteristics

| | Parameter | Min. | Typ. | Max. | Units | Test Conditions |
|-----------------|--|--|------|------|-------|---|
| I _S | Continuous Source Current (Body Diode) | — | — | 10 | A | Modified MOSFET symbol showing the integral reverse p-n junction rectifier. |
| I _{SM} | Pulse Source Current (Body Diode) ① | — | — | 40 | | |
| V _{SD} | Diode Forward Voltage | — | — | 1.5 | V | T _J = 25°C, I _S = 10A, V _{GS} = 0V ④ |
| t _{rr} | Reverse Recovery Time | — | — | 600 | ns | T _J = 25°C, I _F = 10A, di/dt ≤ 100A/μs V _{DD} ≤ 50V ④ |
| Q _{RR} | Reverse Recovery Charge | — | — | 5.6 | μC | |
| t _{on} | Forward Turn-On Time | Intrinsic turn-on time is negligible. Turn-on speed is substantially controlled by L _S + L _D . | | | | |

Thermal Resistance

| | Parameter | Min. | Typ. | Max. | Units | Test Conditions |
|----------------------|----------------------|------|------|------|-------|------------------------------------|
| R _{thJC} | Junction-to-Case | — | — | 1.0 | K/W | Soldered to a copper clad PC board |
| R _{thJ-PCB} | Junction-to-PC Board | — | TBD | — | | |

IRFN340 Device

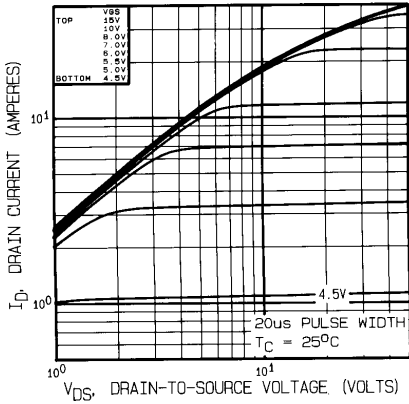

Fig. 1 — Typical Output Characteristics
 $T_c = 25^\circ\text{C}$

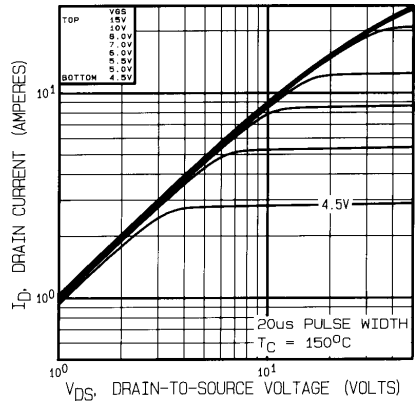

Fig. 2 — Typical Output Characteristics
 $T_c = 150^\circ\text{C}$

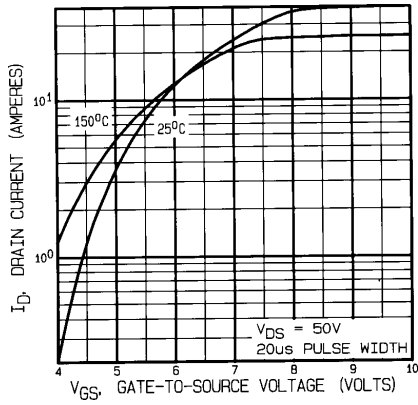

Fig. 3 — Typical Transfer Characteristics

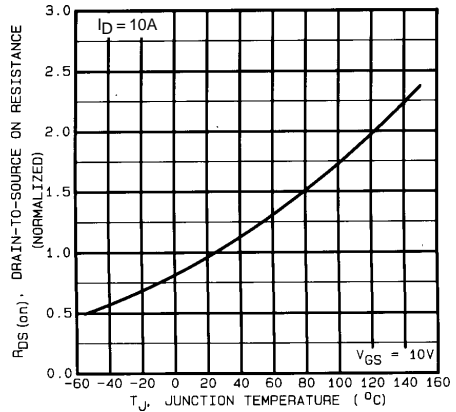

Fig. 4 — Normalized On-Resistance Vs. Temperature

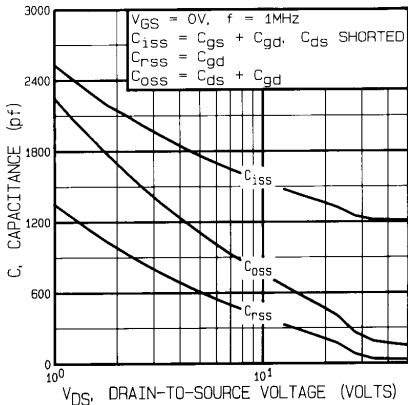

Fig. 5 — Typical Capacitance Vs. Drain-to-Source Voltage

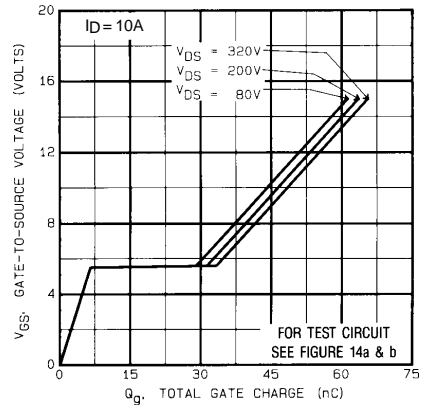

Fig. 6 — Typical Gate Charge Vs. Gate-to-Source Voltage

IRFN340 Device

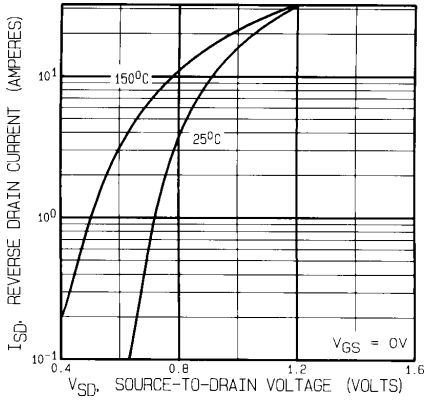

Fig. 7 — Typical Source-to-Drain Diode Forward Voltage

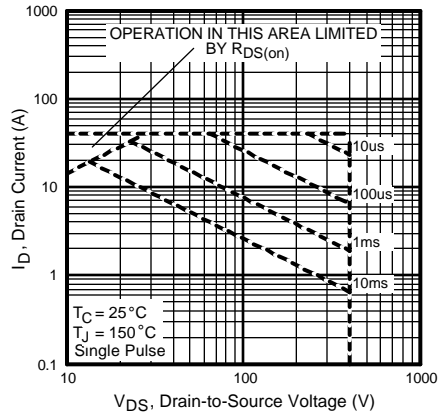

Fig. 8 — Maximum Safe Operating Area

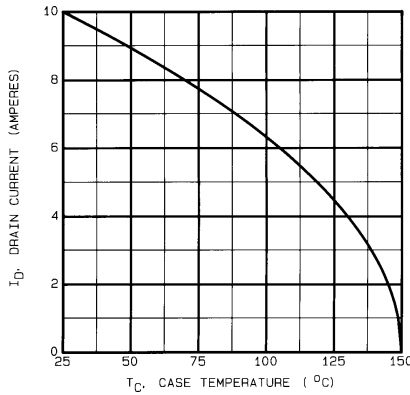

Fig. 9 — Maximum Drain Current Vs. Case Temperature

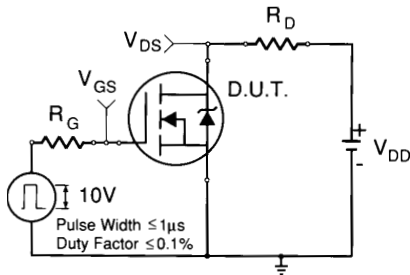

Fig. 10a — Switching Time Test Circuit

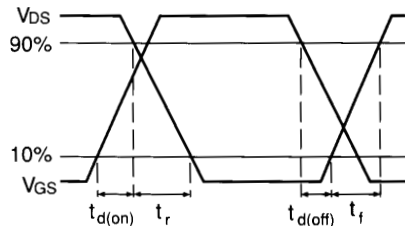

Fig. 10b — Switching Time Waveforms

IRFN340 Device

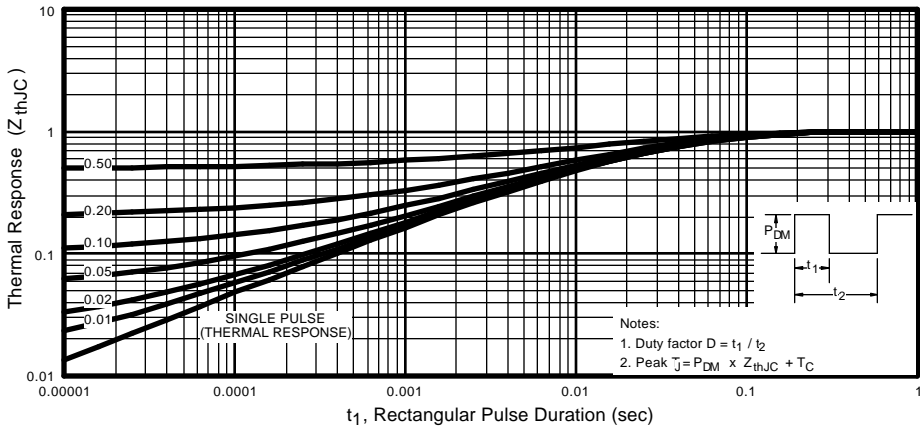

Fig. 11 — Maximum Effective Transient Thermal Impedance, Junction-to-Case Vs. Pulse Duration

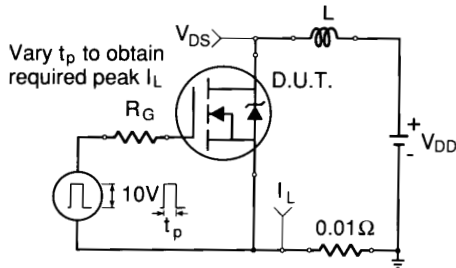

Fig. 12a — Unclamped Inductive Test Circuit

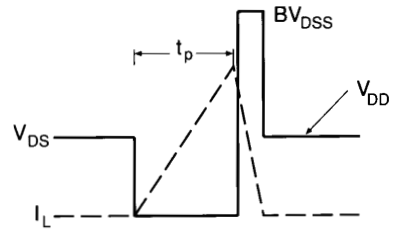

Fig. 12b — Unclamped Inductive Waveforms

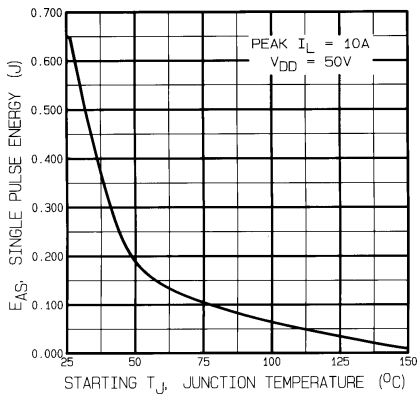

Fig. 12c — Max. Avalanche Energy vs. Current

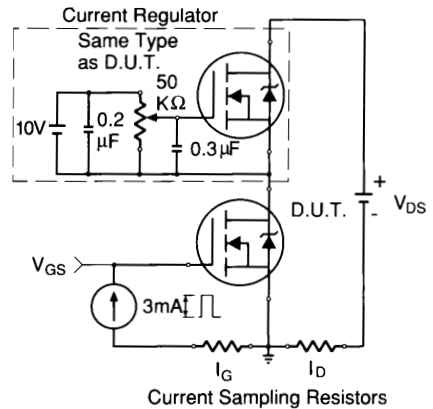

Fig. 13a — Gate Charge Test Circuit

IRFN340 Device

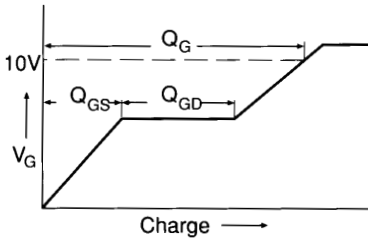
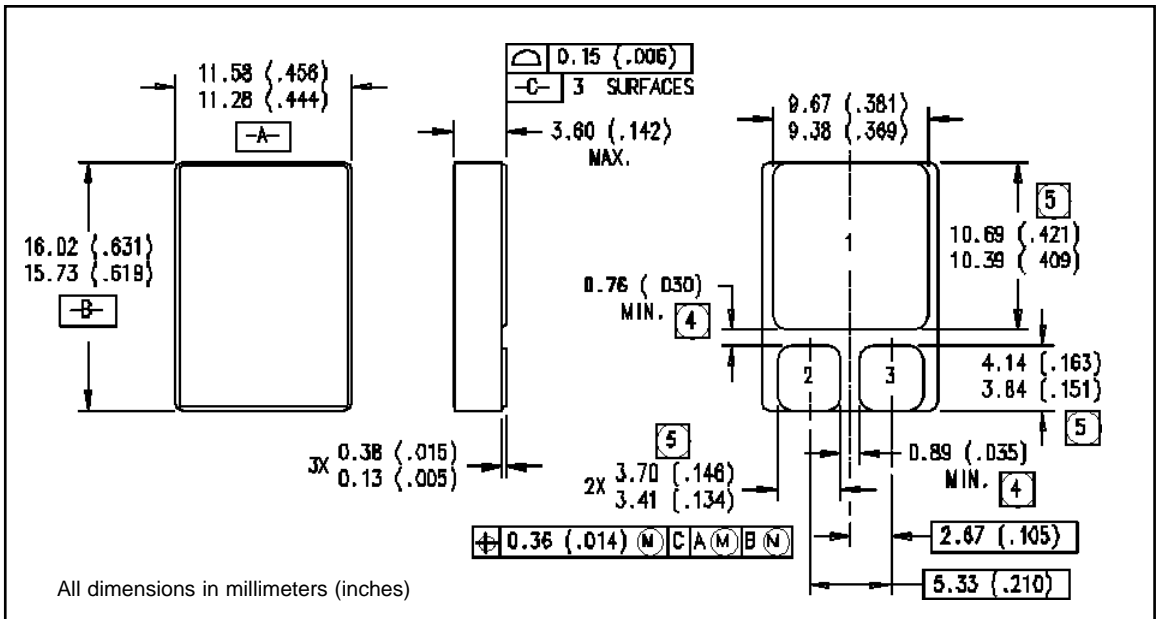

Fig. 13b — Basic Gate Charge Waveform

- ① Repetitive Rating; Pulse width limited by maximum junction temperature. (see figure 11)
- ② @ $V_{DD} = 50V$, Starting $T_J = 25^\circ C$,
 $EAS = [0.5 * L * (I_L^2) * [BV_{DSS}/(BV_{DSS} - V_{DD})]$
 Peak $I_L = 10A$, $V_{GS} = 10V$, $25 \leq R_G \leq 200\Omega$
- ③ $I_{SD} \leq 10A$, $di/dt \leq 120A/\mu s$,
 $V_{DD} \leq BV_{DSS}$, $T_J \leq 150^\circ C$
- ④ Pulse width $\leq 300 \mu s$; Duty Cycle $\leq 2\%$
- ⑤ $K/W = ^\circ C/W$
 $W/K = W/^\circ C$

Case Outline and Dimensions — SMD-1



International
IR Rectifier

WORLD HEADQUARTERS: 233 Kansas St., El Segundo, California 90245, Tel: (310) 322 3331

EUROPEAN HEADQUARTERS: Hurst Green, Oxted, Surrey RH8 9BB, UK Tel: ++ 44 1883 732020

IR CANADA: 7321 Victoria Park Ave., Suite 201, Markham, Ontario L3R 2Z8, Tel: (905) 475 1897

IR GERMANY: Saalburgstrasse 157, 61350 Bad Homburg Tel: ++ 49 6172 96590

IR ITALY: Via Liguria 49, 10071 Borgaro, Torino Tel: ++ 39 11 451 0111

IR FAR EAST: K&H Bldg., 2F, 3-30-4 Nishi-Ikeburo 3-Chome, Toshima-Ki, Tokyo Japan 171 Tel: 81 3 3983 0086

IR SOUTHEAST ASIA: 315 Outram Road, #10-02 Tan Boon Liat Building, Singapore 0316 Tel: 65 221 8371

<http://www.irf.com/> Data and specifications subject to change without notice. 9/96