

KSM-91 TM1E

The KSM-91 TM1E consist of a PIN Photodiode of high speed and a preamplifier IC in the package as an receiver for Infrared remote control systems

Features

- Wide angle design
- Wide supply-voltage range : 2.7V to 5.5V
- Shielded against electrical field disturbance
- High immunity against ambient light disturbances (Logic Controller Adaptation)
- Available for carrier frequencies between 32.7KHz to 56.9KHz
- TTL and CMOS compatible

Applications

- Audio & Video Applications (TV, VTR, Audio, DVDP, CDP)
- Home Appliances (Air conditioner, Computer, Camcorder)
- Wireless Toys
- Remote Control Equipment

DIMENSIONS

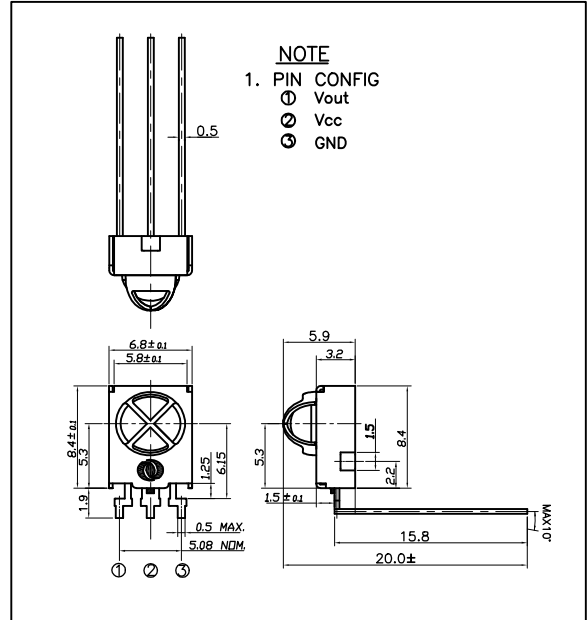

Maximum Ratings

[Ta=25]

Parameter	Symbol	Ratings	Unit
Supply Voltage	Vcc	6.0	V
Operating Temperature	Topr	-10 ~ +60	
Storage Temperature	Tstg	-20 ~ +75	
Soldering Temperature	Tsol	260 (Max 5 sec)	

B.P.F Center Frequency

Model No.	B.P.F Center Frequency(kHz)
KSM-911TM1E	40.0
KSM-912TM1E	36.7
KSM-913TM1E	37.9
KSM-914TM1E	32.7
KSM-915TM1E	56.9

Electro-Optical Characteristics

[Ta=25 , Vcc=5.0V(Vcc=3.0V)]

Parameter	Symbol	Condition	Min.	Typ.	Max.	Unit	
Recommended Supply Voltage	Vcc		2.7	-	5.5	V	
Current Consumption	Icc	No signal input	0.5	1.2(1.0)	1.7	mA	
Peak Wavelength *1	λ		-	940	-	nm	
B.P.F Center Frequency	f _o		-	37.9	-	kHz	
Transmission Distance *1	L	250 ± 50lx	0 °	15	-	-	m
			± 30 °	12	-	-	
High level Output voltage *1	V _{OH}	30cm over the ray axis	4.5(2.8)	5.0(3.0)	-	V	
Low level Output voltage *1	V _{OL}		-	0.1	0.5	V	
High level Output Pulse Width *1	T _{WH}	Burst wave=600μs	500	600	700	μs	
Low level Output Pulse Width *1	T _{WL}	Period = 1.2ms	500	600	700	μs	
Output Form	Active Low Output						

*1. It specifies the maximum distance between emitter and detector that the output wave form satisfies the standard under the conditions below against the standard transmitter.

- 1) Measuring place : Indoor without extreme reflection of light
- 2) Ambient light source : Detecting surface illumination shall be irradiate 200 ± 50lx under ordinary white fluorescence lamp without high frequency lightning
- 3) Standard transmitter : Burst wave of standard transmitter shall be arranged to 50mVP-P under the measuring circuit

KSM-91 □ TM1E

■ Measuring Method [Ta=25°C]

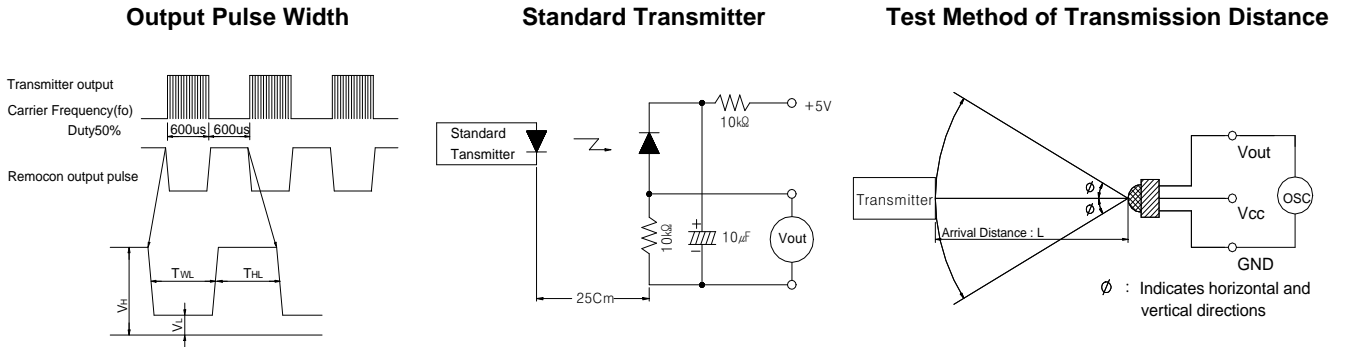

■ Typical Characteristics Curve [Ta=25°C]

Relative reception distance Vs. Supply voltage

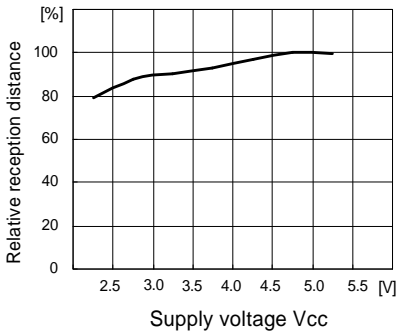

Relative reception distance Vs. Ambient temperature

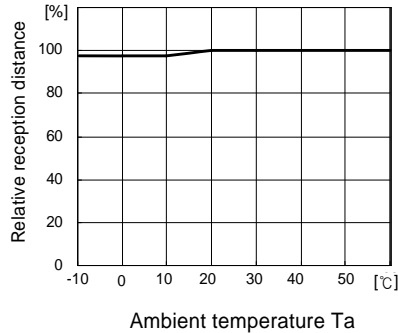

Radiant pattern

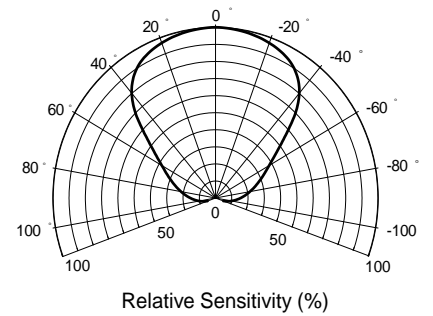

■ Standard Application Circuit with R-C Decoupling Filter

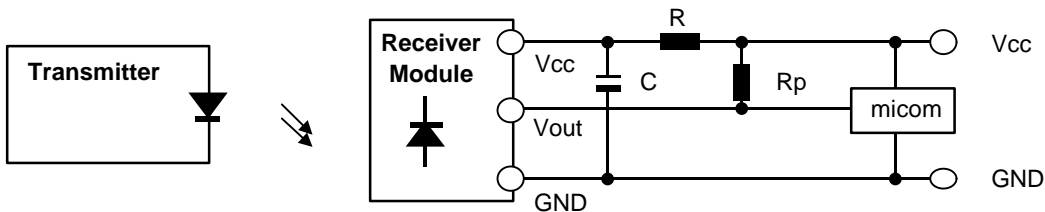

*1 Recommended Circuit Description

- 1) Transmitter(IRED) drive current
: $I_{FP} = 300\text{mA}_{P-P} \sim 600\text{mA}_{P-P}$
- 2) R-C Decoupling Filter with Lower Cut-off Frequency
: $R=100\Omega$, $C=47\mu F \Rightarrow f_c = 1/2\pi RC = 33.9\text{Hz}$
- 3) External pull-up resistor(optional)
: $10k\Omega$ over