

TOSHIBA Photo Transistor Silicon NPN Epitaxial Planar

TPS601A(F)

Lead Free Product
 Photoelectric Counter
 Position Detection
 Various Kinds Of Readers

- TO-18 metal CAN package
- High sensitivity.
- Sharp directivity. Incident light can be effectively used.
 : $\theta_{1/2} = \pm 10^\circ$ (typ.)
- The same size TPS604(F) with the base pin is available.

Maximum Ratings (Ta = 25°C)

Characteristic	Symbol	Rating	Unit
Collector-emitter voltage	V_{CEO}	40	V
Emitter-collector voltage	V_{ECO}	5	V
Collector current	I_C	50	mA
Collector power dissipation	P_C	150	mW
Collector power dissipation derating (Ta > 25°C)	$\Delta P_C / ^\circ C$	-1.2	mW / °C
Operating temperature range	T_{opr}	-40~125	°C
Storage temperature range	T_{stg}	-55~150	°C

Unit in mm

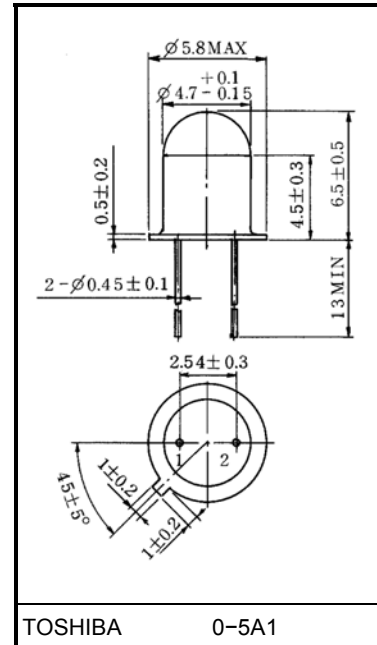

Weight: 0.39 g (typ.)

Pin Connection

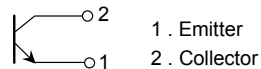

Opto-Electrical Characteristics (Ta = 25°C)

Characteristic		Symbol	Test Condition	Min	Typ.	Max	Unit	
Dark current		$I_D (I_{CEO})$	$V_{CE} = 30V, E = 0$	—	0.01	0.2	μA	
Light current		I_L	$V_{CE} = 3V$ $E = 0.1mW / cm^2$ (Note)	TPS601A (F)	100	—	—	μA
				TPS601A (A,F)	100	—	300	
				TPS601A (B,F)	200	—	600	
				TPS601A (C,F)	400	—	1200	
Collector-emitter saturation voltage		$V_{CE (sat)}$	$I_C = 30 \mu A, E = 0.1mW / cm^2$ (Note)	—	0.25	0.4	V	
Switching time	rise time	t_r	$V_{CC} = 5V, I_C = 10mA$ $R_L = 100\Omega$	—	2	—	μs	
	fall time	t_f		—	2	—		
Peak sensitivity wavelength		λ_P		—	800	—	nm	
Half value angle		$\theta \frac{1}{2}$		—	± 10	—	°	

Note: Color temperature = 2870K, standard tungsten lamp.

Precaution

Please be careful of the followings.

1. Soldering temperature: 260°C max.

Soldering time: 5s max.

(Soldering portion of lead: Above 1.5mm from the body of the device.)

2. If the lead is formed, the lead should be formed at a distance of 2mm from the body of the device.

Soldering shall be performed after lead forming.

Product Indication

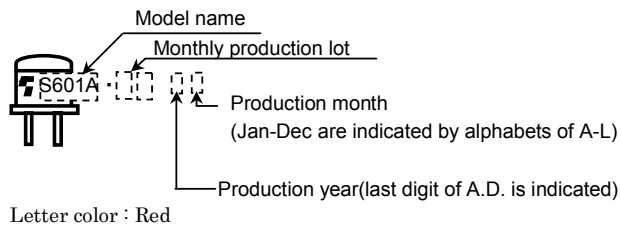
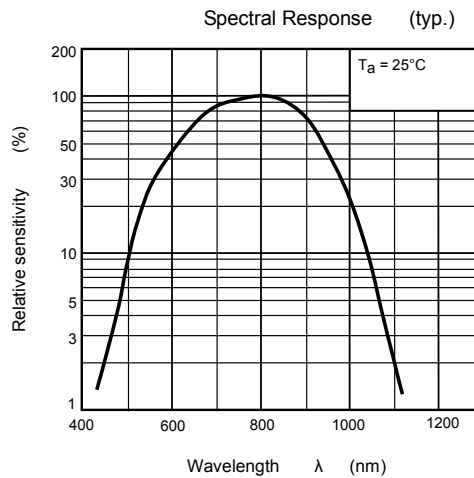
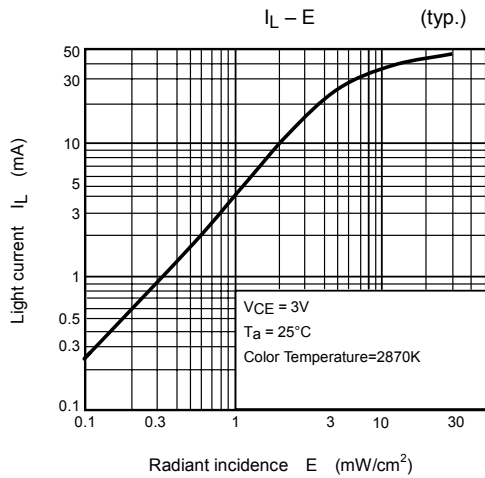
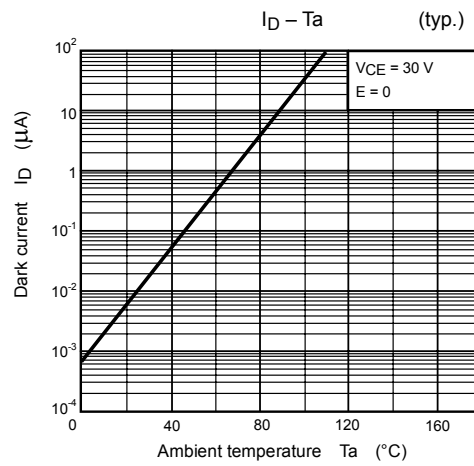
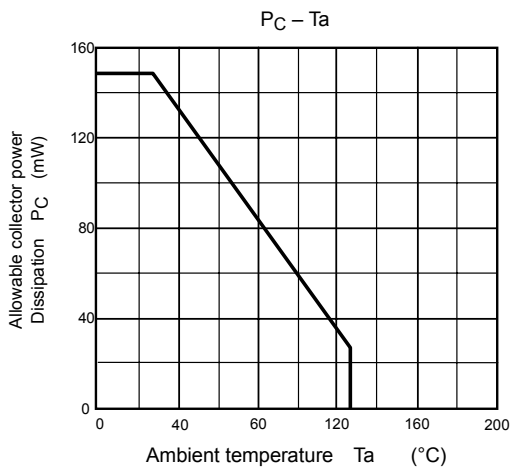
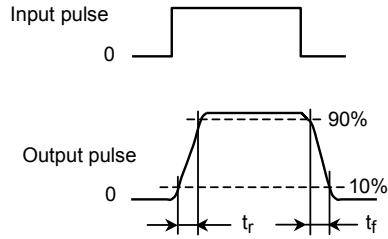
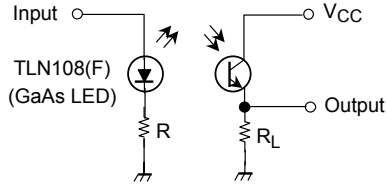
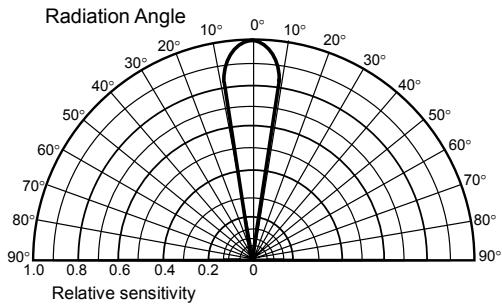

Fig.1 Switching time test circuit



Directional Sensitivity Characteristic (typ.)

(Ta = 25°C)



Frequency Characteristics (typ.)

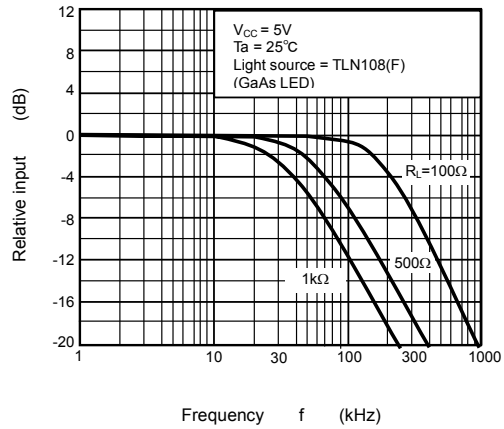

Switching Characteristics (typ.)

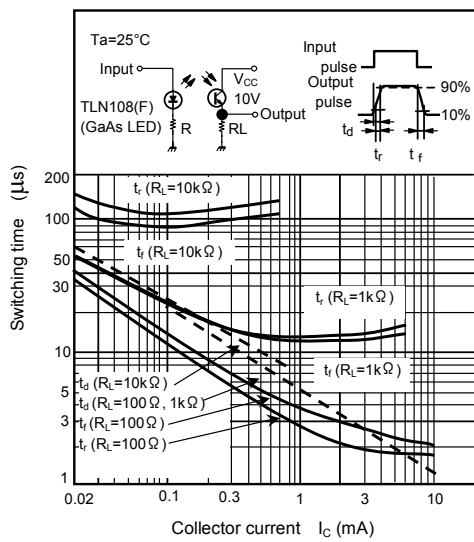

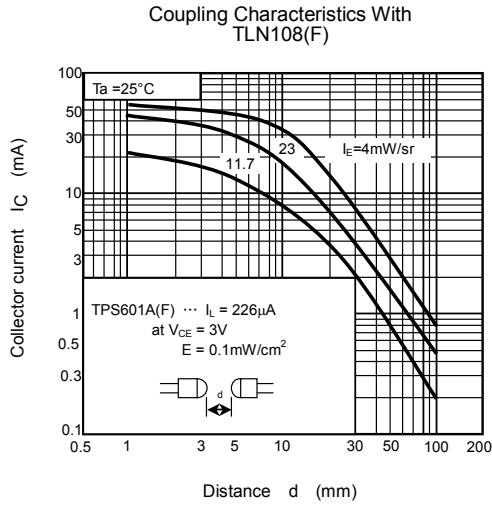
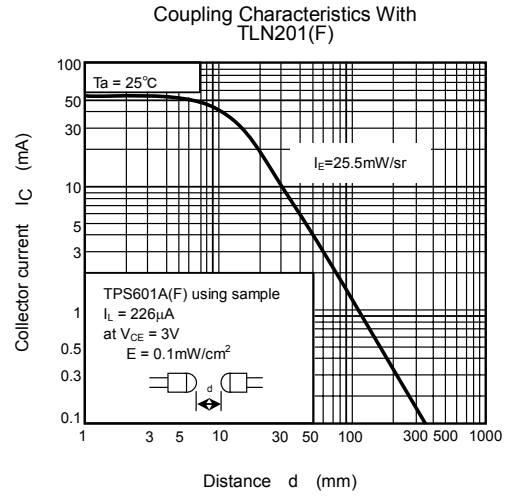
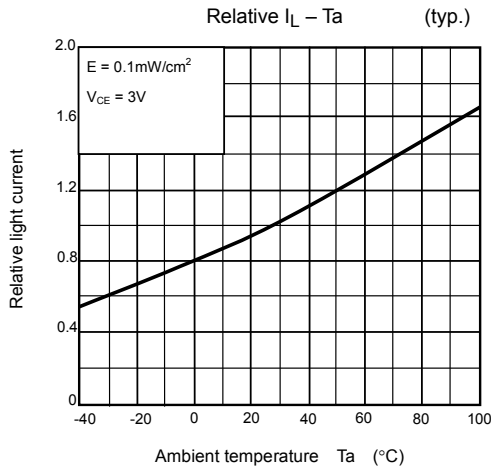

RESTRICTIONS ON PRODUCT USE

030619EBA

- The information contained herein is subject to change without notice.
- The information contained herein is presented only as a guide for the applications of our products. No responsibility is assumed by TOSHIBA for any infringements of patents or other rights of the third parties which may result from its use. No license is granted by implication or otherwise under any patent or patent rights of TOSHIBA or others.
- TOSHIBA is continually working to improve the quality and reliability of its products. Nevertheless, semiconductor devices in general can malfunction or fail due to their inherent electrical sensitivity and vulnerability to physical stress. It is the responsibility of the buyer, when utilizing TOSHIBA products, to comply with the standards of safety in making a safe design for the entire system, and to avoid situations in which a malfunction or failure of such TOSHIBA products could cause loss of human life, bodily injury or damage to property.
In developing your designs, please ensure that TOSHIBA products are used within specified operating ranges as set forth in the most recent TOSHIBA products specifications. Also, please keep in mind the precautions and conditions set forth in the "Handling Guide for Semiconductor Devices," or "TOSHIBA Semiconductor Reliability Handbook" etc..
- The TOSHIBA products listed in this document are intended for usage in general electronics applications (computer, personal equipment, office equipment, measuring equipment, industrial robotics, domestic appliances, etc.). These TOSHIBA products are neither intended nor warranted for usage in equipment that requires extraordinarily high quality and/or reliability or a malfunction or failure of which may cause loss of human life or bodily injury ("Unintended Usage"). Unintended Usage include atomic energy control instruments, airplane or spaceship instruments, transportation instruments, traffic signal instruments, combustion control instruments, medical instruments, all types of safety devices, etc.. Unintended Usage of TOSHIBA products listed in this document shall be made at the customer's own risk.
- The products described in this document are subject to the foreign exchange and foreign trade laws.
- TOSHIBA products should not be embedded to the downstream products which are prohibited to be produced and sold, under any law and regulations.