



TS2411

Tong Ringer

SOP-8



DIP-8

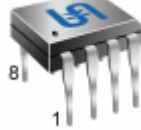

Pin assignment:
1. Vcc 5. Gnd
2. Rsl 6. Hfo
3. Lfi 7. Hfi
4. Lfo 8. Out

Operating Voltage 13 to 36V
Ringling Start Voltage 36V (max.)

General Description

The TS2411 is a bipolar integrated circuit designed for telephone bell replacement.

Features

- ◇ Designed for Telephone Bell Replacement
- ◇ Low Current Drain
- ◇ Adjustable 2-frequency Tone
- ◇ Adjustable Warbling Rate
- ◇ Extension Tone Ringer Modules
- ◇ Alarms or Other Alerting Devices
- ◇ Adjustable for Reduced Supply Initiation Current.
- ◇ Built-in hysteresis prevents false triggering and rotary dial 'Chirps'

Ordering Information

Part No.	Operating Temp.	Package
TS2411CD	-20 ~ +70 °C	DIP-8
TS2411CS		SOP-8

Block Diagram

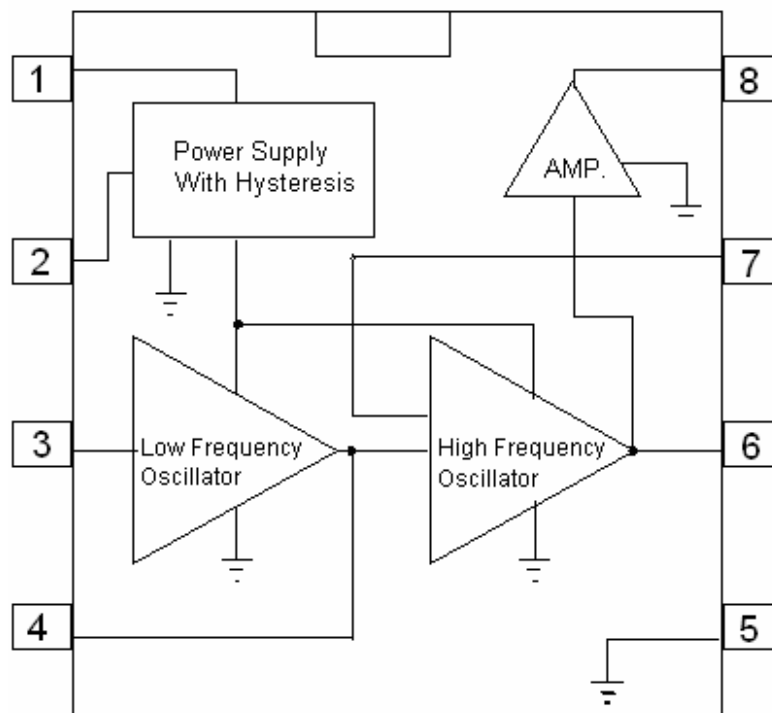



Absolute Maximum Rating			
Description	Symbol	Value	Unit
DC Supply Voltage (Referenced to GND)	VCC	+ 36	V
Power Dissipation in Still Air Plastic DIP	PD	400	mW
Switch Collector Voltage	Tstg	-65 to +150	°C

Note: * Maximum Ratings are those values beyond which damage to the device may occur. Functional operation should be restricted to the Recommended Operating Conditions.

Recommended Operating Conditions				
Description	Symbol	Min	Max	Unit
Operating Voltage	Vopr	13	36	V
Operating Temperature	T _A	-45	+65	°C

Note: This device contains protection circuitry to guard against damage due to high static voltages or electric fields. However, precautions must be taken to avoid applications of any voltage higher than maximum rated voltages to this high-impedance circuit. For proper operation, V_{IN} and V_{OUT} should be constrained to the range

$$GND \leq (V_{IN} \text{ or } V_{OUT}) \leq V_{CC}$$

Unused inputs must always be tied to an appropriate logic voltage level (e.g., either GND or Vcc). Unused outputs must be left open.

Electrical Characteristics (Voltages Referenced to GND, T_A = -20 to +70 °C)

Parameter	Symbol	Test Conditions	Min	Typ	Max	Unit
Initiation Supply Voltage (1)	V _{SI}	See Figure 2	16.8	--	21.2	V
Initiation Supply Current (1)	I _{SI}	See Figure 2	1.4	--	4.2	mA
Sustaining Voltage (1)	V _{SUS}	See Figure 2	9.5	--	12.2	V
Sustaining Current	I _{SUS}	See Figure 2	0.7	--	2.5	mA
High-Level Output Voltage	V _{OH}	V _{CC} =21V, I _{OH} =-15mA, Pin6=6V, Pin7=GND	16.7	--	21.0	V
Low-Level Output Voltage	V _{OL}	V _{CC} =21V, I _{OL} =15mA, Pin6= GND, Pin7=6V	--	--	1.8	V
Maximun Input Leakage Current	I _{IN}	Pin3 =6V, Pin4 =GND, V _{CC} =21V	--	--	1.0	μA
		Pin7 =6V, Pin6 =GND, V _{CC} =21V	--	--	1.0	μA
High Frequency 1	F _{H1}	R ₃ =191KΩ, C ₃ =6800pF	461	--	563	H _Z
High Frequency 2	F _{H2}	R ₃ =191KΩ, C ₃ =6800pF	576	--	704	H _Z
Low Frequency	F _L	R ₂ =165KΩ, C ₂ =0.47uF	9.0	--	11.0	H _Z
Ringing Start Voltage (4)	V _{tr}	See Figure 1	--	--	36	V

- Notes :**
1. Initiation supply voltage (V_{SI}) is the supply voltage required to start the tone ringer oscillating.
 2. Sustaining voltage (V_{SUS}) is the supply voltage required to maintain oscillation.
 3. Ringing start voltage is the value of AC supply voltage required to start the tone ringer ringing in FIG.3
 4. This product is not designed for protection against radioactive rays.
 5. All data and specifications are subject to change without notice.

Application Circuit

. HOW TO USE THE RSL PIN

In the IC, the supply initiation current (I_{si}) can be changed using the RSL Pin. As show is the diagram, the RSL (Pin 2) is grounded through resistor R_s . By changing the R_s value, supply initiation current can be changed.

Supply voltage (V_{cc}) vs. supply current (I_{cc}) characteristics resulting from changes in the value of R_s are shown in the following diagram.

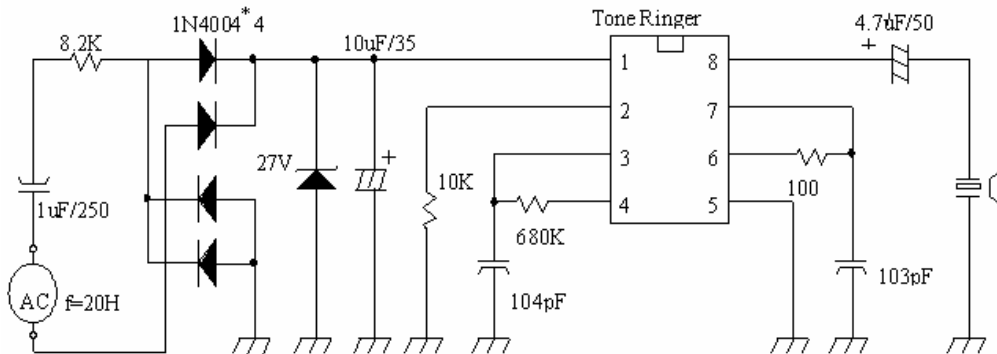
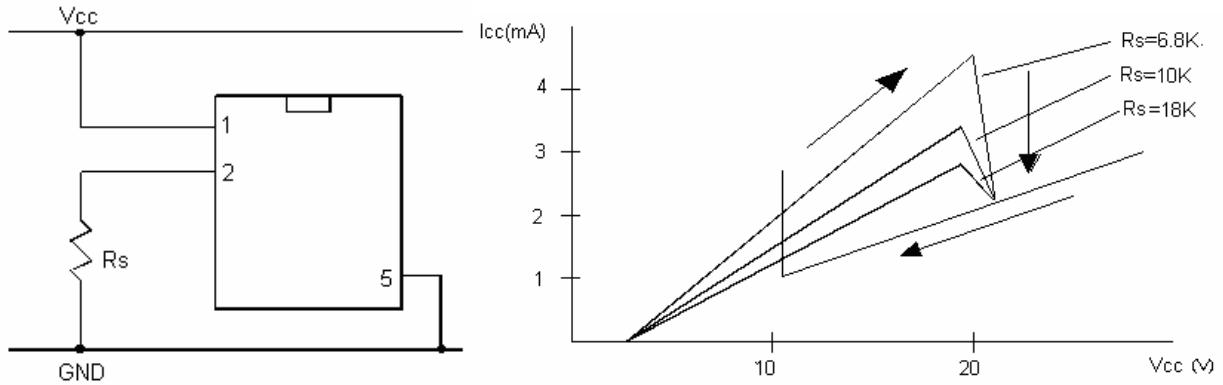

Figure 1. Ringing Start Voltage Test Circuit

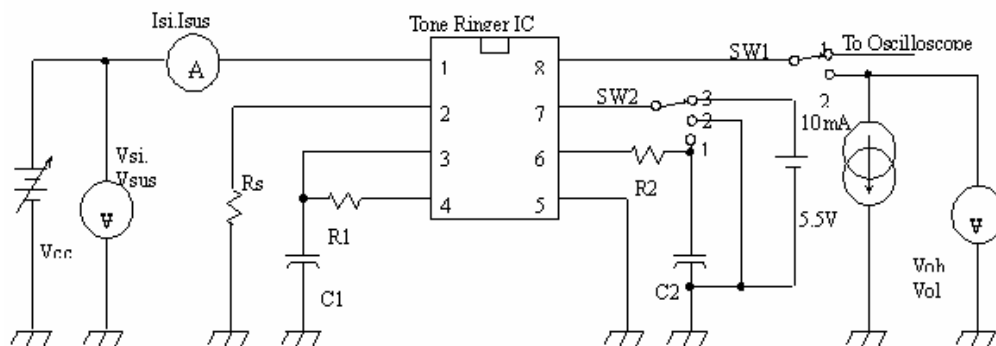

Figure 2. Test Circuit (1)

Application Circuit

SWITCH POSITION IS THE FOLLOWING TABLE :

PARAMETER	SW1	SW2
V _{si} , I _{si}	1	1
V _{sus} , I _{sus}	1	1
V _{oh}	2	2
V _{ol}	2	3

R1 = 165 K (+/-) 1%
 R2 = 191 K (+/-) 1%
 C1 = 0.47 μF (+/-) 5%
 C2 = 0.0068 μF (+/-) 5%

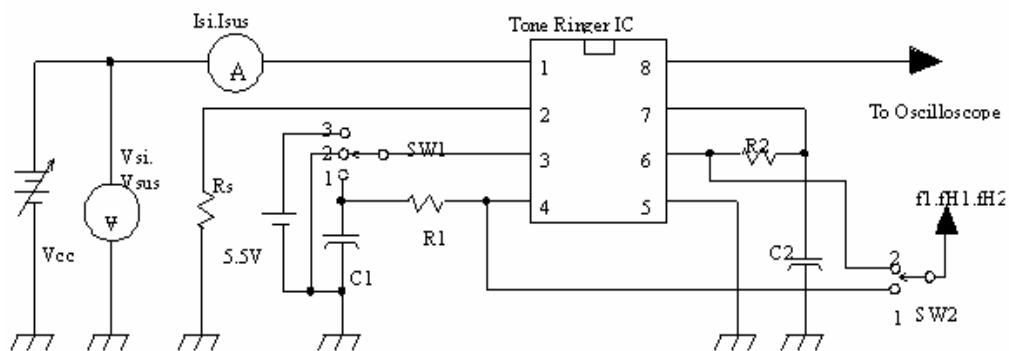

Figure 3. Test Circuit (2)

SWITCH POSITION IS THE FOLLOWING TABLE :

PARAMETER	SW1	SW2
FL	1	1
fH1	3	2
fH2	2	2

R1 = 165 K (+/-) 1%
 R2 = 191 K (+/-) 1%
 C1 = 0.47 μF (+/-) 5%
 C2 = 0.0068 μF (+/-) 5%

Application Note

The application circuit illustrates the use of the TS2411 devices in typical telephone or extension tone ringer application.

The AC ringer signal voltage appears across the TIP and RING inputs of the circuit and is attenuated by capacitor C1 and resistor R1.

C1 also provides isolation from DC voltages (48V) on the exchange line.

After full wave rectification by the bridge diode, the waveform is filtered by capacitor C4 to provide a DC supply for the tone ringer chip. As this voltage exceeds the initiation voltage (VSI), oscillation starts.

With the components shown, the output frequency chops between 512(fH1) and 640Hz(fH2) at a 10Hz(fL) rate.

The loudspeaker load is coupled through a 1300W to 8W transformer.

The output coupling capacitor C5 is required with transformer coupled loads.

When driving a piezo-ceramic transducer type load, the coupling C5 and transformer (1300W:8W) are not required. However, a current limiting resistor is required.

The low frequency oscillator oscillates at a rate (fL) controlled by an external resistor (R2) and capacitor (C2).

The frequency can be determined using the relation $fL = 1/1.289R2 * C2$. The high frequency oscillates at a fH1, fH2 controlled by an external resistor (R3) and capacitor (C3). The frequency can be determined using the relation $fH1 = 1/1.504R3 * C3$, $fH2 = 1/1.203R3 * C3$.

Application Note

Pin 2 allows connection of an external resistor RSL, which is used to program the slope of the supply current vs supply voltage characteristics (see Fig2), and hence the supply current up to the initiation voltage (VSI). This initiation voltage remains constant independent of RSL.

The supply current drawn prior to triggering varies inversely with RSL, decreasing for increasing value of resistance. Thus, increasing the value of RSL will decrease the amount of AC ringing current required to trigger the device. As such, longer subscriber loops are possible since less voltage is dropped per unit length of loop wire due to the lower current level. RSL can also be used to compensated for smaller AC couplin capacitors (C5 on Fig 3) (higher impedance) to the line which can be used to alter the ringer equivalence number of a tone ringer circuit.

The graph in Fig2 illustrates the variation of supply current with supply voltage. Three curves are drawn to show the variation of initiation current with RSL. Curve B(RSL=6.8KW) shows the I-V characteristic for the TS2411 tone ringer.

Curve A is a plot with $R_{SL} < 6.8KW$ and shows an increase in the current drawn up to the initiation voltage VSI. The I-V characteristic after initiation remains unchanged. Curve C illustrates the effect of increasing RSL above 6.8KW initiation current decreases but again current after triggering is unchanged.

Characteristics Curve

CIRCUIT CURRENT-SUPPLY VOLTAGE (NO LOAD)

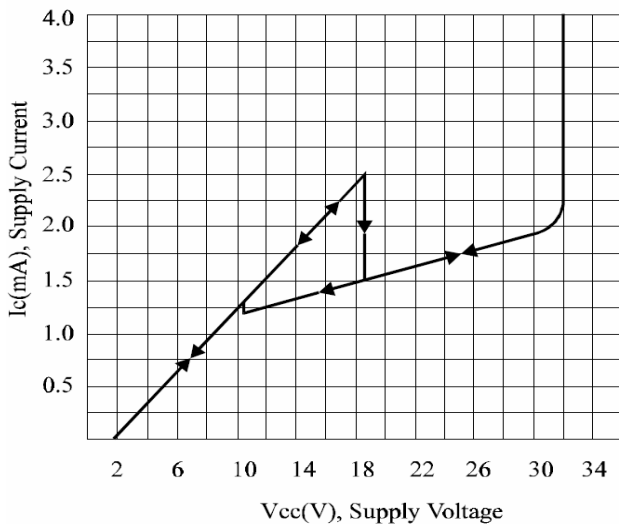

Figure 4.

SUPPLY CURRENT (NO LOAD) VC. SUPPLY VOLTAGE

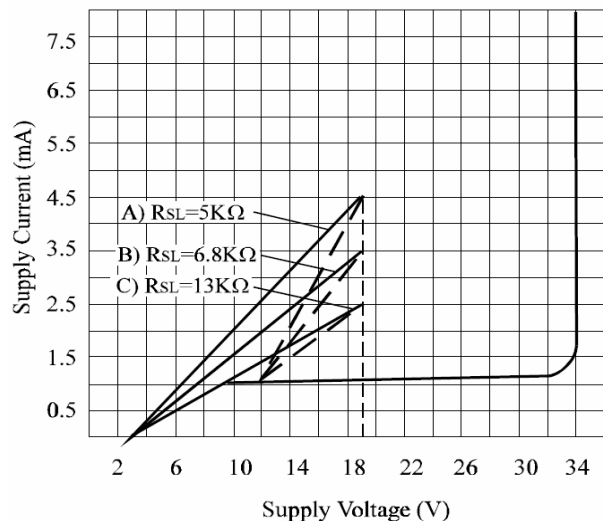
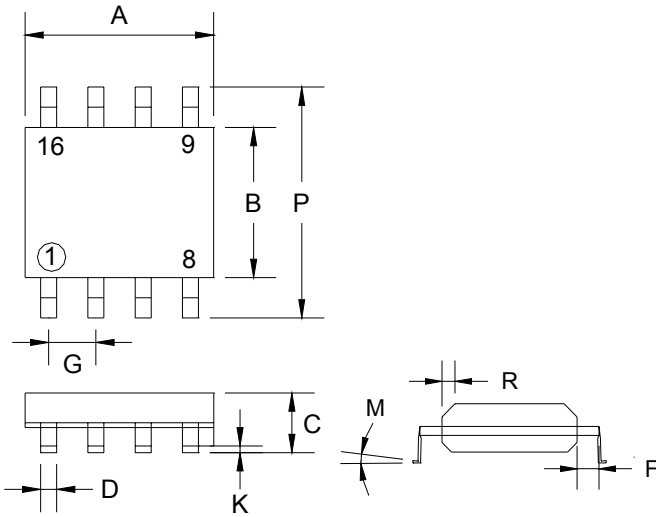

Figure 5.

SOP-8 Mechanical Drawing



SOP-8 DIMENSION				
DIM	MILLIMETERS		INCHES	
	MIN	MAX	MIN	MAX
A	4.80	5.00	0.189	0.196
B	3.80	4.00	0.150	0.157
C	1.35	1.75	0.054	0.068
D	0.35	0.49	0.014	0.019
F	0.40	1.25	0.016	0.049
G	1.27 (typ)		0.05 (typ)	
K	0.10	0.25	0.004	0.009
M	0°	7°	0°	7°
P	5.80	6.20	0.229	0.244
R	0.25	0.50	0.010	0.019

DIP-8 Mechanical Drawing

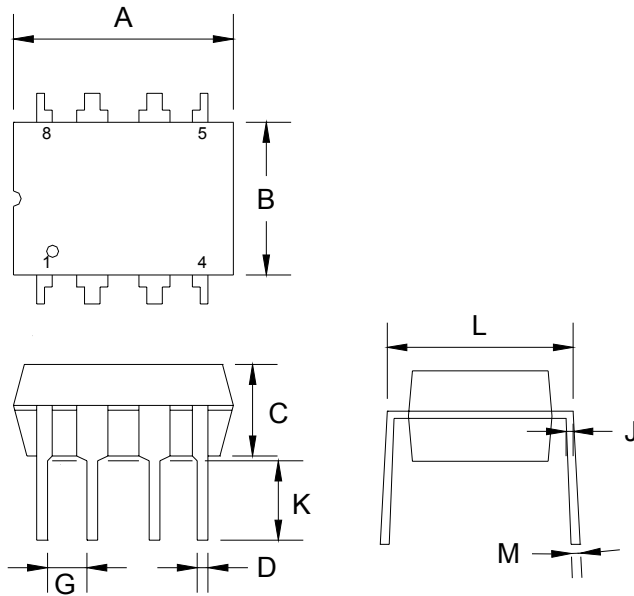

DIP-8 DIMENSION				
DIM	MILLIMETERS		INCHES	
	MIN	MAX	MIN	MAX
A	9.07	9.32	0.357	0.367
B	6.22	6.48	0.245	0.255
C	3.18	4.45	0.125	0.135
D	0.35	0.55	0.019	0.020
G	2.54 (typ)		0.10 (typ)	
J	0.29	0.31	0.011	0.012
K	3.25	3.35	0.128	0.132
L	7.75	8.00	0.305	0.315
M	-	10°	-	10°