



## 4-BIT MICROCONTROLLER

### **Table of Contents-**

1.	GENERAL DESCRIPTION .....	2
2.	FEATURES .....	2
3.	BLOCK DIAGRAM .....	4
4.	PIN CONFIGURATION .....	5
5.	PIN DESCRIPTION.....	6
6.	ELECTRICAL CHARACTERISTICS.....	7
6.1	Absolute Maximum Ratings .....	7
6.2	DC Characteristics .....	7
6.3	AC Characteristics.....	8
7.	APPLICATION CIRCUIT.....	9
8.	REVISION HISTORY .....	10

## 1. GENERAL DESCRIPTION

The W541L250 is fully compatible with W741L250 in the terms of pin assignment and IC function except main oscillator. It is a high-performance 4-bit microcontroller ( $\mu\text{C}$ ) that provides an LCD driver. The device contains a 4-bit ALU, two 8-bit timers, a divider, a  $24 \times 4$  LCD driver, and five 4-bit I/O ports (including 1 output port for LED driving). There are also five interrupt sources and 8-level subroutine nesting for interrupt applications. The W541L250 operates on low voltage and very low current and has two power reduction modes, hold mode and stop mode, which help to minimize power dissipation.

The W541L250 is suitable for remote controllers, watches and clocks, multiple I/O products, keyboard controllers, speech synthesis LSI controllers, and other products.

## 2. FEATURES

- Operating voltage: 1.2 ~ 1.8V (LCD drive voltage: 3.0V, or 4.5V)
- Single system clock
  - Oscillation frequency up to 1 MHz, Crystal or RC oscillator is selected by mask code option,
  - High-frequency (400 KHz to 1 MHz) or low-frequency (32.768 KHz) oscillation is selected by mask code option
- Memory
  - $2048 \times 16$  bit program ROM (including  $2K \times 4$  bit look-up table)
  - $128 \times 4$  bit data RAM (including 16 working registers)
  - $24 \times 4$  LCD data RAM
- 21 input/output pins
  - Ports for input only: 2 ports/8 pins
  - Input/output ports: 2 ports/8 pins
  - Port for output only: 1 port /4 pins (high sink current to drive LEDs)
  - MFP output pin: 1 pin (MFP)
  - Do not be floating when it is as input or output open-drain (NMOS type).
- Power-down mode
  - Hold function: no operation (except for oscillator)
  - Stop function: no operation (including main clock)
- Five types of interrupts
  - Three internal interrupts (Divider 0, Timer 0, Timer 1)
  - Two external interrupt (Port RC and  $\overline{\text{INT}}$  pin)



- LCD driver output
  - 24 segment × 4 common
  - Static, 1/2 duty (1/2 bias), 1/3 duty (1/2 or 1/3 bias), 1/4 duty (1/3 bias) driving mode can be selected
  - LCD driver output pins can be used as DC output ports; selectable by code option
- MFP output pin
  - Output is software selectable as modulating or nonmodulating frequency
  - Works as frequency output specified by Timer 1
- Built-in 14-bit clock frequency divider circuit
- Two built-in 8-bit programmable countdown timers
  - Timer 0: one of two internal clock frequencies ( $F_{OSC}/4$  or  $F_{OSC}/1024$ ) can be selected
  - Timer 1: includes an auto-reload function; and one of two internal clock frequencies ( $F_{OSC}$  or  $F_{OSC}/64$ ) can be selected or falling edge of pin RC.0 can be selected (output through MFP pin)
- Built-in 18/14-bit watchdog timer selectable for system reset
- Powerful instruction set: 119 instructions
- 8-level subroutine (include interrupt) nesting
- Up to 4  $\mu$ S instruction cycle (with 1 MHz operating frequency)
- Packaged in 64-pin QFP

3. BLOCK DIAGRAM

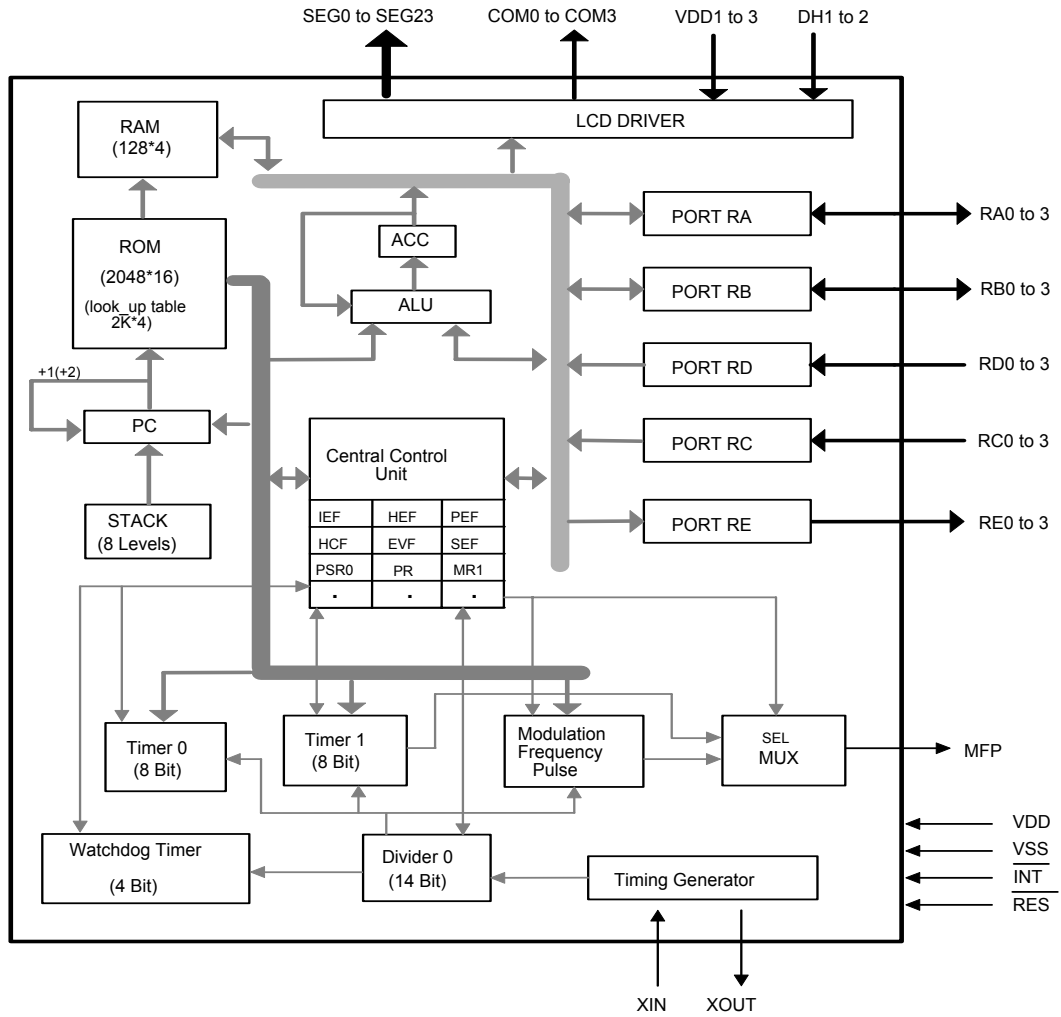



4. PIN CONFIGURATION

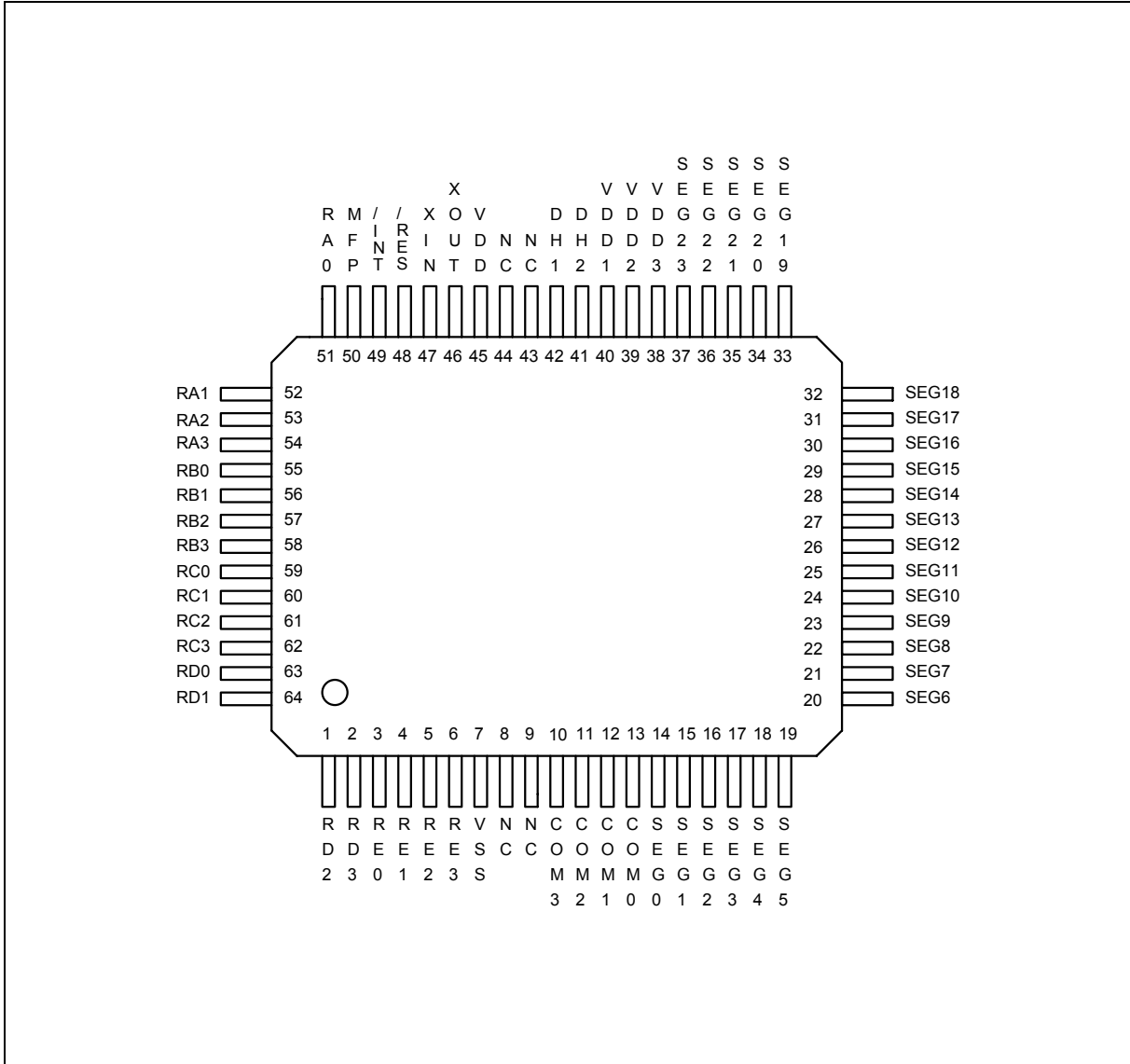



## 5. PIN DESCRIPTION

SYMBOL	I/O	FUNCTION																									
XIN	I	Input pin for oscillator. Connected to crystal or resistor to generate system clock by code option. External 10~20pF capacitor uses to get accurate freq in crystal mode.																									
XOUT	O	Output pin for oscillator. Connected to crystal or resistor to generate system clock by code option. 20PF capacitor is built in internal for crystal mode.																									
RA0–RA3	I/O	Input/Output port. Input/output mode specified by port mode 1 register (PM1).																									
RB0–RB3	I/O	Input/Output port. Input/output mode specified by port mode 2 register (PM2).																									
RC0–RC3	I	4-bit port for input only. Each pin has an independent interrupt capability. And build-in schmitt trigger.																									
RD0–RD3	I	4-bit port for input only.																									
RE0–RE3	O	Output port only. This port provides high sink current to drive LEDs.																									
MFP	O	Output pin only. This pin can output modulating or nonmodulating frequency, or Timer 1 clock output specified by mode register 1 (MR1).																									
$\overline{\text{INT}}$	I	External interrupt pin with pull-high resistor.																									
$\overline{\text{RES}}$	I	System reset pin with pull-high resistor.																									
SEG0–SEG23	O	LCD segment output pins. Can also be used as DC output ports specified by code option.																									
COM0–COM3	O	LCD common signal output pins. <table border="1" style="margin-left: 20px;"> <thead> <tr> <th></th> <th>Static</th> <th>1/2 Duty</th> <th>1/3 Duty</th> <th>1/4 Duty</th> </tr> </thead> <tbody> <tr> <td>COM0</td> <td>Used</td> <td>Used</td> <td>Used</td> <td>Used</td> </tr> <tr> <td>COM1</td> <td>Not Used</td> <td>Used</td> <td>Used</td> <td>Used</td> </tr> <tr> <td>COM2</td> <td>Not Used</td> <td>Not Used</td> <td>Used</td> <td>Used</td> </tr> <tr> <td>COM3</td> <td>Not Used</td> <td>Not Used</td> <td>Not Used</td> <td>Used</td> </tr> </tbody> </table> <p>The LCD alternating frequency can be selected by code option.</p>		Static	1/2 Duty	1/3 Duty	1/4 Duty	COM0	Used	Used	Used	Used	COM1	Not Used	Used	Used	Used	COM2	Not Used	Not Used	Used	Used	COM3	Not Used	Not Used	Not Used	Used
	Static	1/2 Duty	1/3 Duty	1/4 Duty																							
COM0	Used	Used	Used	Used																							
COM1	Not Used	Used	Used	Used																							
COM2	Not Used	Not Used	Used	Used																							
COM3	Not Used	Not Used	Not Used	Used																							
DH1, DH2	I	Connection terminals for voltage doubler (halver) capacitor.																									
VDD1, VDD2 VDD3	I	Positive (+) supply voltage terminal. Refer to Functional Description.																									
VDD	I	Positive power supply (+).																									
VSS	I	Negative power supply (-).																									



## 6. ELECTRICAL CHARACTERISTICS

### 6.1 Absolute Maximum Ratings

PARAMETER	RATING	UNIT
Supply Voltage to Ground Potential	-0.3 to +7.0	V
Applied Input/Output Voltage	-0.3 to +7.0	V
Power Dissipation	120	mW
Ambient Operating Temperature	0 to +70	°C
Storage Temperature	-55 to +150	°C

Note: Exposure to conditions beyond those listed under Absolute Maximum Ratings may adversely affect the life and reliability of the device.

### 6.2 DC Characteristics

( $V_{DD}-V_{SS} = 1.5V$ ,  $F_{osc} = 32.768$  KHz,  $T_A = 25^\circ C$ ; unless otherwise specified)

PARAMETER	SYM.	CONDITIONS	MIN.	TYP.	MAX.	UNIT
Op. Volt (Crystal type)	VDD1	High-frequency Oscillation	1.35	-	1.8	V
Op. Voltage (RC type)	VDD2	High-frequency Oscillation	1.2	-	1.8	V
Op. Volt (RC, Crystal)	VDD3	Low-frequency Oscillation	1.2	-	1.8	V
Op. Current (Crystal type)	IOP1	No load (Ext-V)	-	4	12	$\mu A$
Op. Current (RC type)	IOP2	No load (Ext-V)	-	35	65	$\mu A$
Hold Current (Crystal type)	IHM1	Hold mode No load (Ext-V)	-	3	6	$\mu A$
Hold Current (RC type)	IHM2	Hold mode No load (Ext-V)	-	16	40	$\mu A$
Stop Current (Crystal type)	ISM1	Stop mode No load (Ext-V)	-	0.1	2	$\mu A$
Stop Current (RC type)	ISM2	Stop mode No load (Ext-V)	-	0.1	2	$\mu A$
Input Low Voltage	VIL	-	VSS	-	0.3 VDD	V
Input High Voltage	VIH	-	0.7 VDD	-	VDD	V
MFP Output Low Voltage	VML	IOL = 0.9mA	-	-	0.3	V
MFP Output High Voltage	VMH	IOH = -0.75mA	1.2	-	-	V
Port RA, RB Output Low Voltage	VABL	IOL = 1.0mA	-	0.2	0.3	V



DC Characteristics, continued

PARAMETER	SYM.	CONDITIONS	MIN.	TYP.	MAX.	UNIT
Port RA, RB Output High Voltage	VABH	IOH = -0.5mA	1.2	1.4	-	V
LCD Supply Current	ILCD	All Seg. On	-	-	3	μA
SEG0–SEG23 Sink Current (work as LCD output pins)	IOL	VOL = 0.05V VLCD = 0.0V	6	-	-	μA
SEG0–SEG23 Drive Current (work as LCD output pins)	IOH	VOH = 4.45V VLCD = 4.5V	1.5	-	-	μA
SEG0–SEG23 Output Low Voltage (work as DC output pins)	VSL	IOL = 150 μA	-	-	0.15	V
SEG0–SEG23 Output High Voltage (work as DC output pins)	*VSH	IOH = -1.0 μA	1.05	-	-	V
Port RE Sink Current	IEL	VOL = 0.3V	2	-	-	mA
Port RE Source Current	IEH	VOH = 1.2V	0.35	-	-	mA
Input Port Pull-up Resistor	RCD	Port RC, RD	400	1000	1500	KΩ
$\overline{\text{INT}}$ Pull-up Resistor	RINT	-	200	1000	1500	KΩ
$\overline{\text{RES}}$ Pull-up Resistor	RRES	-	200	500	1500	KΩ

Note : \*VSH:Its ability is based on LCD power connected to 0.1 uF capacitor.

### 6.3 AC Characteristics

(VDD–VSS = 1.5V, TA = 25° C; unless otherwise specified)

PARAMETER	SYM.	CONDITIONS	MIN.	TYP.	MAX.	UNIT
Op. Frequency	FOSC	RC type	-	-	1000	KHz
		Crystal type (Option low-speed type only)	-	32.768	-	
Oscillator Start-up Time	TS	VDD = 1.2 V, FOSC = 32.768 KHz	-	1	2	S
Instruction Cycle Time	TI	One machine cycle	-	4/FOSC	-	mS
Reset Active Width	TRAW	FOSC = 32.768 KHz	1	-	-	μS
Interrupt Active Width	TIAW	FOSC = 32.768 KHz	1	-	-	μS



## 7. APPLICATION CIRCUIT

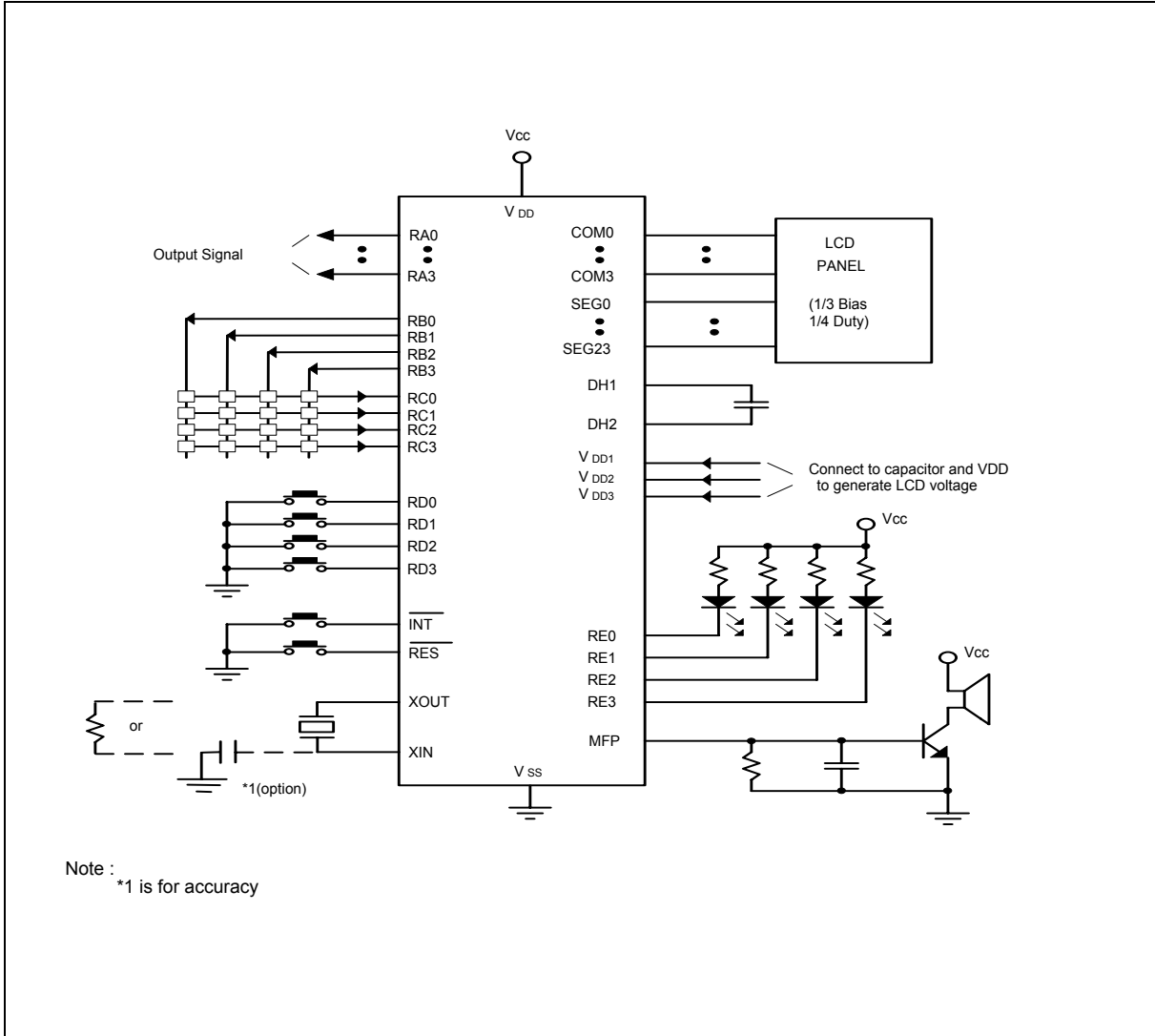



## 8. REVISION HISTORY

VERSION	DATE	DESCRIPTION
A2	-	Note: Xin/Xout had been built-in 20 pF capacitor. Delete XOUT capacitor from application circuit
A3	-	Note: Recommend working voltage range for Hi freq X all mode ( L series)
A4	-	Note: RC is built-in schmitt trigger
A5	-	Note: Do not be floating when it is as input or output open-drain (NMOS type)
A6	May 29, 2003	Note : Update DC psec formate ( L250,L260)



### Headquarters

No. 4, Creation Rd. III,  
Science-Based Industrial Park,  
Hsinchu, Taiwan  
TEL: 886-3-5770066  
FAX: 886-3-5665577  
<http://www.winbond.com.tw/>

### Taipei Office

9F, No.480, Rueiguang Rd.,  
Neihu District, Taipei, 114,  
Taiwan, R.O.C.  
TEL: 886-2-8177-7168  
FAX: 886-2-8751-3579

### Winbond Electronics Corporation America

2727 North First Street, San Jose,  
CA 95134, U.S.A.  
TEL: 1-408-9436666  
FAX: 1-408-5441798

### Winbond Electronics Corporation Japan

7F Daini-ueno BLDG, 3-7-18  
Shinyokohama Kohoku-ku,  
Yokohama, 222-0033  
TEL: 81-45-4781881  
FAX: 81-45-4781800

### Winbond Electronics (Shanghai) Ltd.

27F, 2299 Yan An W. Rd. Shanghai,  
200336 China  
TEL: 86-21-62365999  
FAX: 86-21-62365998

### Winbond Electronics (H.K.) Ltd.

Unit 9-15, 22F, Millennium City,  
No. 378 Kwun Tong Rd.,  
Kowloon, Hong Kong  
TEL: 852-27513100  
FAX: 852-27552064

*Please note that all data and specifications are subject to change without notice.  
All the trade marks of products and companies mentioned in this data sheet belong to their respective owners.*