

► LIN transceiver with voltage regulator

E910.18 | E910.45

FEATURES

- ▶ Supply voltage range VS 5.25V to 18V
- ▶ LIN-Bus transceiver, up to 20kbaud
- ▶ Output driver with slewrates control
- ▶ Very low standby current (<30µA typical)
- ▶ Bus input voltage range from -24V to +30V (independent of VS)
- ▶ Wake up function via bus
- ▶ Regulator output voltage 5V, ±1.5%, 100mA, current limitation
- ▶ Reset with two reset times (15ms and 100ms) and two reset levels:
 E910.18: 3.15V and 4.65V
 E910.45: 3.15V and 3.95V
- ▶ Undervoltage recognition, fixed threshold at typ. 7.3V
- ▶ Over temperature protection
- ▶ Universal comparator with high voltage input
- ▶ -40°C to +125°C operating temperature
- ▶ SO16w package

APPLICATION

- ▶ Automotive bus systems
- ▶ Body electronics
- ▶ Comfort electronics

DESCRIPTION

The IC is designed for LIN slave applications. The microcontroller is completely protected from the harsh automotive environment.

For sensor applications only these two ICs are needed. Even the sensor supply can be done as a rule with the integrated 100mA VDD regulator.

The over temperature protection disables the voltage regulator and the bus driver. After return to normal operation conditions a reset function will be generated.

Two versions of this IC with different reset levels are available:
 E910.18: 3.15V / 4.65V and E910.45: 3.15V / 3.95V

PINNING

Pin	Name	Description
1	VS	Positive supply voltage
2	EN	Enable input for VDD
3	VTR	Reset time and threshold select
4	GND	Ground
5	GND	Ground
6	BUS	Send / receive pin
7	SI	Universal comparator input
8	SO	Universal comparator digital output
9	NC	Not connected
10	RxD	Serial data from IC to µC
11	TxD	Serial data from µC to IC
12	GND	Ground
13	TEST	For test only. Connect to GND
14	RESET	Reset output, active Low
15	SENSE	Input voltage monitor
16	VDD	Output 5V /100mA

PACKAGE

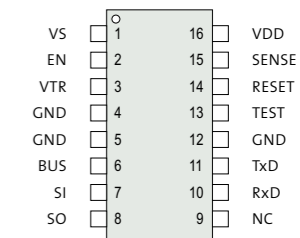

BLOCK DIAGRAM

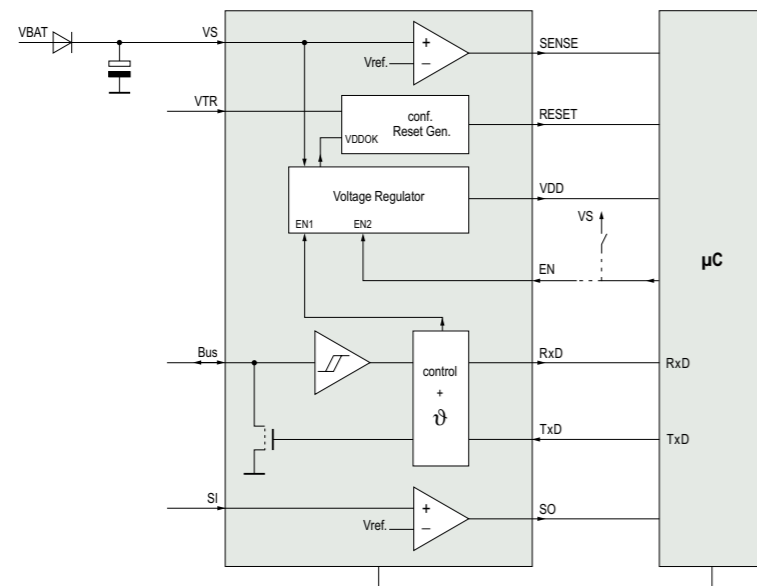

Note ELMOS Semiconductor AG (below ELMOS) reserves the right to make changes to the product contained in this publication without notice. ELMOS assumes no responsibility for the use of any circuits described herein, conveys no licence under any patent or other right, and makes no representation that the circuits are free of patent infringement. While the information in this publication has been checked, no responsibility, however, is assumed for inaccuracies. ELMOS does not recommend the use of any of its products in life support applications where the failure or malfunction of the product can reasonably be expected to cause failure of a life-support system or to significantly affect its safety or effectiveness. Products are not authorized for use in such applications.

Copyright © 2005 ELMOS Reproduction, in part or whole, without the prior written consent of ELMOS, is prohibited.

www.elmos.de | sales@elmos.de