

# Dual ,Low-Noise,150mA LDO Regulator

## DESCRIPTION

The EUP7201 is highly accurate, Dual, low noise, CMOS LDO voltage regulator. Performance features include low output noise, high ripple rejection ratio, low dropout and very fast turn-on times.

The EUP7201 is also fully compatible with low ESR ceramic capacitors, reducing cost and improving output stability. This high level of output stability is maintained even during frequent load fluctuations, due to the excellent transient response performance and high PSRR achieved across a broad range of frequencies.

The EN function allows the output of each regulator to be turned off independently, resulting in greatly reduced power consumption. The EUP7201 is available in the SOT23-6 , TDFN-6 and USP-6 package.

## FEATURES

- Up to 150mA Output Current (Each LDO)
- Dual Shutdown Pins Control Each Output
- 124  $\mu$  V<sub>RMS</sub> Low Noise Output
- Current Limiting and Thermal Protection
- Short Circuit Protection
- 100mV Dropout at 100mA Load
- Current Limiting Protection
- Available in SOT23-6 , TDFN-6 and USP-6 Package
- RoHS Compliant and 100% Lead (Pb)-Free

## APPLICATIONS

- Cellular Phones
- Camera, Video Recorders
- PDAs
- Hand-held Equipment

## Typical Application Circuit

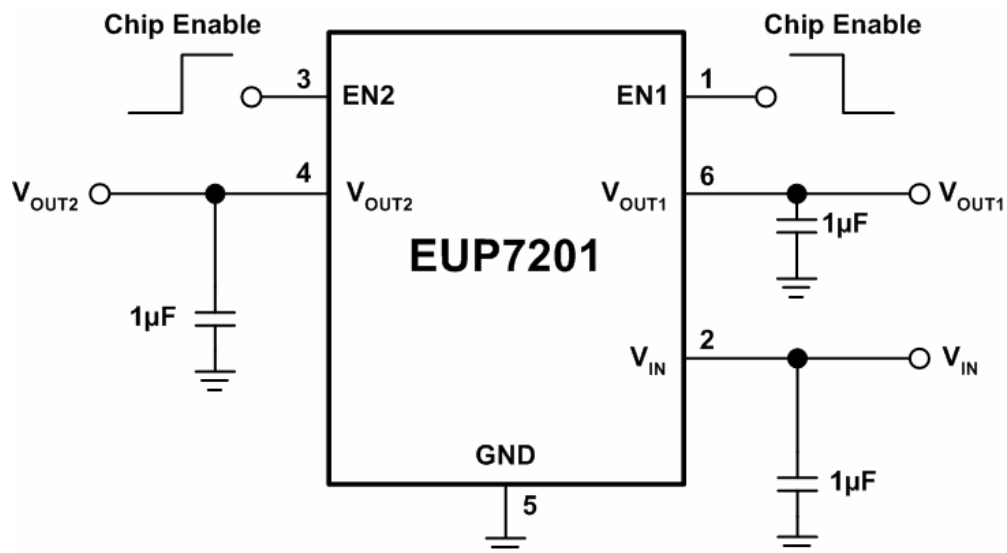

Figure 1.

**Pin Configurations**

Package Type	Pin Configurations	Package Type	Pin Configurations
SOT23-6		TDFN-6	
USP-6	<p style="text-align: center;"><b>Pin Configurations</b></p>		

**Pin Description**

PIN	SOT23-6	TDFN-6	USP-6	DESCRIPTION
EN1	1	3	3	ON/OFF Control $V_{OUT1}$
VIN	2	2	2	Supply Input
EN2	3	1	1	ON/OFF Control $V_{OUT2}$
$V_{OUT2}$	4	6	6	Channel 2 Output Voltage
GND	5	4	4	Ground
$V_{OUT1}$	6	5	5	Channel1 Output Voltage

Note: If EN1 and EN2 are both low, both regulators and the reference turn off.

## Block Diagram

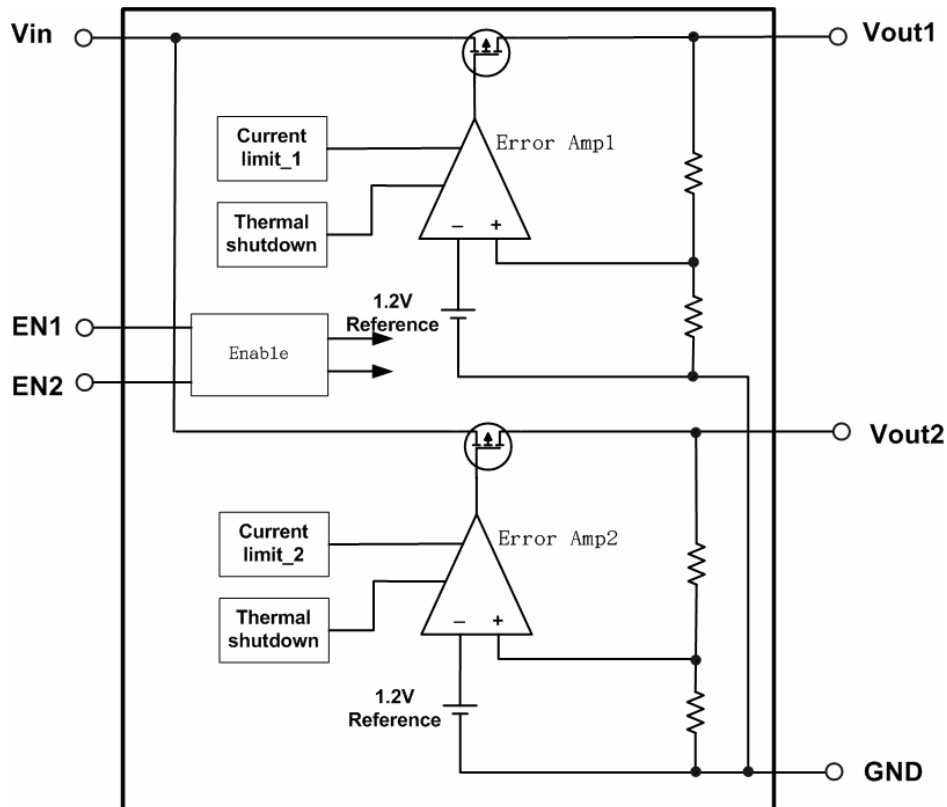

Figure 2.

## Ordering Information

Order Number	Package Type	Marking	Operating Temperature range
EUP7201-1.5/2.8VIR1	SOT23-6	N C	-40 °C to 85°C
EUP7201-1.8/2.8VIR1	SOT23-6	N A	-40 °C to 85°C
EUP7201-1.8/2.6VIR1	SOT23-6	N U	-40 °C to 85°C
EUP7201-1.8/3.3VIR1	SOT23-6	N H	-40 °C to 85°C
EUP7201-2.5/2.8VIR1	SOT23-6	N D	-40 °C to 85°C
EUP7201-2.8/1.2VIR1	SOT23-6	N P	-40 °C to 85°C
EUP7201-2.8/2.8VIR1	SOT23-6	N M	-40 °C to 85°C
EUP7201-2.8/3.0VIR1	SOT23-6	N K	-40 °C to 85°C
EUP7201-2.8/3.3VIR1	SOT23-6	N L	-40 °C to 85°C
EUP7201-3.0/3.0VIR1	SOT23-6	N N	-40 °C to 85°C
EUP7201-3.0/3.3VIR1	SOT23-6	N T	-40 °C to 85°C
EUP7201-3.3/3.3VIR1	SOT23-6	N J	-40 °C to 85°C

**Ordering Information (Continued)**

Order Number	Package Type	Marking	Operating Temperature range
EUP7201-1.8/2.8JIR1	TDFN-6	xxxxx 7201A	-40 °C to 85°C
EUP7201-1.5/2.8UIR1	USP-6	xxx NC	-40 °C to 85°C
EUP7201-1.8/2.8UIR1	USP-6	xxx NA	-40 °C to 85°C
EUP7201-1.8/2.6UIR1	USP-6	xxx NU	-40 °C to 85°C
EUP7201-1.8/3.3UIR1	USP-6	xxx NH	-40 °C to 85°C
EUP7201-2.5/2.8UIR1	USP-6	xxx ND	-40 °C to 85°C
EUP7201-2.8/1.2UIR1	USP-6	xxx NP	-40 °C to 85°C
EUP7201-2.8/2.8UIR1	USP-6	xxx NM	-40 °C to 85°C
EUP7201-2.8/3.0UIR1	USP-6	xxx NK	-40 °C to 85°C
EUP7201-2.8/3.3UIR1	USP-6	xxx NL	-40 °C to 85°C
EUP7201-3.0/3.0UIR1	USP-6	xxx NN	-40 °C to 85°C
EUP7201-3.0/3.3UIR1	USP-6	xxx NT	-40 °C to 85°C
EUP7201-3.3/3.3UIR1	USP-6	xxx NJ	-40 °C to 85°C

EUP7201- /

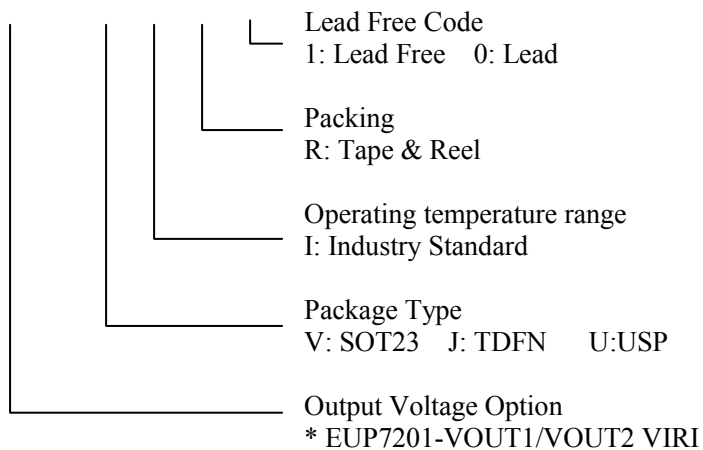

**Absolute Maximum Ratings**

Supply Input Voltage	-----	6V
Power Dissipation, $P_D$ @ $T_A = 25$		
SOT23-6	-----	0.4W
Package Thermal Resistance		
SOT23-6, $\theta_{JA}$	-----	250°C/W
Lead Temperature (Soldering, 10 sec.)	-----	260°C
Storage Temperature Range	-----	-65°C to 150°C
ESD Rating		
HBM	-----	2kV

**Recommended Operating Conditions**

Supply Input Voltage	-----	2.5V to 5.5V
Enable Input Voltage	-----	0V to 5.5V
Junction Temperature Range	-----	-40°C to 125°C

**Electrical Characteristics**

$V_{IN} = (V_{OUT} + 0.5V)$  or  $V_{IN} = 2.5V$  whichever is greater,  $C_{IN} = C_{OUT} = 1\mu F$ ,  $EN1 = EN2 = V_{IN}$ .  $T_A = 25^\circ C$ .  
 Unless otherwise noted

Symbol	Parameter	Conditions	EUP7201			Unit
			Min	Typ	Max.	
$V_{OUT}$	Output voltage	$I_L = 30mA$	-2		2	%
		$I_L = 30mA, T_A = -40^\circ C \sim 85^\circ C$ .	-3		3	
$I_{MAX}$	Maximum Output Current	Continuous, $T_A = -40^\circ C \sim 85^\circ C$ .	150			mA
$I_{LIM}$	Current Limit	Output Grounded (Steady State)	180	300		mA
$I_G$	Quiescent Current	No Load (Both LDOs)		110	180	$\mu A$
		$I_{OUT} = 150mA$ (Both LDOs)		260		$\mu A$
$V_{DROP}$	Dropout Voltage	$I_{OUT} = 30mA$		30		mV
		$I_{OUT} = 100mA, T_A = -40^\circ C \sim 85^\circ C$ .		80	220	mV
$V_{OUT}$	Load Regulation	$1mA < I_{OUT} < 150mA$		13	60	mV
$V_{LINE}$	Line Regulation	$V_{IN} = V_{OUT} + 0.5V$ to 5.5V $I_{OUT} = 1mA$		0.02	0.2	%/V
$V_{IH}$	EN Input High Threshold	$V_{IN} = 2.5V$ to 5.5V, $T_A = -40^\circ C \sim 85^\circ C$ .	1.6			V
$V_{IL}$	EN Input Low Threshold	$V_{IN} = 2.5V$ to 5.5V, $T_A = -40^\circ C \sim 85^\circ C$ .			0.4	V
$I_{SD}$	EN Input Bias Current	$EN = GND$ or $V_{IN}$			0.1	$\mu A$
$I_{GSD}$	Shutdown Supply Current	$EN1 = EN2 = GND$		0.01	1	$\mu A$
$T_{SD}$	Thermal Shutdown Temperature			155		
$T_{SD}$	Thermal Shutdown Hysteresis			15		
PSRR	Ripple Rejection Rate	$V_{IN} = (V_{OUT} + 1V)$ DC + 0.5V p-p AC $I_{OUT} = 1mA, f = 1kHz$		60		dB

Typical Operating Characteristics

Output Voltage vs. Output Current (VOUT=1.8V)

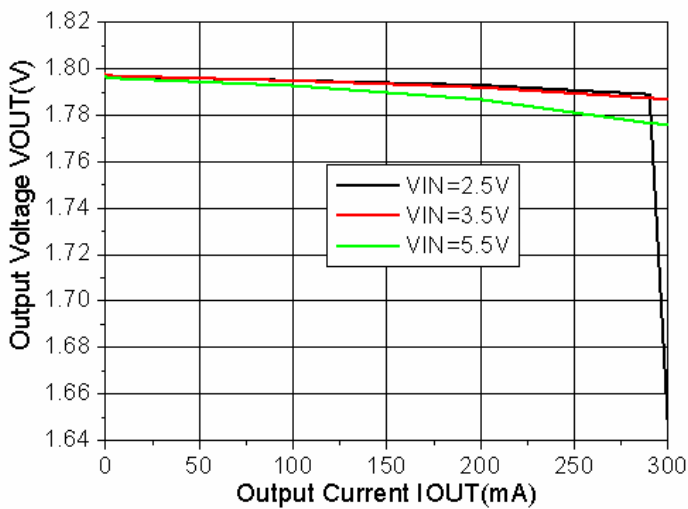

Output Voltage vs. Output Current (VOUT=2.8V)

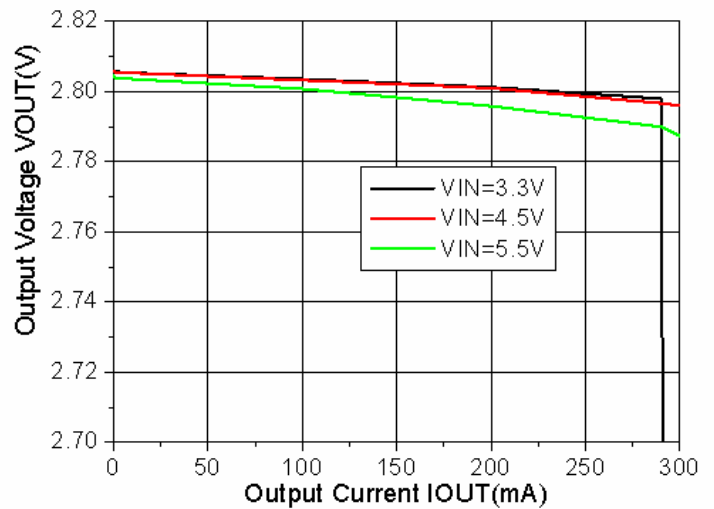

Output Voltage vs. Input Voltage (VOUT=1.8V)

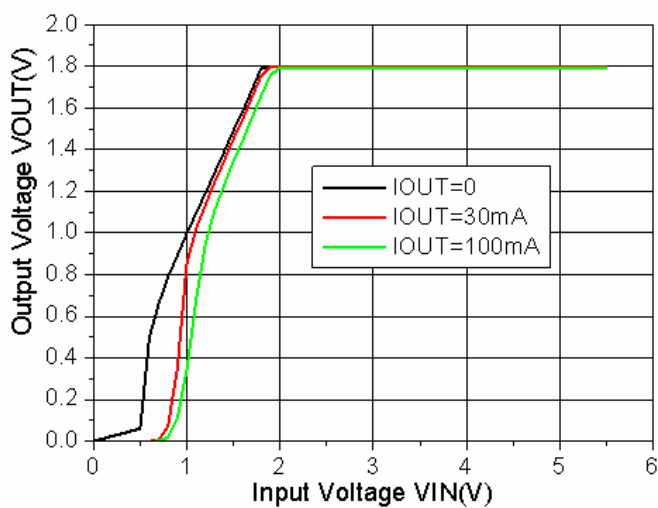

Output Voltage vs. Input Voltage (VOUT=1.8V)

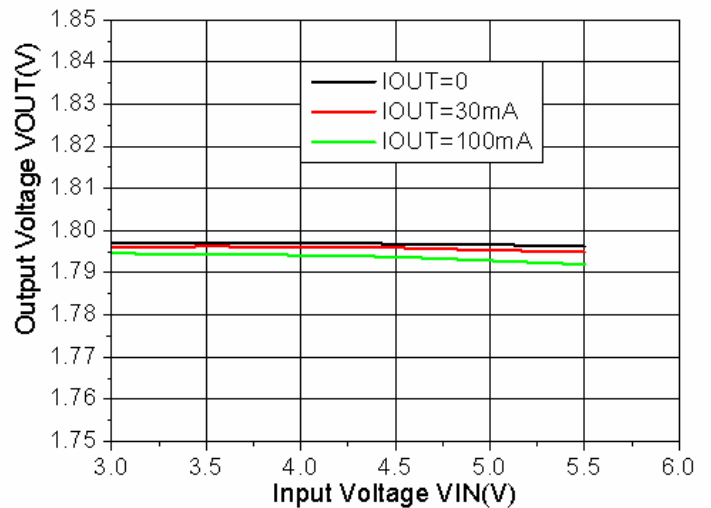

Output Voltage vs. Input Voltage (VOUT=2.8V)

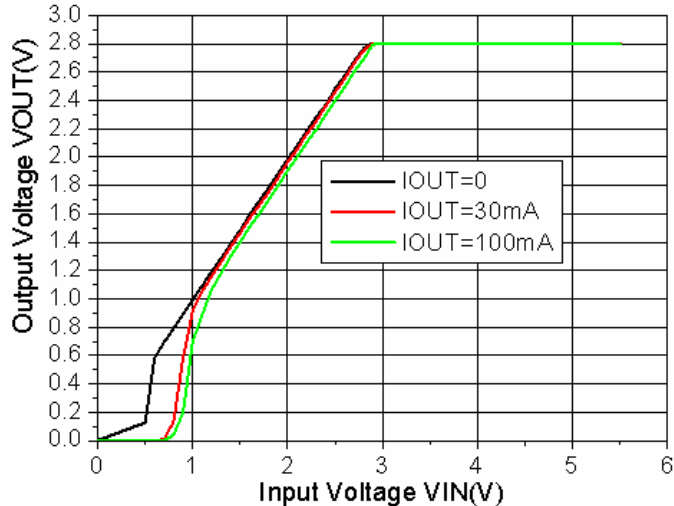

Output Voltage vs. Input Voltage (VOUT=2.8V)

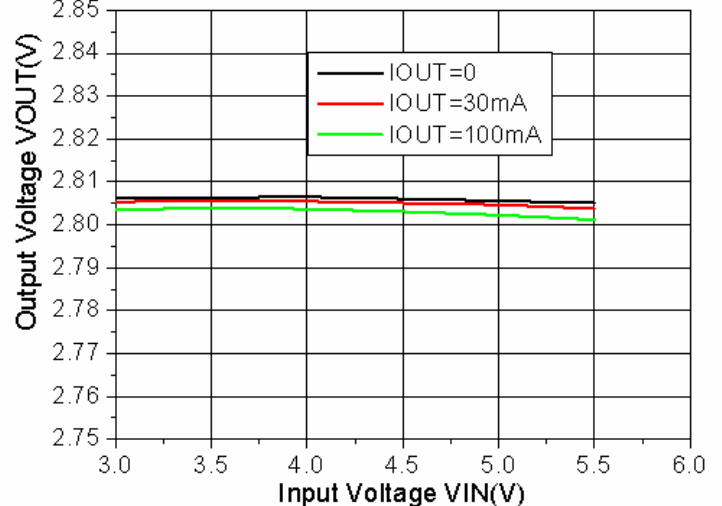

Dropout Voltage vs. Output Current

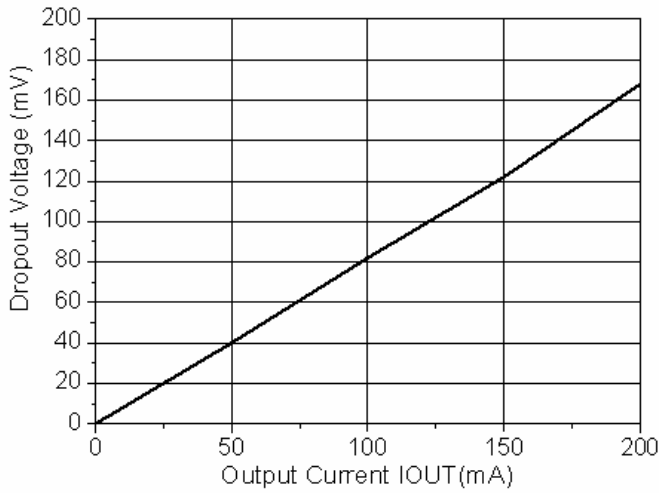

Dropout Voltage vs. Temperature

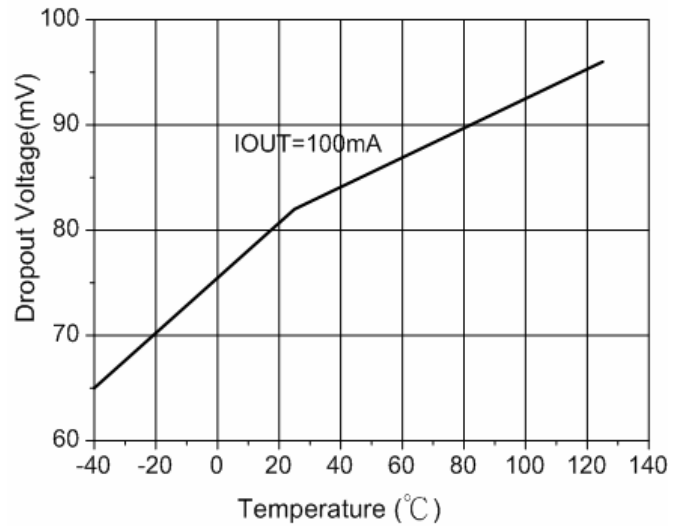

Quiescent Current vs. Input Voltage

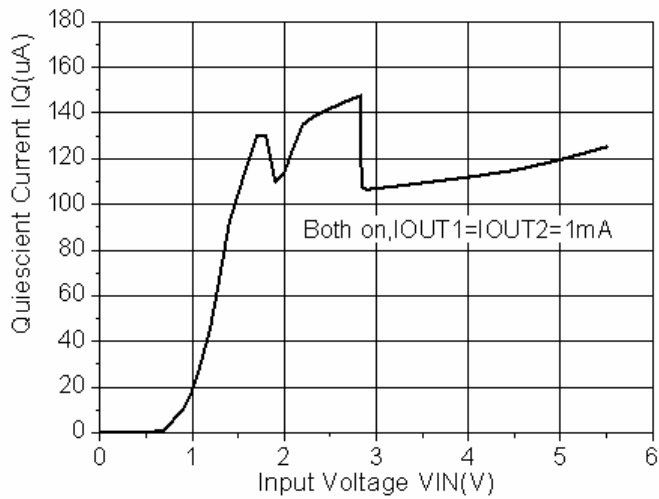

Output Voltage vs. Temperature (VOUT=1.8V)

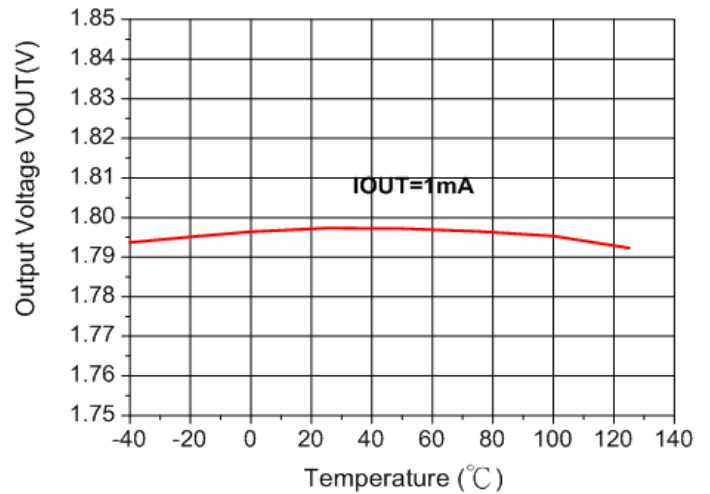

Output Voltage vs. Temperature (VOUT=2.8V)

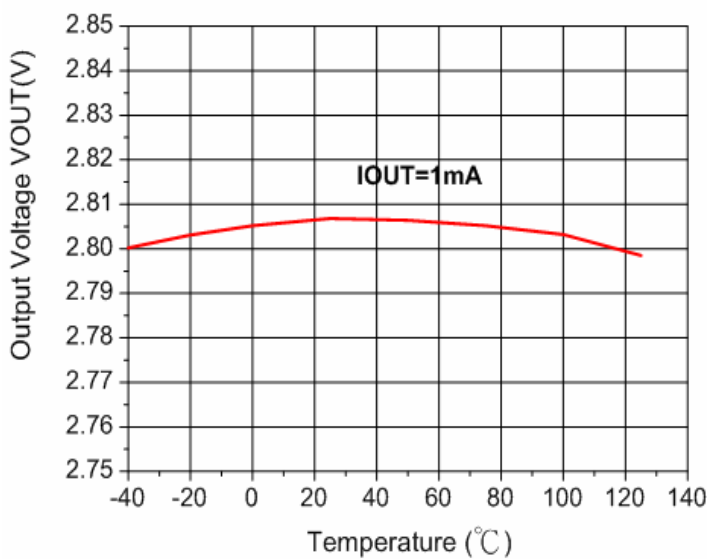

Quiescent Current vs. Temperature

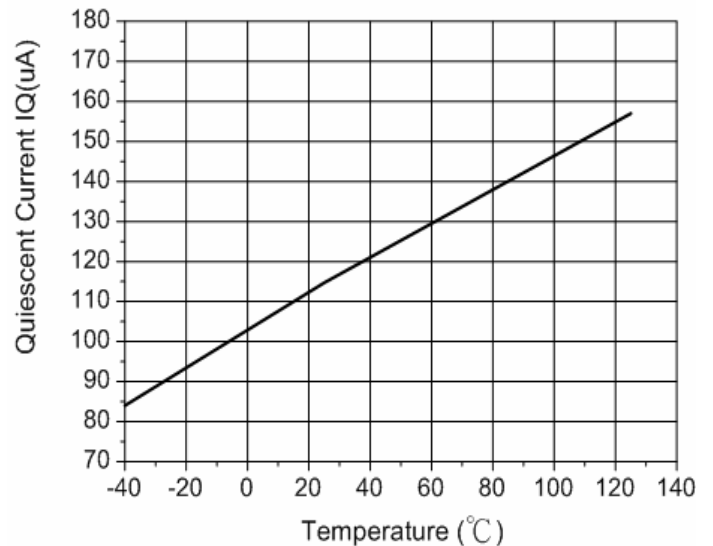

Line Transient Response ( $V_{IN}=3.5V$  to  $4.5V$ )

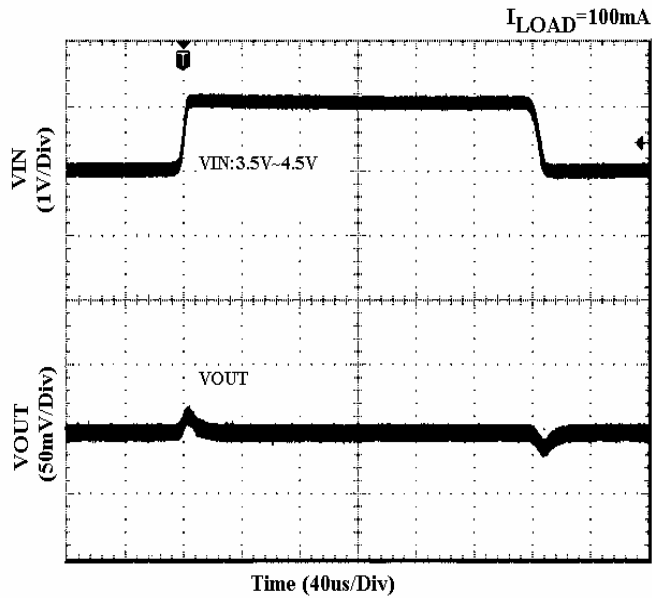

Load Transient Response ( $I_{LOAD} = 1mA$  to  $50mA$ )

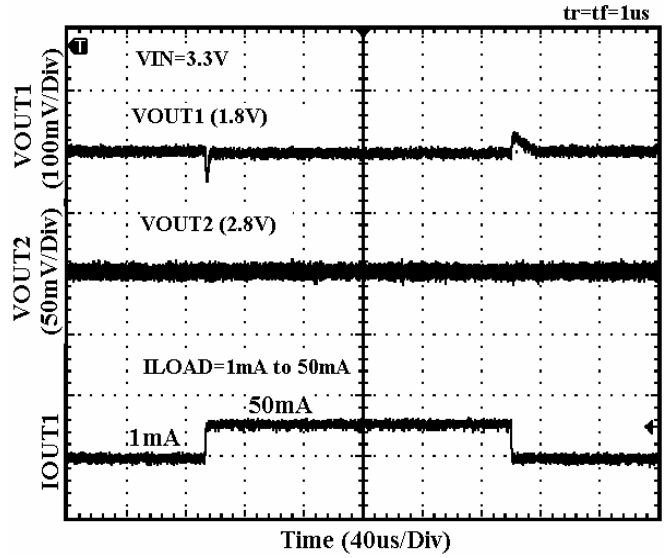

Load Transient Response ( $I_{LOAD} = 10mA$  to  $50mA$ )

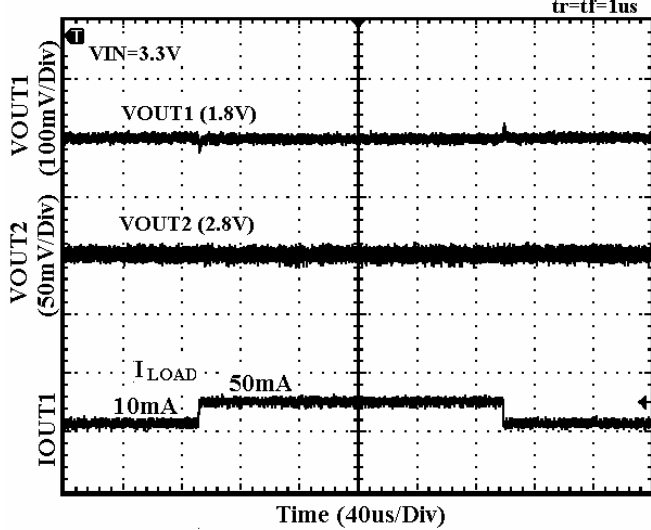

Load Transient Response ( $I_{LOAD} = 1mA$  to  $150mA$ )

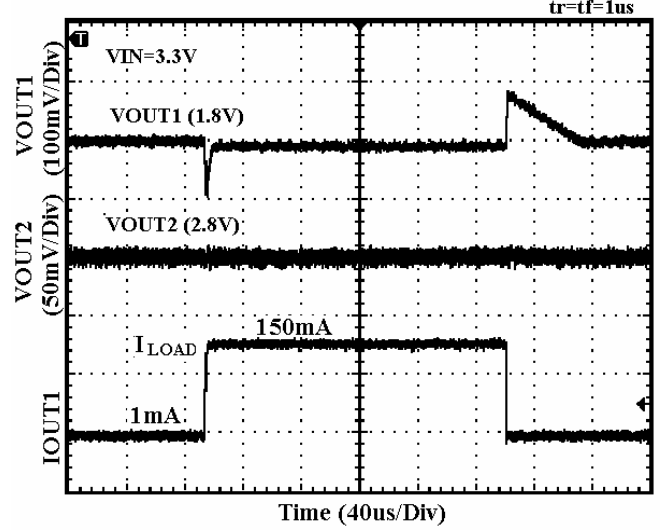

Load Transient Response ( $I_{LOAD} = 10mA$  to  $150mA$ )

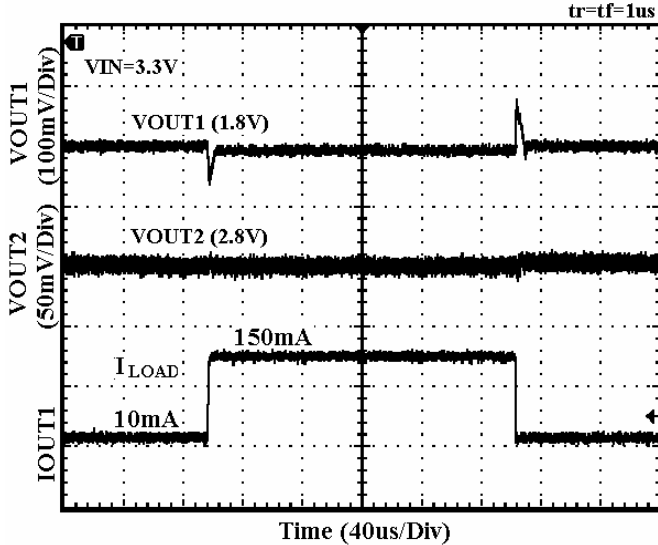

Short Circuit Current Limit

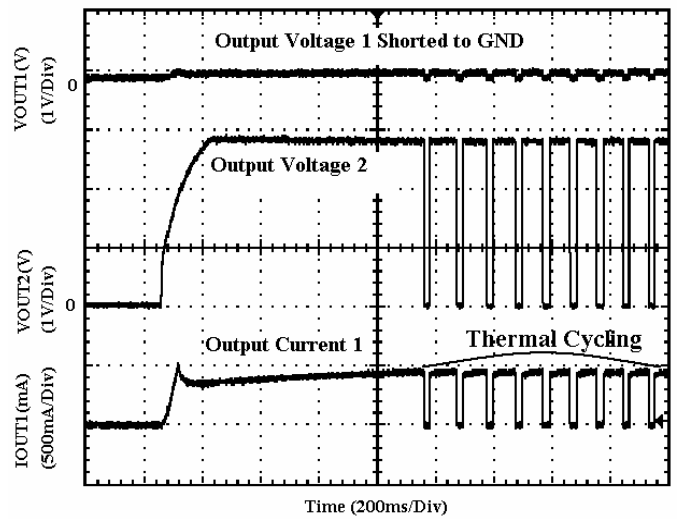



Output1 Niose(10Hz to 100KHz)

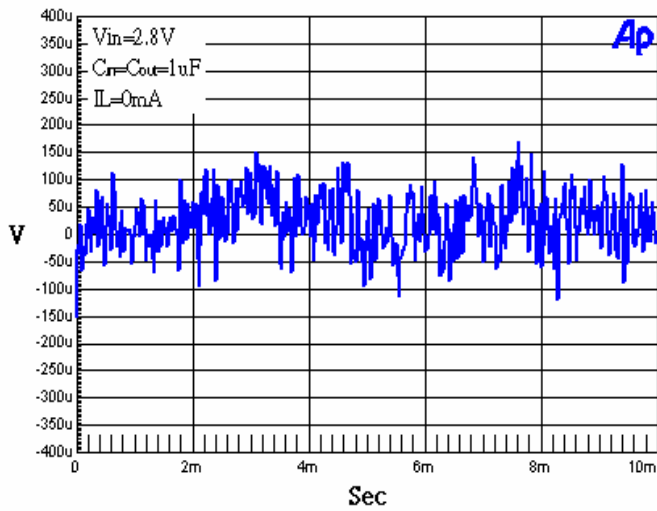

Output2 Niose(10Hz to 100kHz)

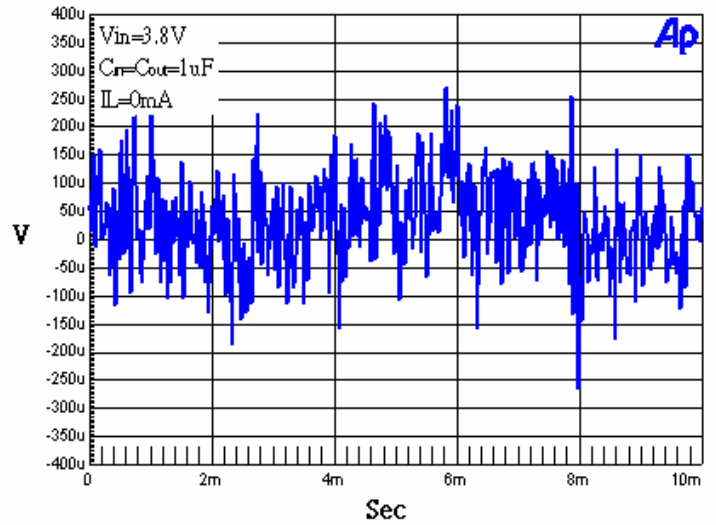

PSRR

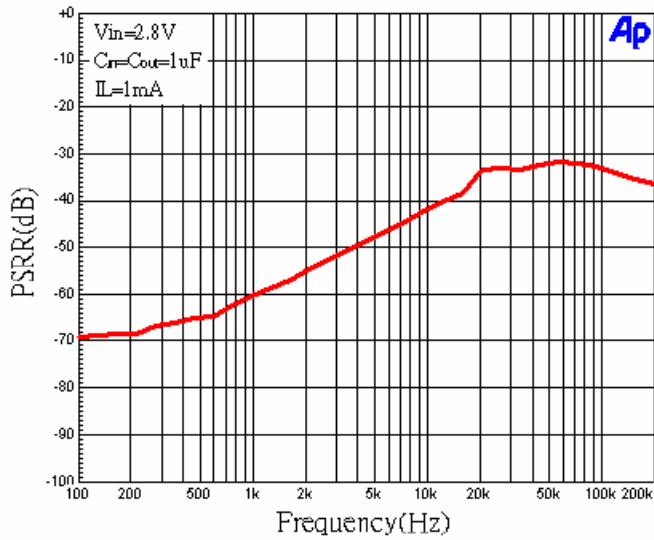

PSRR

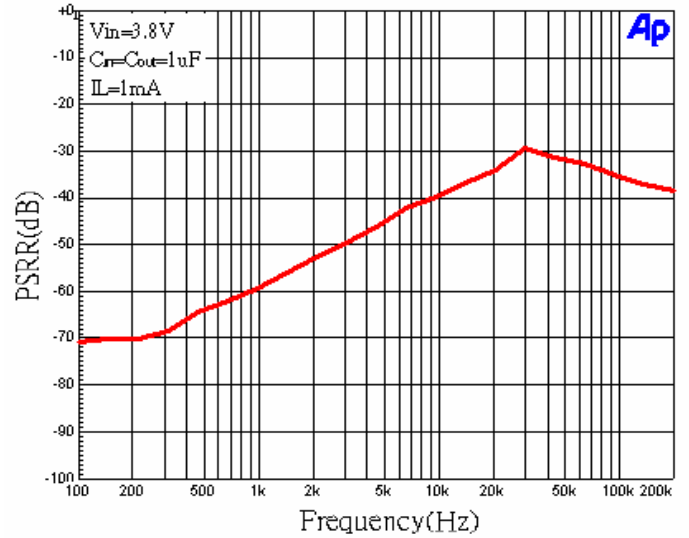

## Application Note

### External Capacitors

Like any low-dropout regulator, the EUP7201 requires external capacitors for regulator stability. The EUP7201 is specifically designed for portable applications requiring minimum board space and smallest components. These capacitors must be correctly selected for good performance.

### Input Capacitor

An input capacitance of  $\approx 1\mu\text{F}$  is required between the EUP7201 input pin and ground (the amount of the capacitance may be increased without limit).

This capacitor must be located a distance of not more than 1cm from the input pin and returned to a clean analog ground. Any good quality ceramic, tantalum, or film capacitor may be used at the input.

If a tantalum capacitor is used at the input, it must be guaranteed by the manufacturer to have a surge current rating sufficient for the application.

There are no requirements for the ESR on the input capacitor, but tolerance and temperature coefficient must be considered when selecting the capacitor to ensure the capacitance will be  $\approx 1\mu\text{F}$  over the entire operating temperature range.

### Output Capacitor

The EUP7201 is designed specifically to work with very small ceramic output capacitors. A ceramic capacitor (temperature characteristics X7R, X5R, Z5U, or Y5V) in 1 to  $22\mu\text{F}$  range with  $5\text{m}\Omega$  to  $500\text{m}\Omega$  ESR range is suitable in the EUP7201 application circuit.

The output capacitor must meet the requirement for minimum amount of capacitance and also have an ESR (Equivalent Series Resistance) value which is within a stable range ( $5\text{m}\Omega$  to  $500\text{m}\Omega$ )

### No-Load Stability

The EUP7201 will remain stable and in regulation with no external load. This is specially important in CMOS RAM keep-alive applications.

### Capacitor Characteristics

The EUP7201 is designed to work with ceramic capacitors on the output to take advantage of the benefits they offer: for capacitance values in the range of  $1\mu\text{F}$  to  $4.7\mu\text{F}$  range, ceramic capacitors are the smallest, least expensive and have the lowest ESR values (which makes them best for eliminating high frequency noise). The ESR of a typical  $1\mu\text{F}$  ceramic capacitor is in the range of  $20\text{m}\Omega$  to  $40\text{m}\Omega$ , which easily meets the ESR requirement for stability by the EUP7201.

The ceramic capacitor's capacitance can vary with temperature. The capacitor type X7R, which operates over a temperature range of  $-55^\circ\text{C}$  to  $+125^\circ\text{C}$ , will only vary the capacitance to within  $\pm 15\%$ . Most large value ceramic capacitors ( $\approx 2.2\mu\text{F}$ ) are manufactured with Z5U or Y5V temperature characteristics. Their capacitance can drop by more than 50% as the temperature goes from  $25^\circ\text{C}$  to  $85^\circ\text{C}$ . Therefore, X7R is recommended over Z5U and Y5V in applications where the ambient temperature will change significantly above or below  $25^\circ\text{C}$ .

### On/Off Input Operation

The EUP7201 is turned off by pulling the  $V_{\text{EN}}$  pin low, and turned on by pulling it high. If this feature is not used, the  $V_{\text{EN}}$  pin should be tied to  $V_{\text{IN}}$  to keep the regulator output on at all time. To assure proper operation, the signal source used to drive the  $V_{\text{EN}}$  input must be able to swing above and below the specified turn-on/off voltage thresholds listed in the Electrical Characteristics section under  $V_{\text{IL}}$  and  $V_{\text{IH}}$ .

## Packaging Information

## SOT23-6

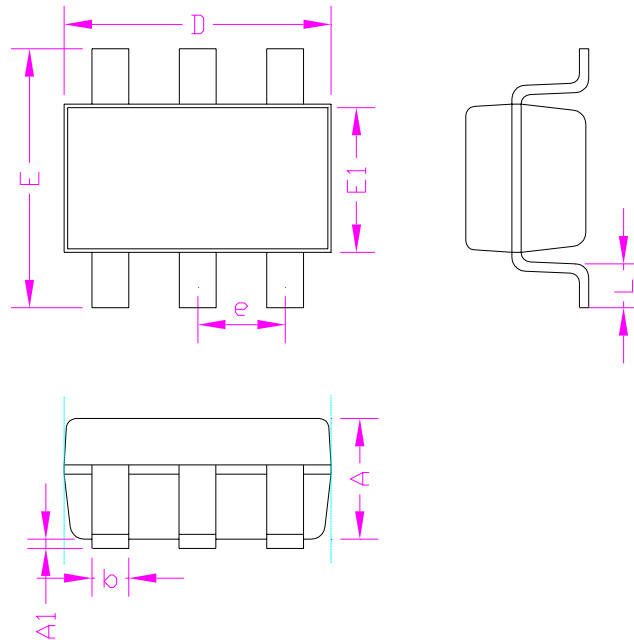

SYMBOLS	MILLIMETERS		INCHES	
	MIN.	MAX.	MIN.	MAX.
A	-	1.45	-	0.057
A1	0.00	0.15	0.000	0.006
b	0.30	0.50	0.012	0.020
D	2.90		0.114	
E1	1.60		0.063	
e	0.95		0.037	
E	2.60	3.00	0.102	0.118
L	0.30	0.60	0.012	0.024

TDFN-6

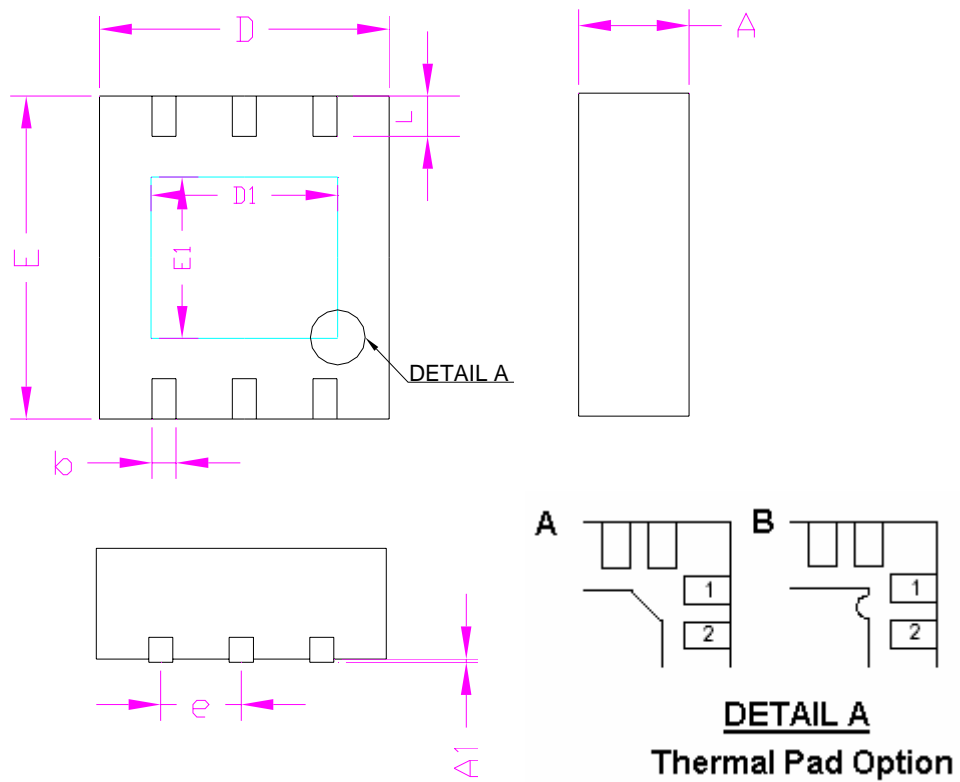

SYMBOLS	MILLIMETERS		INCHES	
	MIN.	MAX.	MIN.	MAX.
A	0.70	0.80	0.028	0.031
A1	0.00	0.05	0.000	0.002
b	0.30	0.50	0.012	0.020
D	2.90	3.10	0.114	0.122
D1	2.30		0.090	
E	2.90	3.10	0.114	0.122
E1	1.50		0.059	
e	0.95		0.037	
L	0.38	0.58	0.015	0.023

USP-6

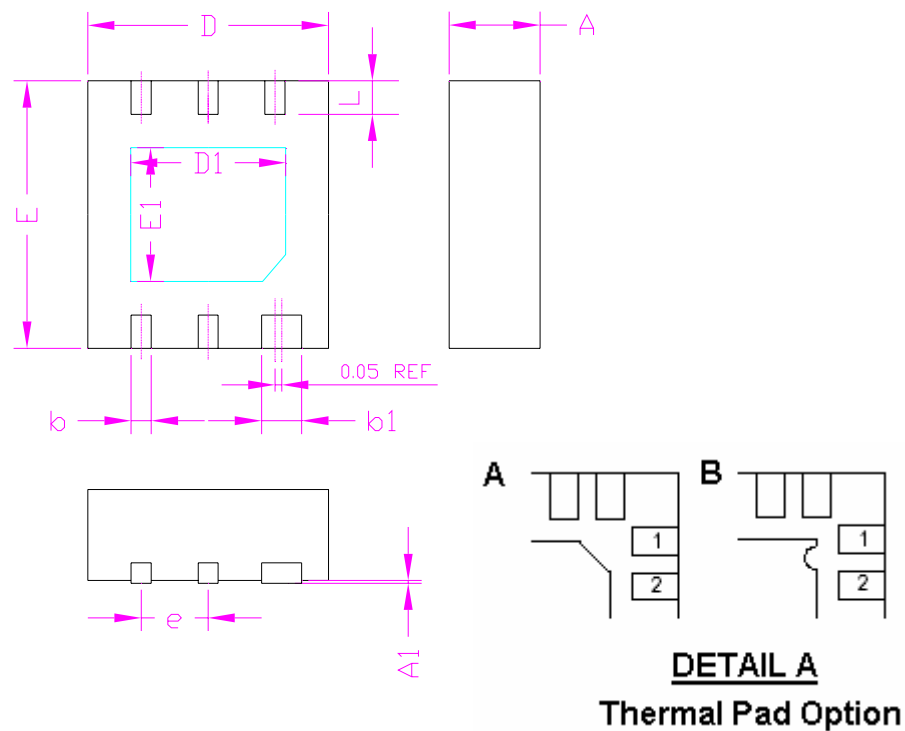

SYMBOLS	MILLIMETERS		INCHES	
	MIN.	MAX.	MIN.	MAX.
A	0.70	0.80	0.028	0.031
A1	0.00	0.05	0.000	0.002
b	0.10	0.30	0.004	0.012
b1	0.20	0.40	0.008	0.016
D	1.70	1.90	0.067	0.075
D1	1.50		0.059	
E	1.90	2.10	0.075	0.083
E1	0.90		0.035	
e	0.50		0.020	
L	0.15	0.35	0.006	0.014