

SEMISTACK

Antiparallel thyristors for softstart

SKKQ 350

Features

- Compact design
- Thyristor with amplifying gate
- Pressure contact technology

Typical Applications

- Soft Starters

1) T_{vjmax} up to 150°C is allowable for overload conditions, max. time period for the overload condition is 25s.

Absolute Maximum Ratings

Symbol	Conditions	Values	Units
$I_{overload}$	W1C; sin. 180°; 20 sec.; $T_{vjmax} = 150\text{ °C}$; $T_{vjstart} = 40\text{ °C}$	1225	A
I_{TSM}	$T_{vj} = 25\text{ °C}$; 10 ms	9500	A
	$T_{vj} = 125\text{ °C}$; 10 ms	8000	A
I^2t	$T_{vj} = 25\text{ °C}$; 8,3 ... 10 ms	451000	A ² s
	$T_{vj} = 125\text{ °C}$; 8,3 ... 10 ms	320000	A ² s
SKKQ 350/14			
V_{RSM}		1500	V
V_{RRM}, V_{DRM}		1400	V
SKKQ 430/18			
V_{RSM}		1900	V
V_{RRM}, V_{DRM}		1800	V
T_{vj}		-40 ... +125 ¹⁾	°C
T_{stg}		-40 ... +125	°C

Characteristics

Symbol	Conditions	min.	typ.	max.	Units
V_T	$T_{vj} = 25\text{ °C}$; $I_T = 1500\text{ A}$			1,65	V
$V_{T(TO)}$	$T_{vj} = 125\text{ °C}$			0,9	V
r_T	$T_{vj} = 125\text{ °C}$			0,5	mΩ
I_{DD}, I_{RD}	$T_{vj} = 125\text{ °C}$; $V_{RD} = V_{RRM}$; per module			72	mA
t_{gd}	$T_{vj} = 25\text{ °C}$; $I_G = 1\text{ A}$; $di_G/dt = 1\text{ A}/\mu\text{s}$		1		μs
t_{gr}	$V_D = 0,67 * V_{DRM}$		2		μs
$(dv/dt)_{cr}$	$T_{vj} = 125\text{ °C}$		1000		V/μs
$(di/dt)_{cr}$	$T_{vj} = 125\text{ °C}$; $f = 50 \dots 60\text{ Hz}$		200		A/μs
t_q	$T_{vj} = 125\text{ °C}$		150		μs
I_H	$T_{vj} = 25\text{ °C}$		150	500	mA
I_L	$T_{vj} = 25\text{ °C}$; $R_G = 33\ \Omega$		300	2000	mA
V_{GT}	$T_{vj} = 25\text{ °C}$; d.c.	3			V
I_{GT}	$T_{vj} = 25\text{ °C}$; d.c.	200			mA
V_{GD}	$T_{vj} = 125\text{ °C}$; d.c.			0,25	V
I_{GD}	$T_{vj} = 125\text{ °C}$; d.c.			10	mA
$R_{th(j-s)}$	cont.; per thyristor			0,066	K/W
M_t			5 ± 15%		Nm
m	approx.		1200		g
Case				SKKQ 350	

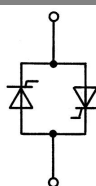

W1C

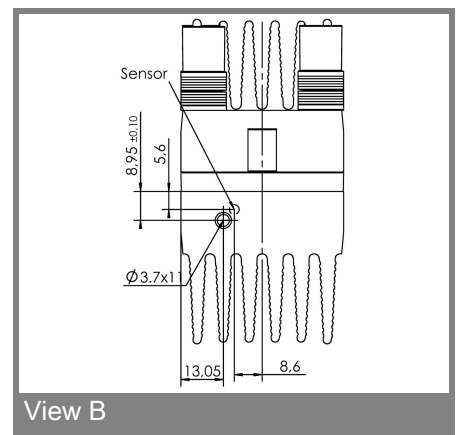
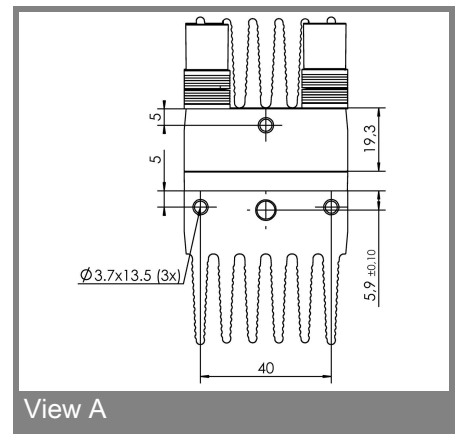
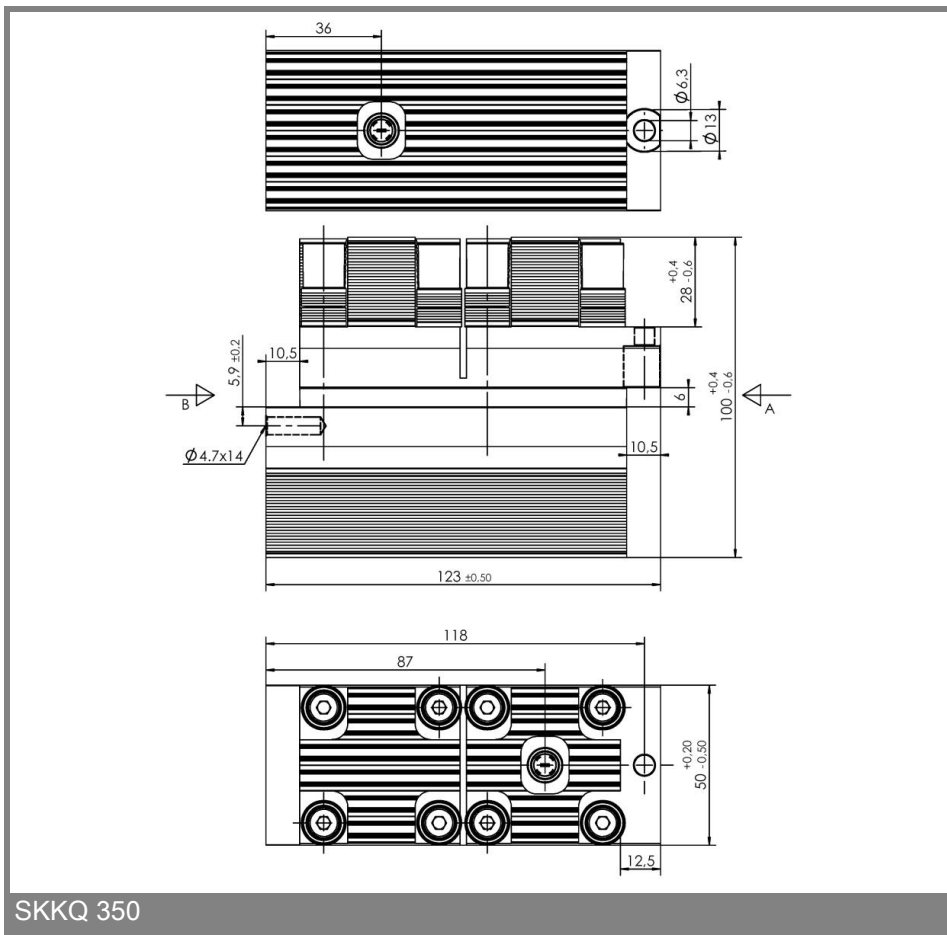

This technical information specifies semiconductor devices but promises no characteristics. No warranty or guarantee expressed or implied is made regarding delivery, performance or suitability.