

TA48015F

1.5 V

Three-Terminal Low Dropout Voltage Regulator with Output Current of 1 A

The TA48015F consists of fixed-positive-output, low-dropout regulators with an output current of 1 A (max) that utilize V-PNP transistors for the output stage. This product responds to the need for low-voltage and low-power dissipation devices for use in consumer electronics and industrial appliances.

Features

- Maximum output current: 1 A
- Output voltage accuracy: $V_{OUT} \pm 3\%$ (@ $T_j = 25^\circ\text{C}$)
- Low standby current: 800 μA (typ.) (@ $I_{OUT} = 0\text{ A}$)
- Low starting quiescent current
- Low-dropout voltage: $V_D = 0.8\text{ V}$ (max) (@ $I_{OUT} = 0.5\text{ A}$)
- Protection function: over-heat/over-current
- Package type: PW-MOLD
- TA48015F has a lead bending type package which is a surface-mountable package and can be used for reflow soldering.

Pin Assignment

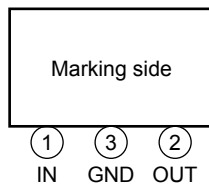

Marking

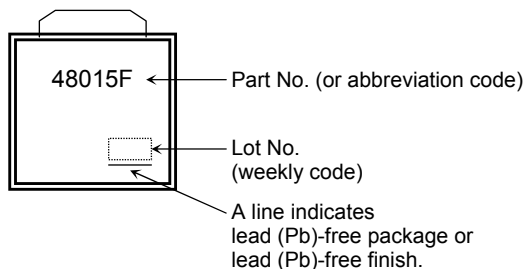

How to Order

	Product No.	Package	Packing Type and Unit for Orders
(1)	TA48015F	PW-MOLD: Straight-lead package	Loose in bag: 200 (1 bag)
(2)	TA48015F (TE16L1, N)	PW-MOLD: Surface-mount package	Embossed-tape packing: 2000 (1 tape)

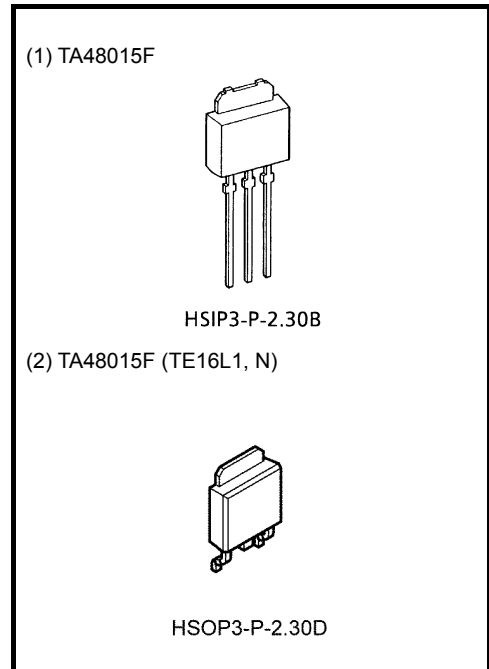

Weight
 HSIP3-P-2.30B : 0.36 g (typ.)
 HSOP3-P-2.30D : 0.36 g (typ.)

Block Diagram

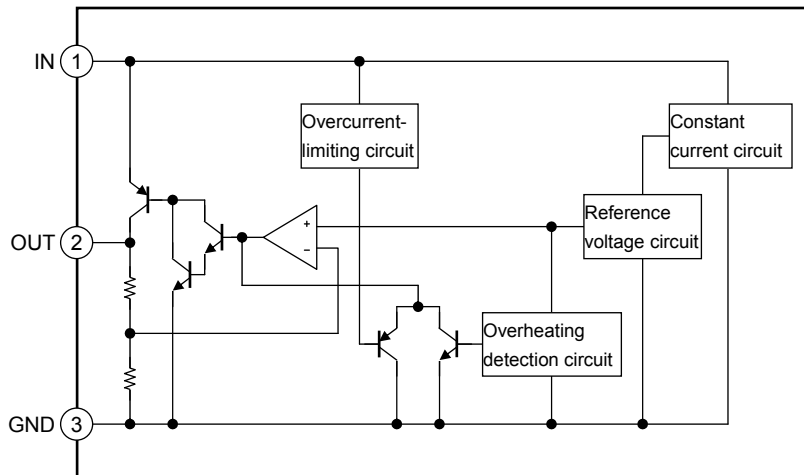

Absolute Maximum Ratings (Ta = 25°C)

Characteristic	Symbol	Rating	Unit
Input voltage	V_{IN}	16	V
Output current	I_{OUT}	1	A
Operating temperature	$T_{a (opr)}$	-40~85	°C
Junction temperature	T_j	150	°C
Storage temperature	T_{stg}	-55~150	°C
Power dissipation	(Ta = 25°C)	1	W
	(Tc = 25°C)	10	
Thermal resistance	(junction to ambient)	$R_{th (j-a)}$	°C/W
	(junction to case)	$R_{th (j-c)}$	

Note 1: External current and voltage ((including negative voltage) should not be applied to pins not specified.

Note 2: Using continuously under heavy loads (e.g. the application of high temperature/current/voltage and the significant change in temperature, etc.) may cause this product to decrease in the reliability significantly even if the operating conditions (i.e. operating temperature/current/voltage, etc.) are within the absolute maximum ratings and the operating ranges.

Please design the appropriate reliability upon reviewing the Toshiba Semiconductor Reliability Handbook ("Handling Precautions"/Derating Concept and Methods) and individual reliability data (i.e. reliability test report and estimated failure rate, etc).

Protection Function (reference)

Characteristics	Symbol	Test Condition	Min	Typ.	Max	Unit
Thermal shutdown	$T_{SD}(T_j)$	—	—	160	—	°C
Peak circuit current	I_{PEAK}	$V_{IN} = 3.5 V, T_j = 25^\circ C$	—	1.7	—	A
		$V_{IN} = 12 V, T_j = 25^\circ C$	—	1.8	—	
Short circuit current	I_{SC}	$V_{IN} = 3.5 V, T_j = 25^\circ C$	—	1.7	—	A
		$V_{IN} = 12 V, T_j = 25^\circ C$	—	1.8	—	

Note 3: The maximum ratings should not be exceeded when the IC is actually used.

TA48015F

Electrical Characteristics

(Unless otherwise specified, $C_{IN} = 0.33 \mu\text{F}$, $C_{OUT} = 10 \mu\text{F}$, $T_j = 25^\circ\text{C}$)

Characteristics	Symbol	Test Conditions	Min	Typ.	Max	Unit
Output voltage	V_{OUT}	$V_{IN} = 3.5 \text{ V}$, $I_{OUT} = 0.5 \text{ A}$	1.455	1.5	1.545	V
		$2.5 \text{ V} \leq V_{IN} \leq 12 \text{ V}$, $5 \text{ mA} \leq I_{OUT} \leq 1 \text{ A}$, $0^\circ\text{C} \leq T_j \leq 125^\circ\text{C}$	1.432	1.5	1.568	
Line regulation	Reg·line	$2.5 \text{ V} \leq V_{IN} \leq 12 \text{ V}$, $I_{OUT} = 0.5 \text{ A}$	—	5	20	mV
Load regulation	Reg·load	$V_{IN} = 3.5 \text{ V}$, $5 \text{ mA} \leq I_{OUT} \leq 1 \text{ A}$	—	5	20	mV
Quiescent current	I_B	$2.5 \text{ V} \leq V_{IN} \leq 12 \text{ V}$, $I_{OUT} = 0 \text{ A}$	—	0.8	1.8	mA
		$2.5 \text{ V} \leq V_{IN} \leq 12 \text{ V}$, $I_{OUT} = 1 \text{ A}$	—	10	20	
Starting quiescent current	I_{Bstart}	$V_{IN} = 2.1 \text{ V}$, $I_{OUT} = 0 \text{ A}$	—	0.7	5	mA
		$V_{IN} = 2.5 \text{ V}$, $I_{OUT} = 1 \text{ A}$	—	10	30	
Output noise voltage	V_{NO}	$V_{IN} = 3.5 \text{ V}$, $I_{OUT} = 50 \text{ mA}$ $10 \text{ Hz} \leq f \leq 100 \text{ kHz}$	—	75	—	μVrms
Ripple rejection	R.R.	$2.5 \text{ V} \leq V_{IN} \leq 12 \text{ V}$, $I_{OUT} = 50 \text{ mA}$ $f = 120 \text{ Hz}$	54	70	—	dB
Dropout voltage	V_D	$I_{OUT} = 0.5 \text{ A}$	—	0.6	0.8	V
		$I_{OUT} = 1 \text{ A}$	—	0.8	—	
Average temperature coefficient of output voltage	T_{CVO}	$V_{IN} = 3.5 \text{ V}$, $I_{OUT} = 5 \text{ mA}$, $0^\circ\text{C} \leq T_j \leq 125^\circ\text{C}$	—	0.14	—	$\text{mV}/^\circ\text{C}$

Electrical Characteristics for All Products

Generally, the characteristics of power supply ICs change according to temperature fluctuations. The specification $T_j = 25^\circ\text{C}$ is based on a state where temperature increase has no effect (assuming no fluctuation in the characteristics) as ascertained by pulse tests.

Standard Application Circuit

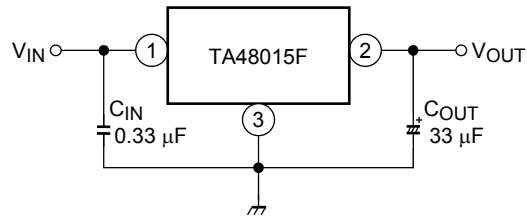

Be sure to connect a capacitor near the input terminal and output terminal between both terminals and GND. The capacitances should be determined experimentally. In particular, adequate investigation should be made so that there is no problem even in high or low temperatures.

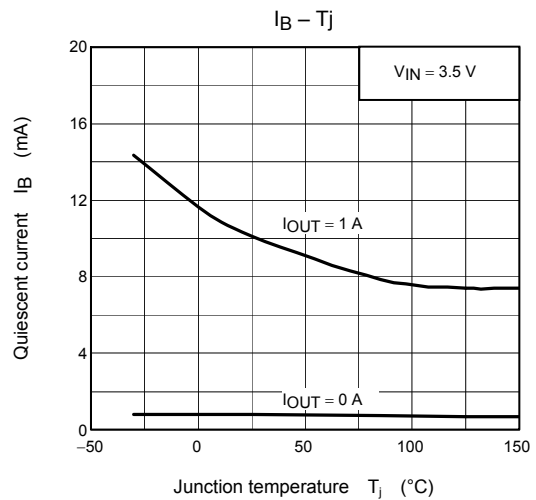
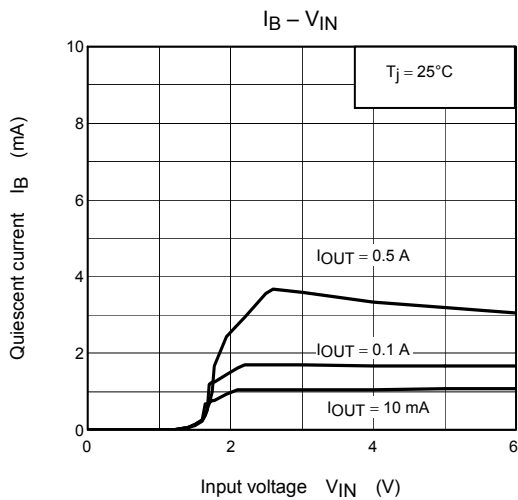
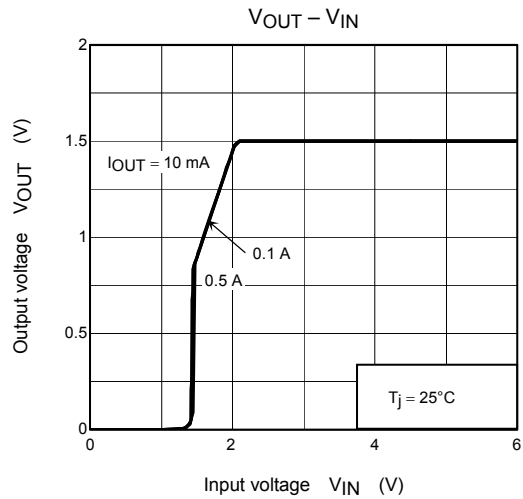
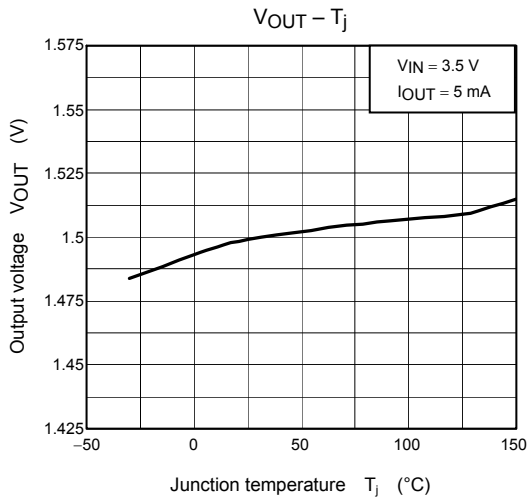
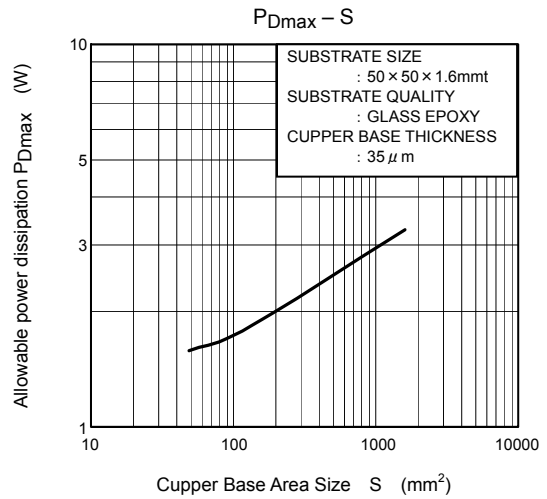
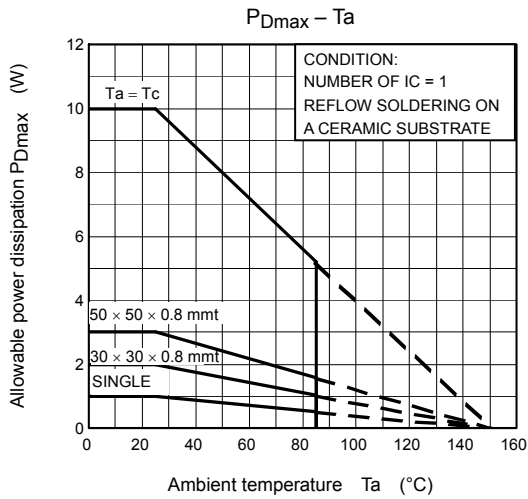

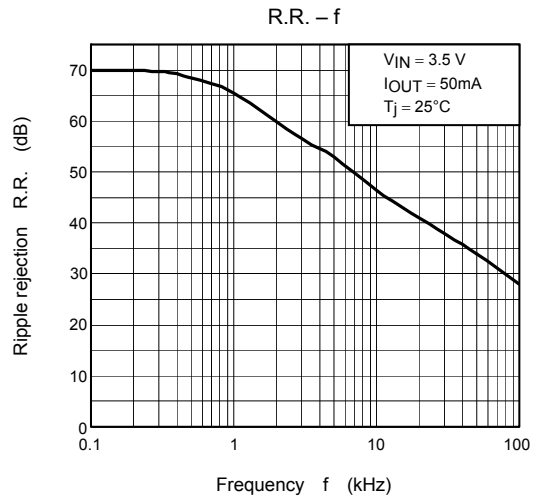
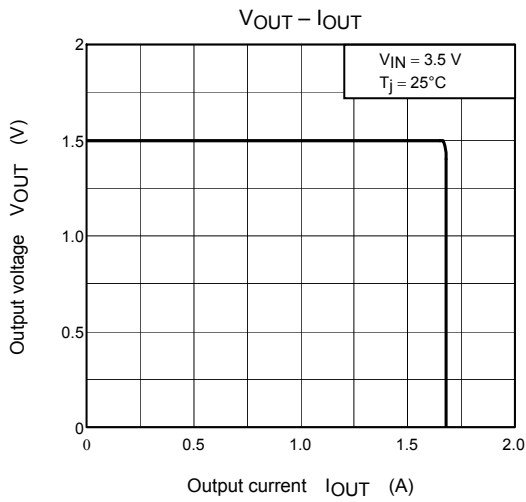
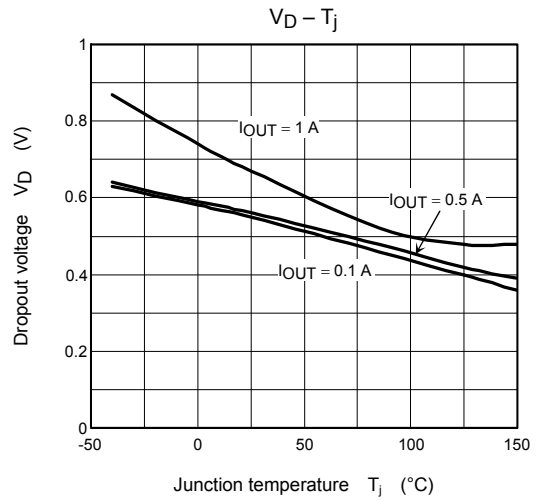
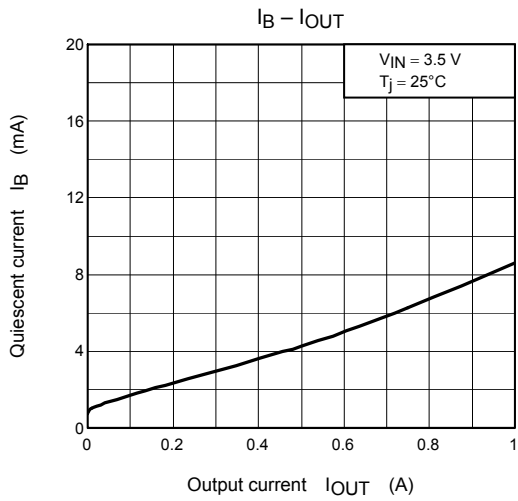

Package Dimensions

HSIP3-P-2.30B

Unit : mm

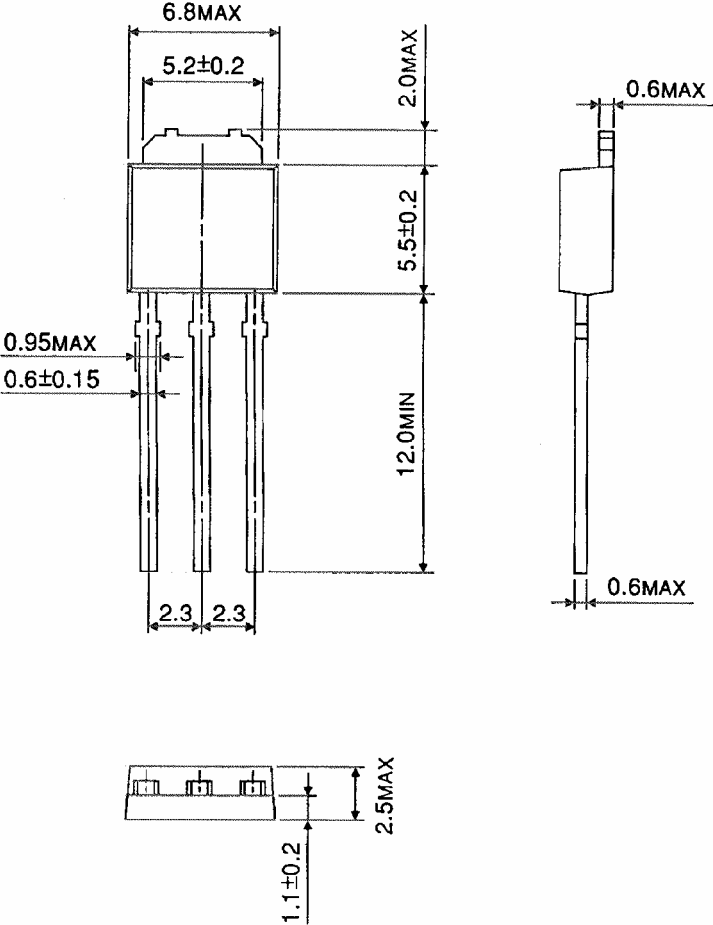

Weight: 0.36 g (typ.)

Package Dimensions

HSOP3-P-2.30D

Unit: mm

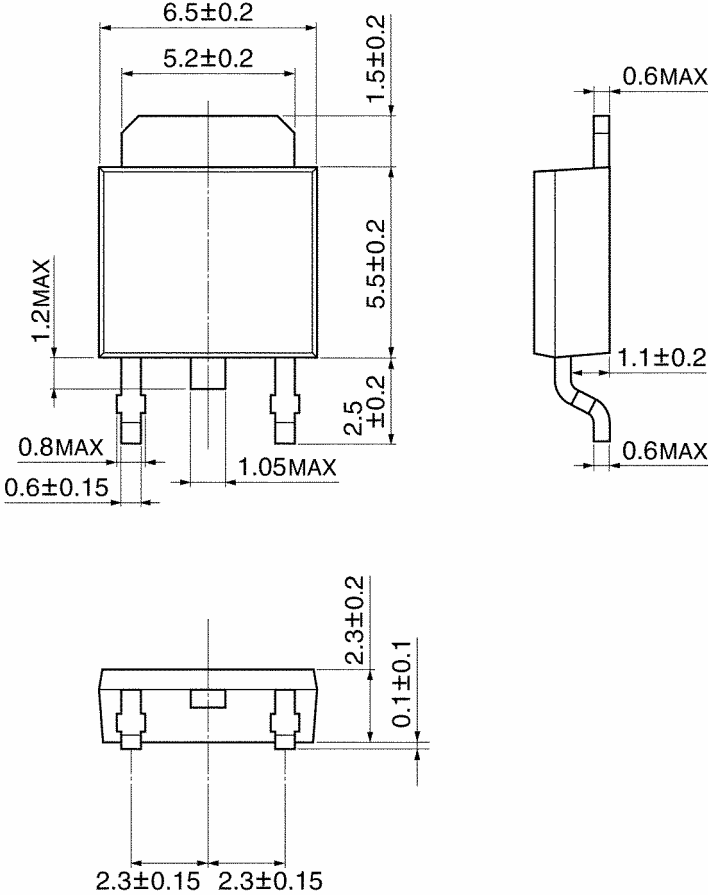

Weight: 0.36 g (typ.)

RESTRICTIONS ON PRODUCT USE

20070701-EN

- The information contained herein is subject to change without notice.
- TOSHIBA is continually working to improve the quality and reliability of its products. Nevertheless, semiconductor devices in general can malfunction or fail due to their inherent electrical sensitivity and vulnerability to physical stress. It is the responsibility of the buyer, when utilizing TOSHIBA products, to comply with the standards of safety in making a safe design for the entire system, and to avoid situations in which a malfunction or failure of such TOSHIBA products could cause loss of human life, bodily injury or damage to property.
In developing your designs, please ensure that TOSHIBA products are used within specified operating ranges as set forth in the most recent TOSHIBA products specifications. Also, please keep in mind the precautions and conditions set forth in the "Handling Guide for Semiconductor Devices," or "TOSHIBA Semiconductor Reliability Handbook" etc.
- The TOSHIBA products listed in this document are intended for usage in general electronics applications (computer, personal equipment, office equipment, measuring equipment, industrial robotics, domestic appliances, etc.). These TOSHIBA products are neither intended nor warranted for usage in equipment that requires extraordinarily high quality and/or reliability or a malfunction or failure of which may cause loss of human life or bodily injury ("Unintended Usage"). Unintended Usage include atomic energy control instruments, airplane or spaceship instruments, transportation instruments, traffic signal instruments, combustion control instruments, medical instruments, all types of safety devices, etc.. Unintended Usage of TOSHIBA products listed in this document shall be made at the customer's own risk.
- The products described in this document shall not be used or embedded to any downstream products of which manufacture, use and/or sale are prohibited under any applicable laws and regulations.
- The information contained herein is presented only as a guide for the applications of our products. No responsibility is assumed by TOSHIBA for any infringements of patents or other rights of the third parties which may result from its use. No license is granted by implication or otherwise under any patents or other rights of TOSHIBA or the third parties.
- Please contact your sales representative for product-by-product details in this document regarding RoHS compatibility. Please use these products in this document in compliance with all applicable laws and regulations that regulate the inclusion or use of controlled substances. Toshiba assumes no liability for damage or losses occurring as a result of noncompliance with applicable laws and regulations.