

Adjustable Precision Shunt Regulator

TO-92



Pin Definition:

1. Reference
2. Anode
3. Cathode

SOT-23



Pin Definition:

1. Reference
2. Cathode
3. Anode

SOT-25



Pin Definition:

1. N/C
2. N/C *
3. Cathode
4. Reference
5. Anode

* (pin 2 is connect to substrate and must be connected to Anode or left open)

General Description

The TS432I/432AI/TS432BI is a three-terminal adjustable shunt regulator with specified thermal stability. The output voltage may be set to any value between V_{ref} (approximately 1.24V) and 18V with two external resistors. The TS432I/432AI/TS432BI has a typical output impedance of 0.05Ω. Active output circuitry provides a very sharp turn-on characteristic, making the TS432I/432AI/TS432BI excellent replacement for zener diode in many applications.

Features

- Precision Reference Voltage
 TS432I – 1.24V±2%
 TS432AI – 1.24V±1%
 TS432BI – 1.24V±0.5%
- Minimum Cathode Current for Regulation: 20uA(typ.)
- Equivalent Full Range Temp. Coefficient: 50ppm/ °C
- Programmable Output Voltage up to 18V
- Fast Turn-On Response
- Sink Current Capability of 80uA to 100mA
- Low Dynamic Output Impedance: 0.2Ω
- Low Output Noise

Ordering Information

Part No.	Package	Packing
TS432xIT B0	TO-92	1Kpcs / Bulk
TS432xIT A3	TO-92	2Kpcs / Ammo
TS432xIX RF	SOT-23	3Kpcs / 7" Reel
TS432xIX5 RF	SOT-25	3Kpcs / 7" Reel

Note: Where **xx** denotes voltage tolerance

Blank: ±2%

A: ±1%

B: ±0.5%

Block Diagram

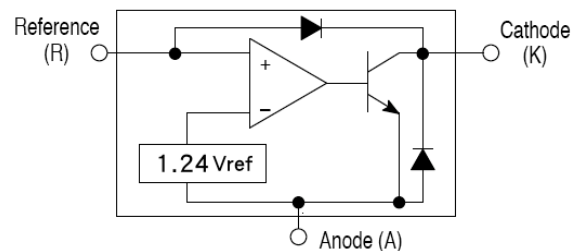

Application

- Voltage Monitor
- Delay Timmer
- Constant –Current Source/Sink
- High-Current Shunt Regulator
- Crow Bar
- Over-Voltage / Under-Voltage Protection

Absolute Maximum Rating (Ta = 25 °C unless otherwise noted)

Parameter	Symbol	Limit	Unit
Cathode Voltage (Note 1)	V_{ka}	18	V
Continuous Cathode Current Range	I_k	100	mA
Reference Input Current Range	I_{ref}	3	mA
Power Dissipation	TO-92	0.625	W
	SOT-23	0.35	
	SOT-25	0.35	
Junction Temperature	T_J	+150	°C
Operation Temperature Range	T_{OPER}	-40 ~ +85	°C
Storage Temperature Range	T_{STG}	-65 ~ +150	°C

Note 1: Voltage values are with respect to the anode terminal unless otherwise noted.

Note 2: Rating apply to ambient temperature at 25°C

Recommend Operating Condition

Parameter	Symbol	Limit	Unit
Cathode Voltage (Note 1)	Vka	18	V
Continuous Cathode Current Range	I _k	100	mA

Recommend Operating Condition

Parameter	Symbo	Test Conditions	Min	Typ	Max	Unit
Reference voltage	TS432I	Vka =Vref, I _k =10mA (Figure 1) Ta=25 °C	1.215	1.240	1.264	V
	TS432AI		1.227		1.252	
	TS432BI		1.233		1.246	
Deviation of reference input voltage	ΔVref	Vka =Vref, I _k =10mA Ta= full range (Figure 1)	--	10	25	mV
Radio of change in Vref to change in cathode Voltage	ΔVref/ΔVka	I _{ka} =10mA, Vka = 18V to Vref (Figure 2)	--	-1.0	-2.7	mV/V
Reference Input current	Iref	R1=10KΩ, R2= ∞ , I _{ka} =10mA Ta= full range (Figure 2)	--	0.25	0.5	uA
Deviation of reference input current, over temp.	ΔIref	R1=10KΩ, R2= ∞ , I _{ka} =10mA Ta= full range (Figure 2)	--	0.04	0.08	uA
Off-state Cathode Current	I _{ka(off)}	Vref=0V (Figure 3), Vka=18V	--	0.125	0.5	uA
Dynamic Output Impedance	Z _{ka}	f<1KHz, Vka=Vref I _{ka} =1mA to 100mA (Figure 1)	--	0.2	0.4	Ω
Minimum operating cathode current	I _{ka(min)}	Vka=Vref (Figure 1)	--	60	80	uA

* The deviation parameters ΔVref and ΔIref are defined as difference between the maximum value and minimum value obtained over the full operating ambient temperature range that applied.

* The average temperature coefficient of the reference input voltage, αVref is defined as:

$$\alpha V_{ref} \left(\frac{\text{ppm}}{^{\circ}\text{C}} \right) = \frac{\left(\frac{\Delta V_{ref}}{V_{ref} (T_A = 25^{\circ}\text{C})} \times 10^6 \right)}{\Delta T_A}$$

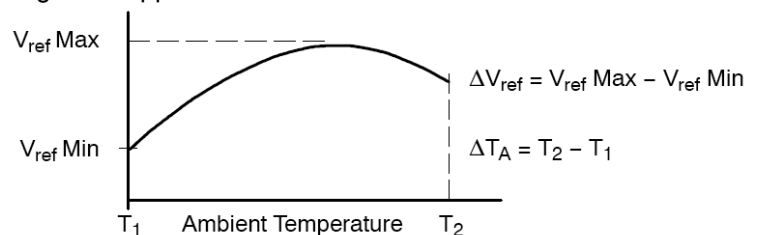

Where: **T2-T1** = full temperature change.

αVref can be positive or negative depending on whether Vref Min. or Vref Max occurs at the lower ambient temperature. Example: ΔVref=7.2mV and the slope is positive, Vref=1.241V at 25°C, ΔT=125 °C

$$\alpha V_{ref} \left(\frac{\text{ppm}}{^{\circ}\text{C}} \right) = \frac{\frac{0.0072}{1.241} \times 10^6}{125} = 46 \text{ ppm}/^{\circ}\text{C}$$

* The dynamic impedance ZKA is defined as:

$$|Z_{KA}| = \frac{\Delta V_{KA}}{\Delta I_K}$$

* When the device operating with two external resistors, R1 and R2, (refer to Figure 2) the total dynamic impedance of the circuit is given by:

$$|Z_{KA}'| = |Z_{KA}| \times \left(1 + \frac{R1}{R2} \right)$$

Test Circuits

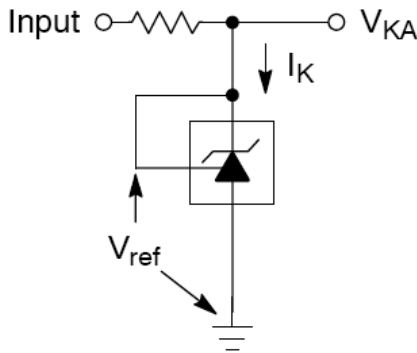

Figure 1: $V_{ka} = V_{ref}$

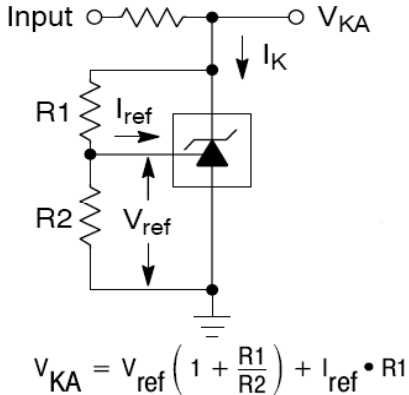

Figure 2: $V_{ka} > V_{ref}$

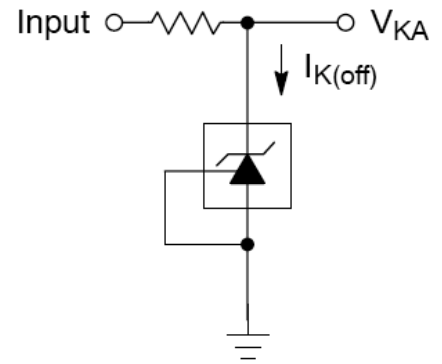

Figure 3: Off-State Current

Additional Information – Stability

When The TS4321/432A1/432B1 is used as a shunt regulator, there are two options for selection of C_L , are recommended for optional stability:

- A) No load capacitance across the device, decouple at the load.
- B) Large capacitance across the device, optional decoupling at the load.

The reason for this is that TS4321/432A1/432B1 exhibits instability with capacitances in the range of 10nF to 1uF (approx.) at light cathode current up to 3mA (typ). The device is less stable the lower the cathode voltage has been set for. Therefore while the device will be perfectly stable operating at a cathode current of 10mA (approx.) with a 0.1uF capacitor across it, it will oscillate transiently during start up as the cathode current passes through the instability region. Select a very low capacitance, or alternatively a high capacitance (10uF) will avoid this issue altogether. Since the user will probably wish to have local decoupling at the load anyway, the most cost effective method is to use no capacitance at all directly across the device. PCB trace/via resistance and inductance prevent the local load decoupling from causing the oscillation during the transient start up phase.

Note: if the TS4321/432A1/432B1 is located right at the load, so the load decoupling capacitor is directly across it, then this capacitor will have to be $\leq 1nF$ or $\geq 10uF$.

Applications Examples

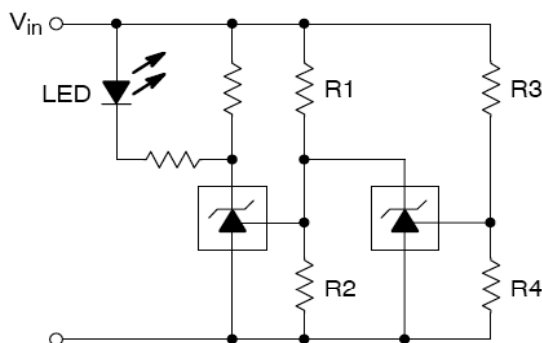

L.E.D. indicator is 'ON' when V_{in} is between the upper and lower limits,

$$\text{Lower limit} = \left(1 + \frac{R1}{R2} \right) V_{ref}$$

$$\text{Upper limit} = \left(1 + \frac{R3}{R4} \right) V_{ref}$$

Figure 4: Voltage Monitor

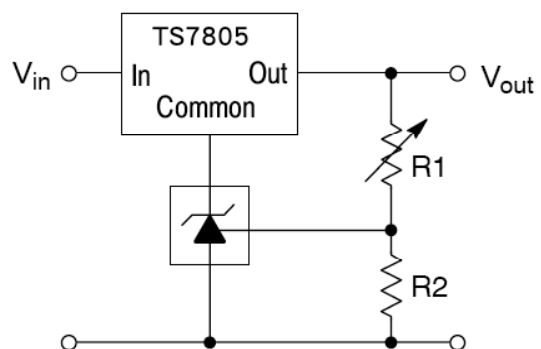

$$V_{out} = \left(1 + \frac{R1}{R2} \right) V_{ref}$$

$$V_{out(min)} = V_{ref} + 5.0 \text{ V}$$

Figure 5: Output Control for Three Terminal Fixed Regulator

Applications Examples (Continue)

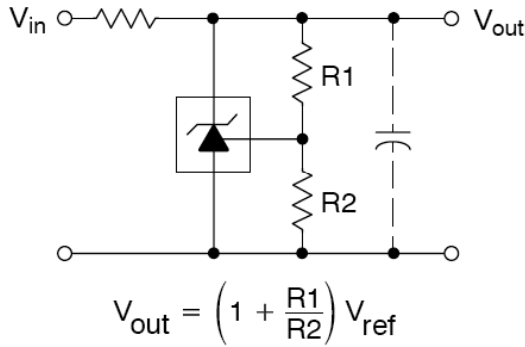

Figure 6: Shunt Regulator

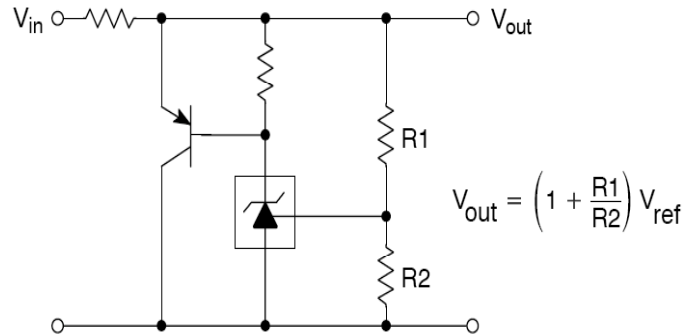

Figure 7: High Current Shunt Regulator

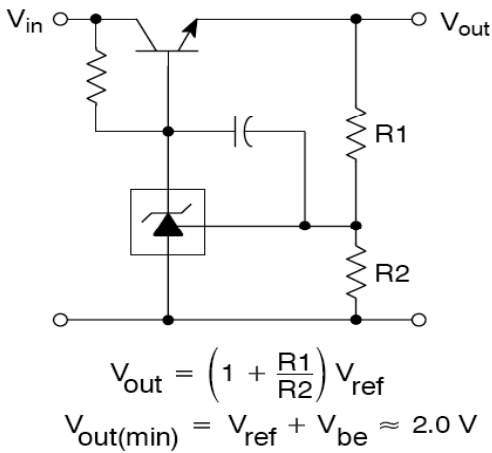

Figure 8: Series Pass Regulator

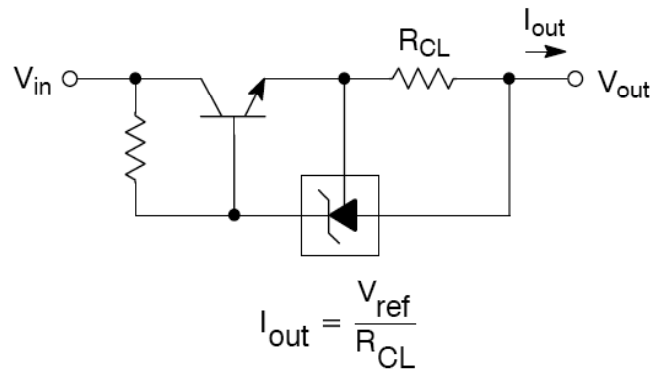

Figure 9: Constant Current Source

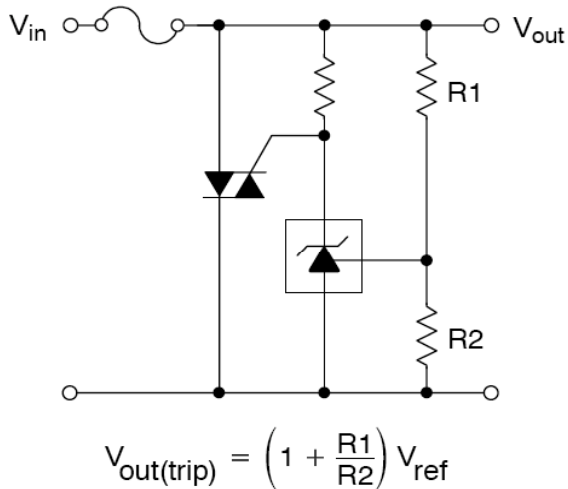

Figure 10: TRIAC Crowbar

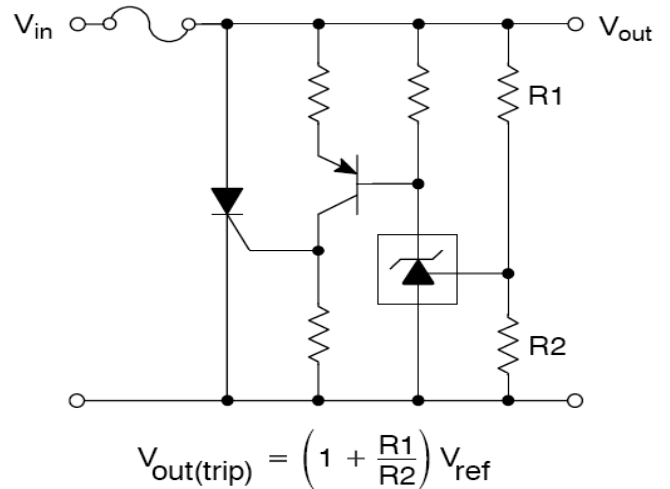
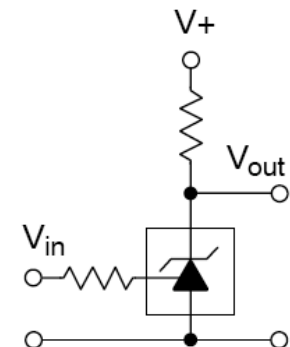

Figure 11: SCR Crowbar

Applications Examples (Continue)



V _{in}	V _{out}
<V _{ref}	V+
>V _{ref}	≈0.74V

Figure 12: Single-Supply Comparator with Temperature-Compensated Threshold

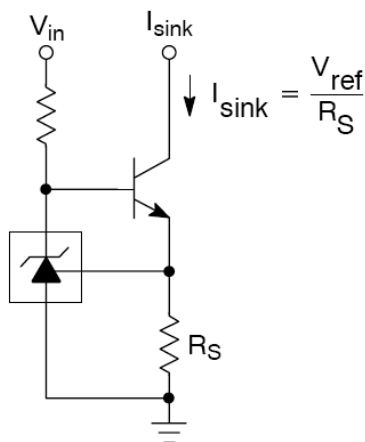
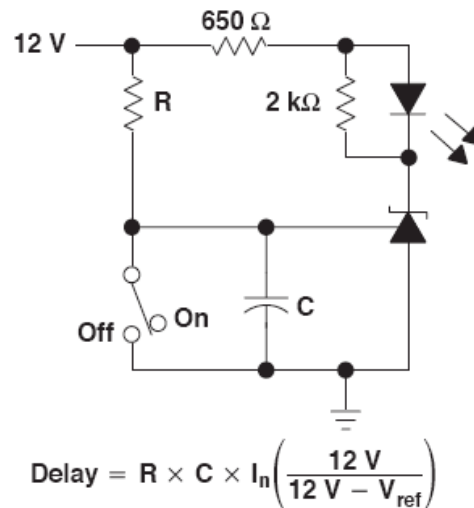

Figure 13: Constant Current Sink



$$\text{Delay} = R \times C \times I_n \left(\frac{12 \text{ V}}{12 \text{ V} - V_{\text{ref}}} \right)$$

Figure 14: Delay Timer

Typical Performance Characteristics

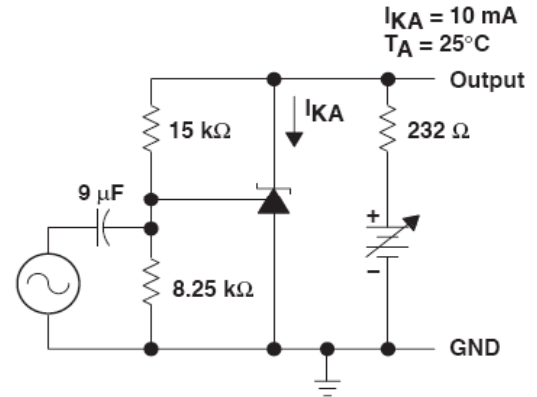
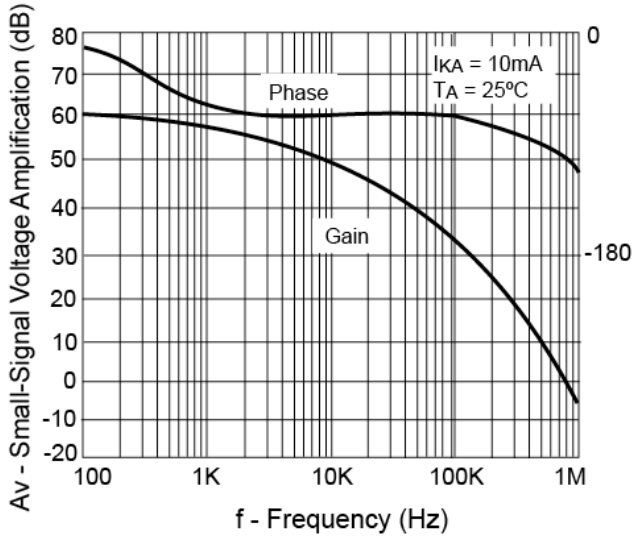

Test Circuit for Voltage Amplification

Figure 14: Small-Signal Voltage Gain and Phase Shift vs. Frequency

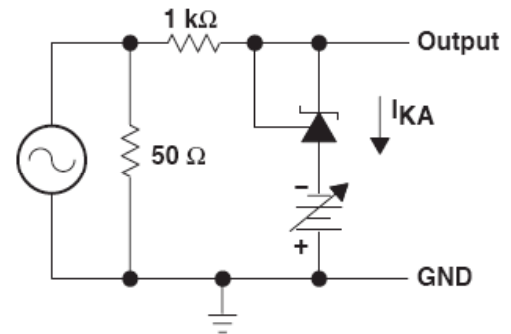
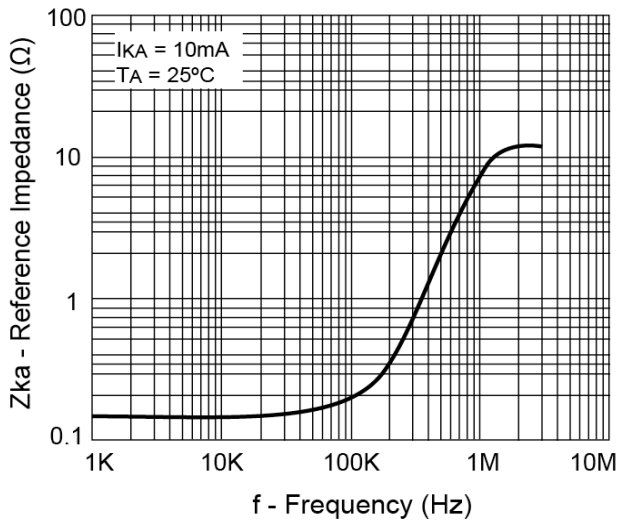

Test Circuit for Reference Impedance

Figure 15: Reference Impedance vs. Frequency

Typical Performance Characteristics

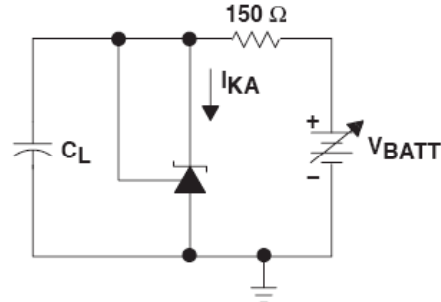
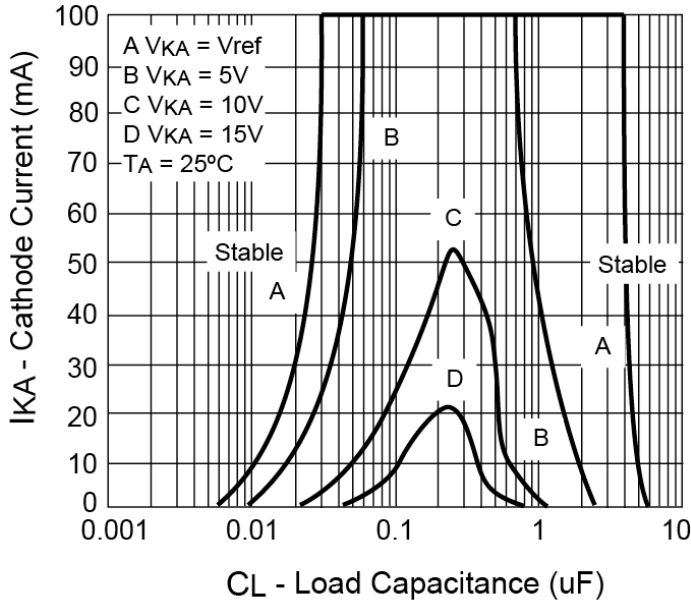

Test Circuit for Curve A

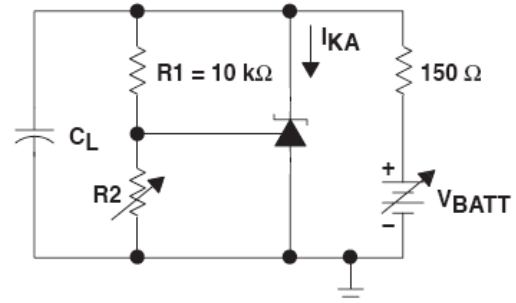

Test Circuit for Curve B, C and D

The areas under the curves represent conditions that may cause the device to oscillate. For curves B, C, and D, R_2 and V_+ were adjusted to establish the initial V_{KA} and I_{KA} conditions with $C_L=0$. V_{BATT} and C_L then were adjusted to determine the ranges of stability.

Figure 16: Stability Boundary Condition

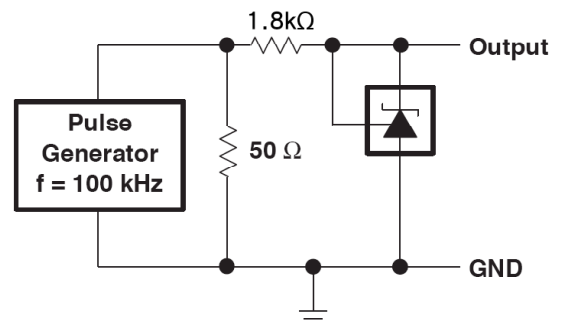
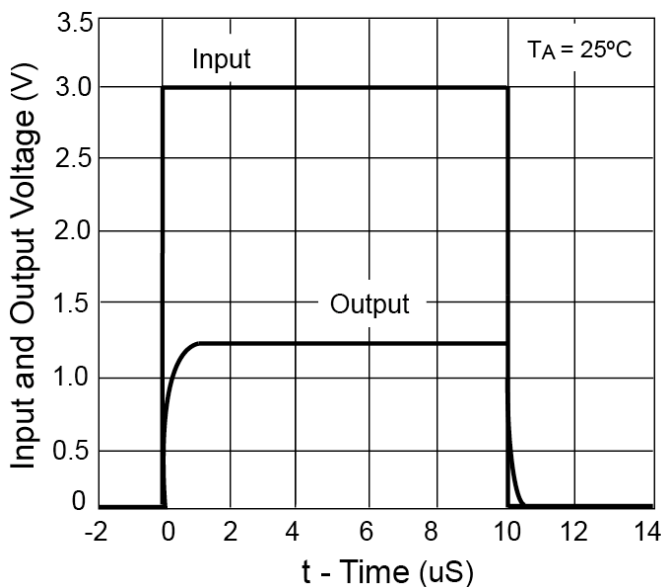

Test Circuit for Pulse Response, $I_{K1}=1mA$

Figure 17: Pulse Response

Electrical Characteristics

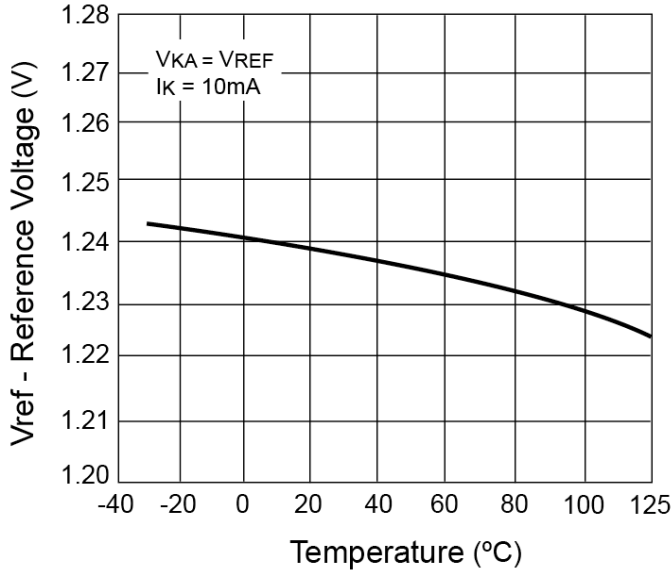

Figure 18: Reference Voltage vs. Temperature

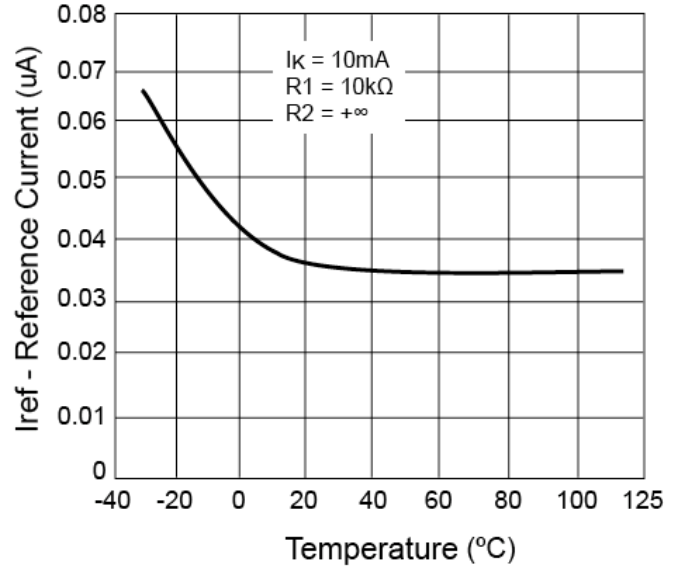

Figure 19: Reference Current vs. Temperature

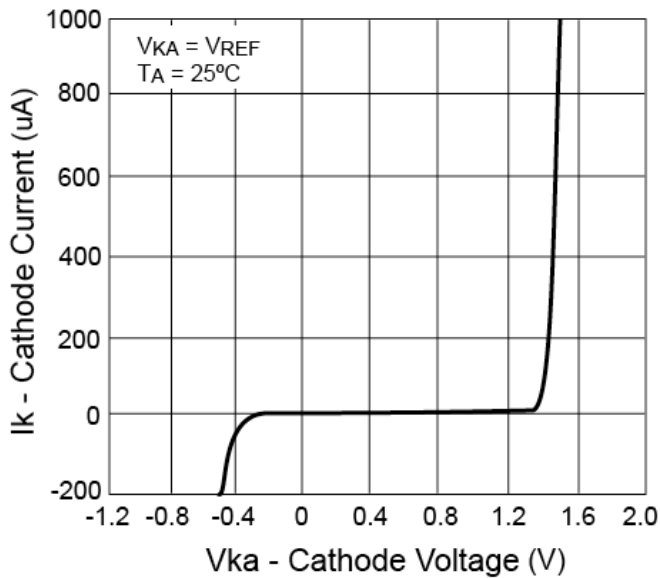
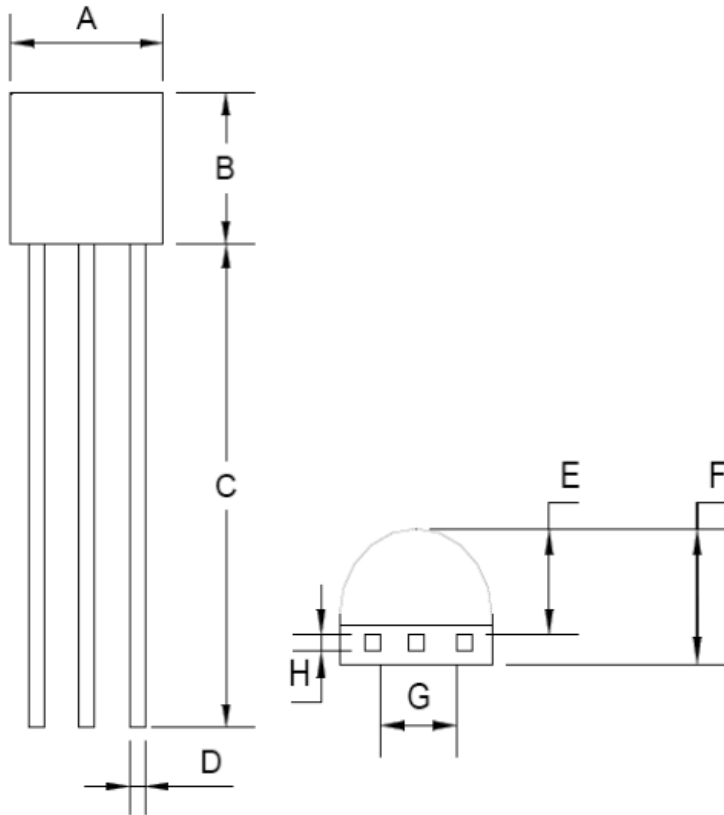

Figure 20: Cathode Current vs. Cathode Voltage

TO-92 Mechanical Drawing



TO-92 DIMENSION				
DIM	MILLIMETERS		INCHES	
	MIN	MAX	MIN	MAX
A	4.30	4.70	0.169	0.185
B	4.30	4.70	0.169	0.185
C	14.30(typ)		0.563(typ)	
D	0.43	0.49	0.017	0.019
E	2.19	2.81	0.086	0.111
F	3.30	3.70	0.130	0.146
G	2.42	2.66	0.095	0.105
H	0.37	0.43	0.015	0.017

Marking Diagram

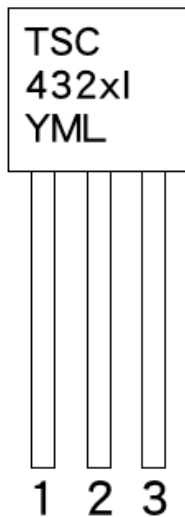

- X** = Tolerance Code
(**A** = ±1%, **B** = ±0.5%, **Blank** = ±2%.)
- Y** = Year Code
- M** = Month Code
(**A**=Jan, **B**=Feb, **C**=Mar, **D**=Apr, **E**=May, **F**=Jun, **G**=Jul, **H**=Aug, **I**=Sep, **J**=Oct, **K**=Nov, **L**=Dec)
- L** = Lot Code

SOT-23 Mechanical Drawing

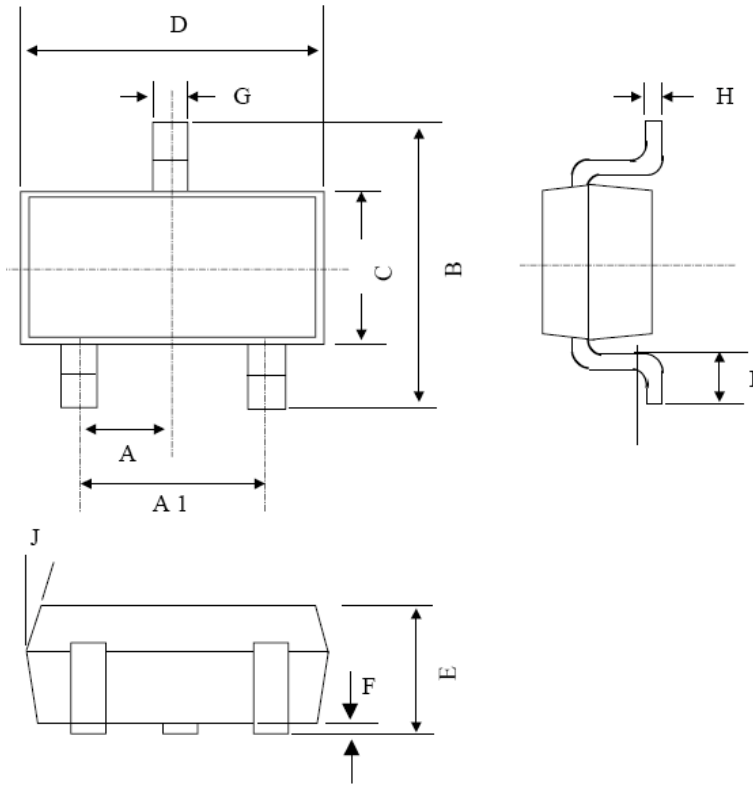

DIM	MILLIMETERS		INCHES	
	MIN	MAX	MIN	MAX.
A	0.95 BSC		0.037 BSC	
A1	1.9 BSC		0.074 BSC	
B	2.60	3.00	0.102	0.118
C	1.40	1.70	0.055	0.067
D	2.80	3.10	0.110	0.122
E	1.00	1.30	0.039	0.051
F	0.00	0.10	0.000	0.004
G	0.35	0.50	0.014	0.020
H	0.10	0.20	0.004	0.008
I	0.30	0.60	0.012	0.024
J	5°	10°	5°	10°

Marking Diagram

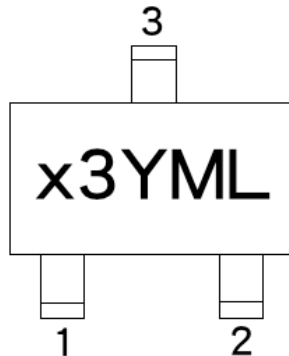

- X** = Device Code
(D = TS432AI, E = TS432BI, F = TS432I,)
- 3** = SOT-23 package
- Y** = Year Code
- M** = Month Code
(A=Jan, B=Feb, C=Mar, D=Apl, E=May, F=Jun, G=Jul, H=Aug, I=Sep, J=Oct, K=Nov, L=Dec)
- L** = Lot Code

SOT-25 Mechanical Drawing

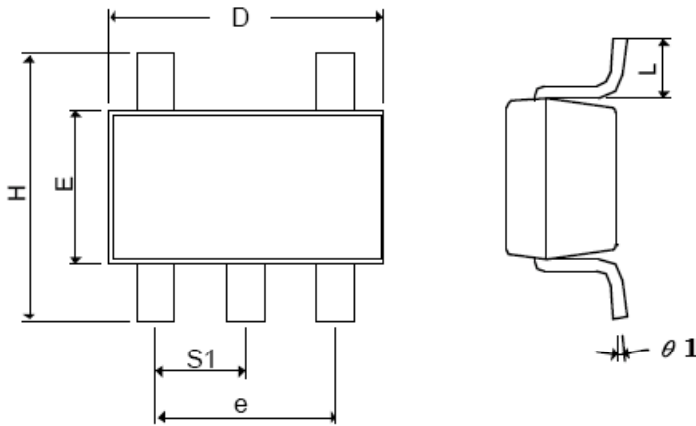

SOT-25 DIMENSION				
DIM	MILLIMETERS		INCHES	
	MIN	MAX	MIN	MAX
A+A1	0.09	1.25	0.0354	0.0492
B	0.30	0.50	0.0118	0.0197
C	0.09	0.25	0.0035	0.0098
D	2.70	3.10	0.1063	0.1220
E	1.40	1.80	0.0551	0.0709
E	1.90 BSC		0.0748 BSC	
H	2.40	3.00	0.09449	0.1181
L	0.35 BSC		0.0138 BSC	
$\theta 1$	0°	10°	0°	10°
S1	0.95 BSC		0.0374 BSC	

Front View

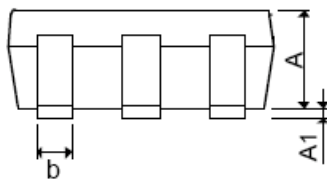

Marking Diagram

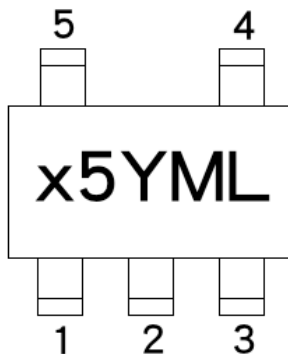

- X** = Device Code
(**D** = TS432AI, **E** = TS432BI, **F** = TS432I,)
- 5** = SOT-25 package
- Y** = Year Code
- M** = Month Code
(**A**=Jan, **B**=Feb, **C**=Mar, **D**=Apr, **E**=May, **F**=Jun, **G**=Jul, **H**=Aug, **I**=Sep, **J**=Oct, **K**=Nov, **L**=Dec)
- L** = Lot Code

Notice

Specifications of the products displayed herein are subject to change without notice. TSC or anyone on its behalf, assumes no responsibility or liability for any errors or inaccuracies.

Information contained herein is intended to provide a product description only. No license, express or implied, to any intellectual property rights is granted by this document. Except as provided in TSC's terms and conditions of sale for such products, TSC assumes no liability whatsoever, and disclaims any express or implied warranty, relating to sale and/or use of TSC products including liability or warranties relating to fitness for a particular purpose, merchantability, or infringement of any patent, copyright, or other intellectual property right.

The products shown herein are not designed for use in medical, life-saving, or life-sustaining applications. Customers using or selling these products for use in such applications do so at their own risk and agree to fully indemnify TSC for any damages resulting from such improper use or sale.