

Six Channel Integrated Power Management IC for Handheld Portable Equipment

FEATURES

- Multiple Patents Pending
- Li+ Battery Charger with Integrated MOSFET
 - Auto-Select Charge Current (AC or USB)
 - ON/OFF Control and Status Indication
- Five Integrated Regulators
 - 350mA PWM Step-Down DC/DC
 - 550mA PWM Step-Down DC/DC
 - 250mA High PSRR LDO
 - 250mA High PSRR LDO
 - 250mA High PSRR LDO
- Minimal External Components
- 4x4mm, Thin-QFN (TQFN44-24) Package
 - Only 0.75mm Height
 - RoHS Compliant

APPLICATIONS

- Portable Devices and PDAs
- Digital Media Players
- Battery Operated Devices
- GPS Receivers, etc.

GENERAL DESCRIPTION

The patent-pending ACT8770 is a complete, cost-effective, highly efficient *ActivePMU™* integrated power management solution that is ideal for a wide range of portable handheld equipment. This device integrates two PWM step-down DC/DC converters, three low dropout linear regulators (LDOs) and a full-featured linear-mode Li+ battery charger into a single, thin, space-saving package.

REG1 and REG2 are fixed-frequency, current-mode PWM step-down DC/DC converters that are optimized for high efficiency and are capable of supplying to 350mA and 550mA, respectively. The three LDOs are high PSRR linear regulators, each capable of supplying up to 250mA. The battery charger incorporates an internal power MOSFET for constant-current/constant-voltage, thermally regulated charging of a single-cell Li+ battery.

The ACT8770 is available in a tiny 4mm x 4mm 24-pin Thin-QFN package that is just 0.75mm thin.

SYSTEM BLOCK DIAGRAM

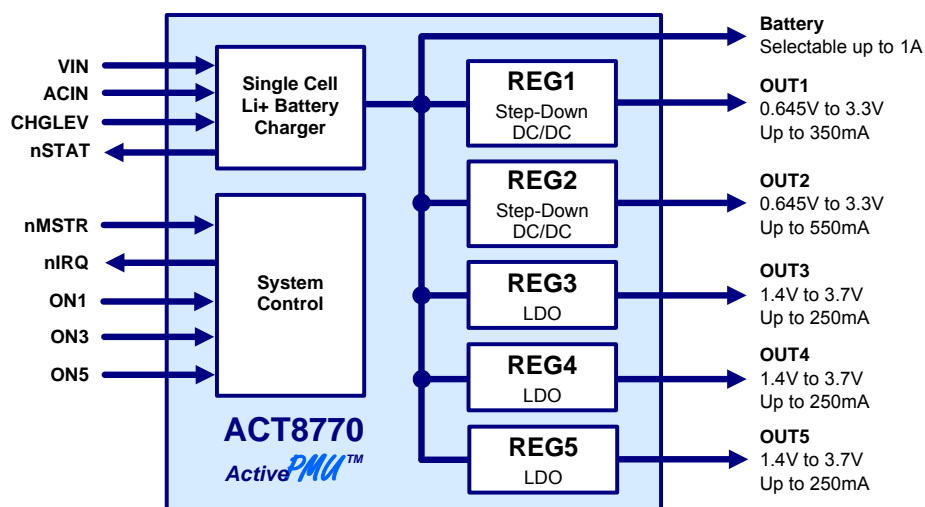

PRODUCT OPTIONS

Block	Function	Output Voltage ^①	Capability ^②
CHGR	Battery Charger	4.20V (4.10V to 4.30V available)	Selectable up to 1A
REG1	Step-Down DC/DC	0.645V to 3.3V	350mA
REG2	Step-Down DC/DC		550mA
REG3	LDO	1.4V to 3.7V	250mA
REG4	LDO		250mA
REG5	LDO		250mA

①: Output voltage options detailed in this table represent standard voltage options, and are available for samples or production orders.. Contact Active-Semi for more information regarding semi-custom output voltage combinations.

②: Contact factory for additional available products or custom requirements.

FUNCTIONAL BLOCK DIAGRAM

