

### FEATURES

- Low noise density, 0.0125°/sec/√Hz
- Industry-standard serial peripheral interface (SPI)
- 24-bit digital resolution
- ±250°/sec dynamic range
- Z-axis, yaw rate response
- 300 Hz bandwidth, adjustable
- 35 ms turn-on time
- Digital self-test
- High vibration rejection
- High shock survivability
- Embedded temperature sensor output
- Precision voltage reference output
- 5 V single-supply operation
- −40°C to +85°C

### APPLICATIONS

- Guidance and control
- Instrumentation
- Inertial measurement units (IMU)
- Platform stabilization
- Navigation

### GENERAL DESCRIPTION

The ADIS16130 is a low noise, digital output angular rate sensor (gyroscope) that provides an output response over the complete dynamic range of ±250°/sec.

Its industry-standard serial interface and register structure provide a simple interface that is supported by most MCU, DSP, and FPGA platforms.

By implementing a unique design, the device provides superior stability over variations in temperature, voltage, linear acceleration, vibration, and next-level assembly. In addition, the surface-micro-machining technology used to manufacture the device is the same high volume BiMOS process used by Analog Devices, Inc., for its high reliability automotive sensor products.

Features include a temperature output that provides critical information for system-level calibrations, and a digital self-test feature, which exercises the mechanical structure of the sensor and enables system-level diagnostics.

The package configuration is a 36 mm × 44 mm × 16 mm module with a standard 24-lead connector interface.

### FUNCTIONAL BLOCK DIAGRAM

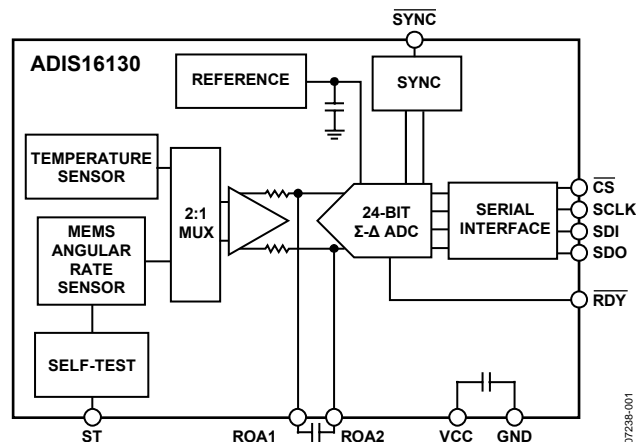

Figure 1.

#### Rev. 0

Information furnished by Analog Devices is believed to be accurate and reliable. However, no responsibility is assumed by Analog Devices for its use, nor for any infringements of patents or other rights of third parties that may result from its use. Specifications subject to change without notice. No license is granted by implication or otherwise under any patent or patent rights of Analog Devices. Trademarks and registered trademarks are the property of their respective owners.

## TABLE OF CONTENTS

Features .....	1	Typical Performance Characteristics .....	8
Applications .....	1	Basic Operation .....	9
General Description .....	1	Getting Started Quickly .....	9
Functional Block Diagram .....	1	Configuration Options .....	10
Revision History .....	2	Control Registers .....	11
Specifications .....	3	Control Register Details .....	11
Timing Specifications .....	4	Applications Information .....	12
Absolute Maximum Ratings .....	6	Achieving Optimal Noise Performance .....	12
Thermal Resistance .....	6	Second-Level Assembly .....	12
ESD Caution .....	6	Outline Dimensions .....	13
Pin Configuration and Function Descriptions .....	7	Ordering Guide .....	13

## REVISION HISTORY

1/08—Revision 0: Initial Version

## SPECIFICATIONS

$T_A = 25^\circ\text{C}$ ,  $V_{CC} = 5\text{ V}$ , angular rate =  $0^\circ/\text{sec}$ ,  $C_{OUT} = 0\ \mu\text{F}$ ,  $\pm 1\text{ g}$ , unless otherwise noted.

Table 1.

Parameter	Conditions	Min <sup>1</sup>	Typ	Max	Unit
<b>SENSITIVITY</b>					
Dynamic Range <sup>2</sup>	Clockwise rotation is positive output (See Figure 5) Full-scale range over specified operating conditions	$\pm 250$			$^\circ/\text{sec}$
Initial		22,548	23,488	24,428	LSB/ $^\circ/\text{sec}$
Nonlinearity	Best fit straight line		0.04		% of FS
<b>NULL</b>					
Initial Null	$\pm 1\sigma$		$\pm 3$		$^\circ/\text{sec}$
In-Run Bias Stability	$1\sigma$		0.0016		$^\circ/\text{sec}$
Angle Random Walk	$1\sigma$		0.56		$^\circ/\sqrt{\text{hr}}$
Turn-On Time	Power on to $\pm 0.5^\circ/\text{sec}$ of final value, 80 Hz bandwidth		35		ms
Linear Acceleration Effect	Any axis		0.05		$^\circ/\text{sec}/\text{g}$
Voltage Sensitivity	$V_{CC} = 4.75\text{ V to } 5.25\text{ V}$		0.2		$^\circ/\text{sec}/\text{V}$
<b>NOISE PERFORMANCE</b>					
Rate Noise Density <sup>3</sup>			0.0125		$^\circ/\text{sec}/\sqrt{\text{Hz}}$
<b>FREQUENCY RESPONSE</b>					
Bandwidth	$-3\text{ dB}$ frequency with no external capacitance		300		Hz
Sensor Resonant Frequency			14		kHz
<b>SELF-TEST INPUTS</b>					
ST RATEOUT Response <sup>4</sup>	ST pins from Logic 0 to Logic 1	65	75	85	$^\circ/\text{sec}$
Logic 1 Input Voltage	Standard high logic level definition	3.3			V
Logic 0 Input Voltage	Standard low logic level definition			1.7	V
Input Impedance	To GND		3.13		k $\Omega$
<b>TEMPERATURE SENSOR</b>					
Output at 298 K (25 $^\circ\text{C}$ )			8,388,608		LSB
Scale Factor			14,093		LSB/ $^\circ\text{C}$
<b>DIGITAL OUTPUTS</b>					
Output Low Voltage ( $V_{OL}$ )				0.4	V
Output High Voltage ( $V_{OH}$ )		4			V
<b>DIGITAL INPUTS</b>					
Input Current	$\overline{\text{CS}}$ All others			10	$\mu\text{A}$
Input Capacitance			5	1	$\mu\text{A}$
VT+		1.4		2	pF
VT-		0.8		1.4	V
(VT+) - (VT-)		0.3		0.85	V
<b>POWER SUPPLY</b>					
Operating Voltage Range		4.75	5.00	5.25	V
Quiescent Supply Current	$I_{OUT} = 0\text{ mA}$ , 5 V		73	85	mA
<b>TEMPERATURE RANGE</b>					
Operating Range		-40		+85	$^\circ\text{C}$

<sup>1</sup> All minimum and maximum specifications are guaranteed. Typical specifications are not tested or guaranteed.

<sup>2</sup> Dynamic range is the maximum full-scale measurement range possible, including output swing range, initial offset, sensitivity, offset drift, and sensitivity drift at 4.75 V to 5.25 V supplies.

<sup>3</sup> Resulting bias stability is  $<0.01^\circ/\text{sec}$ .

<sup>4</sup> Self-test response varies with temperature, see Figure 12.

# ADIS16130

## TIMING SPECIFICATIONS

All input signals are specified with 10% to 90% rise and fall times of less than 5 ns.

Table 2.

Parameter	Min	Typ	Max	Unit	Test Conditions/Comments
t <sub>1</sub>	50			ns	$\overline{\text{SYNC}}$ pulse width
Read Operation					
t <sub>4</sub>	0			ns	$\overline{\text{CS}}$ falling edge to SCLK falling edge setup time
t <sub>5</sub> <sup>1</sup>					SCLK falling edge to data valid delay
	0		60	ns	DV <sub>DD</sub> of 4.75 V to 5.25 V
t <sub>5A</sub> <sup>1,2</sup>					$\overline{\text{CS}}$ falling edge to data valid delay
	0		60	ns	DV <sub>DD</sub> of 4.75 V to 5.25 V
t <sub>6</sub>	50			ns	SCLK high pulse width
t <sub>7</sub>	50			ns	SCLK low pulse width
t <sub>8</sub>	0			ns	$\overline{\text{CS}}$ rising edge after SCLK rising edge hold time
t <sub>9</sub> <sup>3</sup>	10		80	ns	Bus relinquish time after SCLK rising edge
Write Operation					
t <sub>11</sub>	0			ns	$\overline{\text{CS}}$ falling edge to SCLK falling edge setup
t <sub>12</sub>	30			ns	Data valid to SCLK rising edge setup time
t <sub>13</sub>	25			ns	Data valid after SCLK rising edge hold time
t <sub>14</sub>	50			ns	SCLK high pulse width
t <sub>15</sub>	50			ns	SCLK low pulse width
t <sub>16</sub>	0			ns	$\overline{\text{CS}}$ rising edge after SCLK rising edge hold time

<sup>1</sup> These numbers are measured with the load circuit shown in Figure 4 and defined as the time required for the output to cross the V<sub>OL</sub> or V<sub>OH</sub> limits.

<sup>2</sup> This specification is relevant only if  $\overline{\text{CS}}$  goes low while SCLK is low.

<sup>3</sup> These numbers are derived from the measured time taken by the data output to change 0.5 V when loaded with the circuit shown in Figure 4. The measured number is then extrapolated back to remove effects of charging or discharging the 50 pF capacitor. Therefore, the times quoted are the true bus relinquish times of the part and as such are independent of external bus loading capacitances.

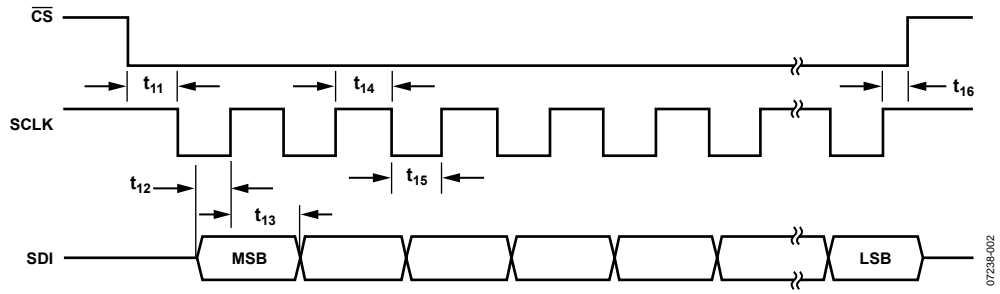

Figure 2. Input Timing for Write Operation

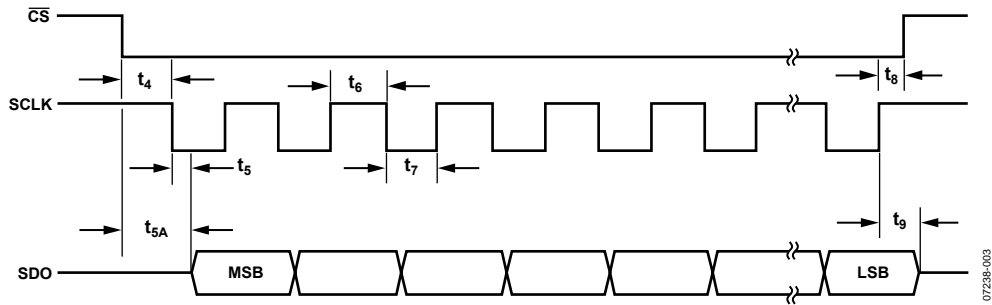

Figure 3. Output Timing for Read Operation

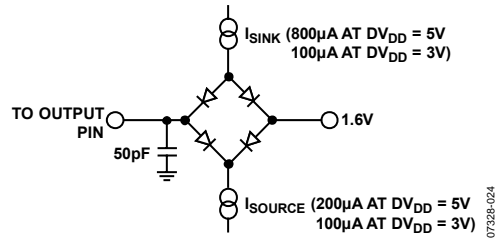

Figure 4. Load Circuit for Access Time and Bus Relinquish Time

# ADIS16130

## ABSOLUTE MAXIMUM RATINGS

Table 3.

Parameter	Rating
Acceleration (Any Axis, Unpowered, 0.5 ms)	2000 g
Acceleration (Any Axis, Powered, 0.5 ms)	2000 g
+Vs	-0.3 V to +6.0 V
Output Short-Circuit Duration (Any Pin to Common)	Indefinite
Operating Temperature Range	-40°C to +85°C
Storage Temperature Range	-65°C to +150°C

Stresses above those listed under Absolute Maximum Ratings may cause permanent damage to the device. This is a stress rating only; functional operation of the device at these or any other conditions above those indicated in the operational section of this specification is not implied. Exposure to absolute maximum rating conditions for extended periods may affect device reliability.

Dropping the device onto a hard surface may cause a shock of greater than 2000 g and exceed the absolute maximum rating of the device. Care should be exercised when handling the device to avoid damage.

## THERMAL RESISTANCE

The ADIS16130 provides a temperature output that is representative of the junction temperature. This can be used for system-level monitoring and power management/thermal characterization.

Table 4. Thermal Characteristics

Package Type <sup>1</sup>	$\theta_{JA}$	$\theta_{JC}$	Unit
24-Lead Module	15.7	1.48	°C/W

<sup>1</sup> Weight = 28.5 g typical.

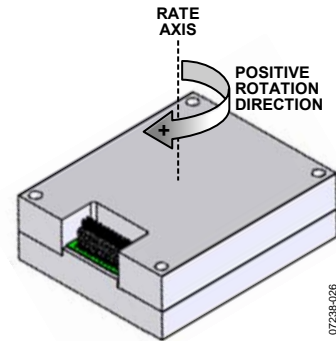

Figure 5. Rotational Measurement Orientation

## ESD CAUTION



**ESD (electrostatic discharge) sensitive device.** Charged devices and circuit boards can discharge without detection. Although this product features patented or proprietary protection circuitry, damage may occur on devices subjected to high energy ESD. Therefore, proper ESD precautions should be taken to avoid performance degradation or loss of functionality.

## PIN CONFIGURATION AND FUNCTION DESCRIPTIONS

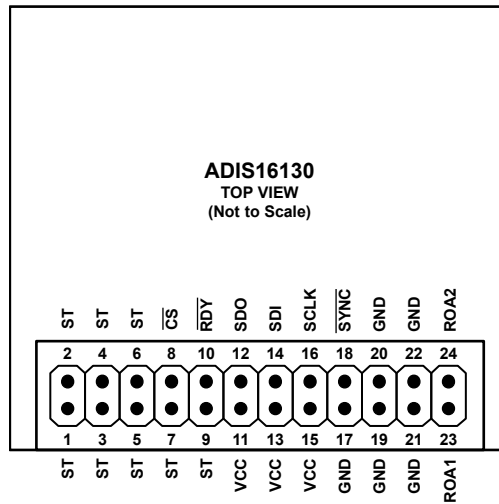

Figure 6. Pin Configuration, Top View

Table 5. Pin Function Descriptions

Pin No.	Mnemonic	Description
1 to 7, 9	ST	Self-Test (see the Self-Test Function section)
8	$\overline{CS}$	Chip Select of the SPI
10	$\overline{RDY}$	Data Ready
11, 13, 15	VCC	Power Supply
12	SDO	Data Output of the SPI
14	SDI	Data Input of the SPI
16	SCLK	Serial Clock of the SPI
17, 19 to 22	GND	Power Supply Ground
18	$\overline{SYNC}$	Synchronization Input
23	ROA1	Analog Filter Node 1
24	ROA2	Analog Filter Node 2

## TYPICAL PERFORMANCE CHARACTERISTICS

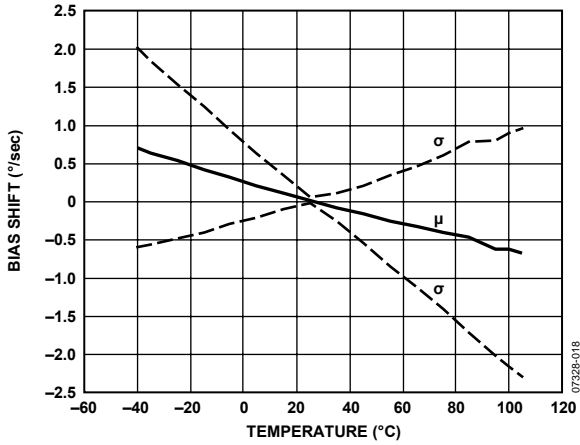

Figure 7. Bias Shift vs. Temperature, VCC = 5 V

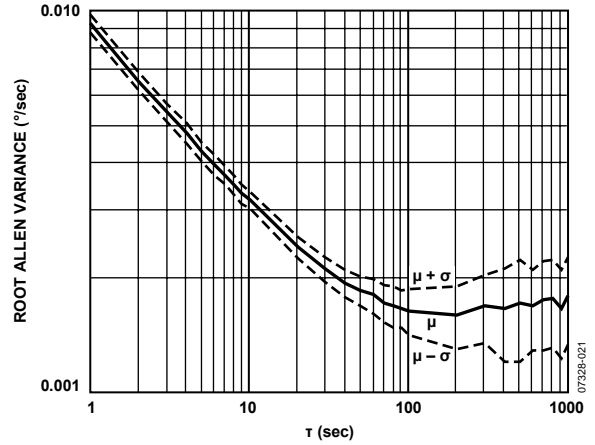

Figure 10. Root Allen Variance, VCC = 5 V, 25°C

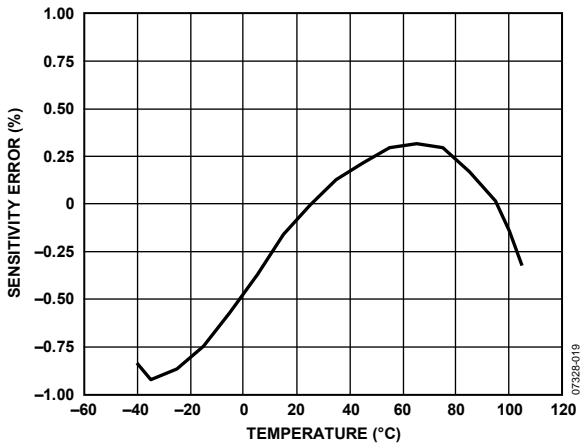

Figure 8. Sensitivity Error vs. Temperature, VCC = 5 V

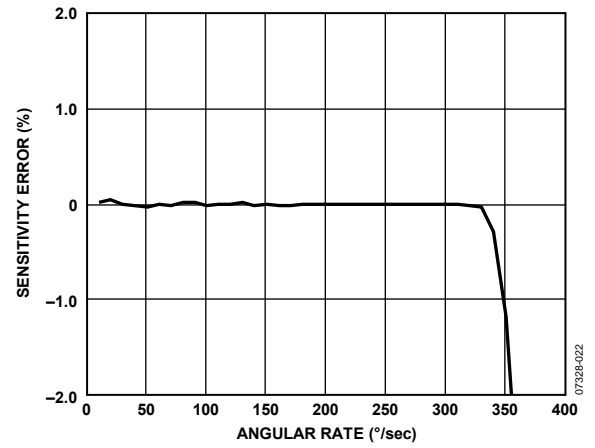

Figure 11. Sensitivity Error vs. Angular Rate, VCC = 5 V, 25°C

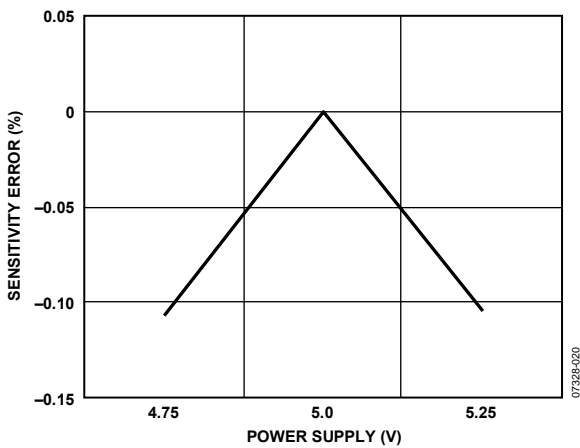

Figure 9. Sensitivity Error vs. Power Supply, 25°C

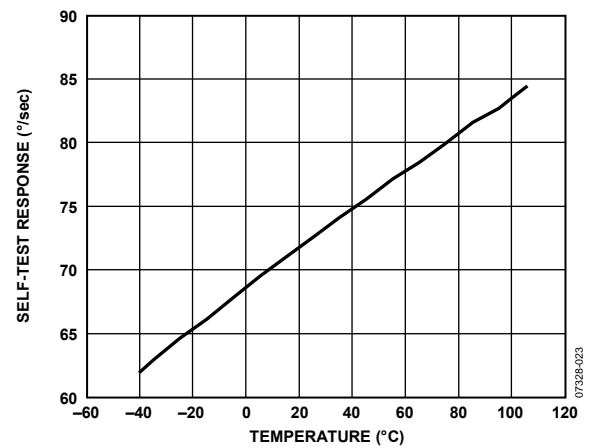

Figure 12. Self-Test Response vs. Temperature, VCC = 5 V



## BASIC OPERATION

The ADIS16130 produces digital angular rate (RATE) and temperature (TEMP) data. The digital communication employs a simple 4-wire SPI, which provides access to output data and several configuration features. A set of communication and configuration registers govern the operation in the ADIS16130. See Table 8 for a summary of these registers.

### GETTING STARTED QUICKLY

The ADIS16130 SPI operates in 8-bit segments. The first byte of a SPI sequence goes into the COM register, which contains the read/write control bit and the address of the target register. When writing information into control registers, the next byte contains the configuration information. When reading output data, the next one to three bytes contain the contents of the register selected.

#### Configuration Sequence

The sequence in Table 6 provides the recommended configuration sequence. Table 2 and Figure 2 provide the timing information for each segment of this configuration sequence.

**Table 6. Configuration Sequence**

Step	SDI <sup>1</sup>	Register	Purpose
1	0x01	COM	Start a write sequence for IOP.
2	0x38	IOP	Configure the data-ready signal to pulse low when the RATEDATA and TEMPDATA output registers contain new data. The data-ready signal goes high after reading either of these registers.
3	0x28	COM	Start a write sequence for the RATECS register.
4	0x0A	RATECS	Enable and configure the gyroscope data channel.
5	0x30	COM	Start a write sequence for RATECONV register.
6	0x05	RATECONV	Initialize the RATE conversion.
7	0x2A	COM	Start a write sequence for the TEMPCS register.
8	0x0A	TEMPCS	Enable and configure the temperature data channel.
9	0x32	COM	Start a write sequence for TEMPCONV.
10	0x05	TEMPCONV	Initialize the TEMP conversion.
11	0x38	COM	Start a write sequence for the MODE register.
12	0x22	MODE	Establish the data output resolution to 24 bits and start the conversion process with the RATEDATA channel.

<sup>1</sup>The SDI column lists the hexadecimal code representation of the SDI bit input sequence.

#### Reading RATE Output Data

After the configuration sequence in Table 6 is complete, reading the output data is very simple. The ADIS16130 converts the RATE and TEMP data continuously. To better understand this process,

Figure 13 provides an example read sequence, and Table 2 and Figure 3 provide critical timing details for the output signal.

The first byte of the sequence uses SDI to establish a read of the RATE output register. This is accomplished by writing 0x48 to the COM register.

The most significant byte is first in the SDO sequence, followed by the next significant, and then the least significant. When 16-bit resolution is in use, only two bytes are output from the SDO during the read sequence.

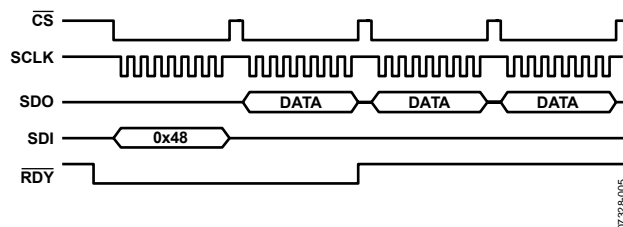

Figure 13. Read Sequence Example

The data-ready signal,  $\overline{\text{RDY}}$ , indicates that unread data is available on both RATE and TEMP output registers. After the RATE or TEMP channel is read, the signal returns high, as shown in Figure 13. The RATE and TEMP channels update sequentially, and each has a sample rate of 5.7 kSPS. The internal sample rate is not dependent on the SPI signals or read rates. Using the data-ready signal to drive data collection helps avoid losing data due to data collision, which is when a user-driven read cycle coincides with the internal update time. In this case, the old data remains and the new data is lost.

If a lower sample rate meets system-level requirements, the data-ready signal can still be useful in facilitating SPI read sequences. In this case, the data-ready signal pulses high for approximately 26  $\mu\text{s}$  before returning low and then repeats this pattern at two times the internal sample rate. This signal can feed a counter circuit (or firmware), which drives a processor interrupt routine at a reduced sample rate.

#### Reading TEMP Output Data

Reading TEMP data requires a sequence that is very similar to that of Figure 13, except that the initial SDI sequence must be changed from 0x48 to 0x4A. If the TEMP data is not used, Step 7 to Step 10 of the configuration sequence are not required.

# ADIS16130

## CONFIGURATION OPTIONS

### Synchronization Input

The  $\overline{\text{SYNC}}$  pin can be used to synchronize the ADIS16130 with other devices in the system. When the  $\overline{\text{SYNC}}$  bit in the I/O port register (IOP) is set and the  $\overline{\text{SYNC}}$  pin is low, the ADIS16130 does not process any conversions. Instead, it waits until the  $\overline{\text{SYNC}}$  pin goes high, and then starts the operation. This allows the conversion to start from a known point in time (for example, the rising edge of the  $\overline{\text{SYNC}}$  pin).

### Self-Test Function

The self-test function enables system-level diagnostic checks for the entire ADIS16130 sensor/signal conditioning circuit. To activate the self-test function, there must be a logic high signal on all ST pins (see Table 5). When activated, the self-test function results in a rate measurement shift. By comparing the observed shift with the limits specified in this data sheet, users can determine the pass/fail criteria for system-level diagnostic routines.

For normal gyroscope operation, place a logic low input on all ST pins. For systems that do not require this feature, tie all ST pins to GND.

### Analog Bandwidth

The typical  $-3$  dB cutoff frequency for the ADIS16130 is 300 Hz, which is the combined response of two single-pole filters, as shown in Figure 14. Pin ROA1 and Pin ROA2 provide the opportunity for further bandwidth reduction in the first filter stage, as shown in the following relationship:

$$f_{-3dB} = \frac{1}{2 \times \pi \times R \times (C + C_{ext})}$$

where:

$R = 25 \text{ k}\Omega$ .

$C = 6800 \text{ pF}$ .

$C_{ext}$  is as defined in Figure 15 and Table 7.

The relationship between the  $-3$  dB cutoff frequency and the external capacitance of the ADIS16130 is shown in Table 7 and Figure 15.

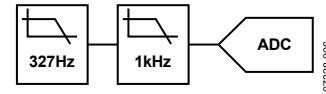

Figure 14. Frequency Response Block Diagram

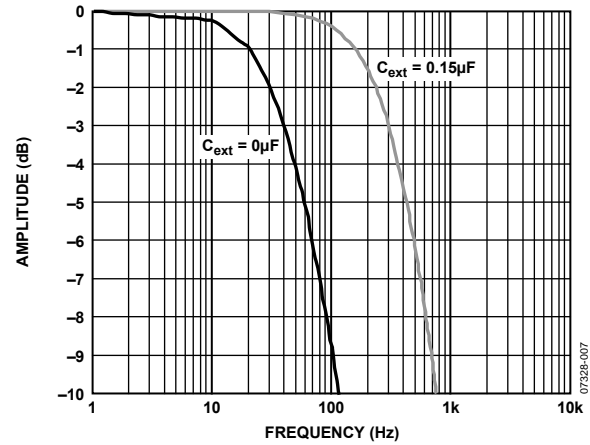

Figure 15. Frequency Response:  $C_{ext} = 0 \mu\text{F}$  vs.  $C_{ext} = 0.15 \mu\text{F}$

Table 7. Nominal Bandwidth for Standard Capacitor Values

$C_{ext}$ (pF)	BW (Hz)	$C_{ext}$ (pF)	BW (Hz)	$C_{ext}$ (pF)	BW (Hz)
1000	276.8	10,000	198.9	100,000	52.2
1200	274.4	12,000	187.2	120,000	44.8
1500	270.9	15,000	172.1	150,000	37.0
1800	267.5	18,000	159.2	180,000	31.5
2200	263.1	22,000	144.7	220,000	26.3
2700	257.7	27,000	129.9	270,000	21.8
3300	251.6	33,000	115.7	330,000	18.1
3900	245.8	39,000	104.4	390,000	15.5
4300	242.1	43,000	97.9	430,000	14.1
4700	238.4	47,000	92.3	470,000	12.9
5100	234.9	51,000	87.2	510,000	12.0
5600	230.7	56,000	81.6	560,000	10.9
6200	225.8	62,000	75.8	620,000	9.9
7500	215.8	75,000	65.6	750,000	8.2
8200	210.8	82,000	61.2	820,000	7.6
9100	204.7	91,000	56.3	910,000	6.8

## CONTROL REGISTERS

**Table 8. Register Descriptions**

Name	Address	Type	Purpose
COM	0x00	W	Facilitate communications in the SPI port (see Table 9)
IOP	0x01	R/W	Data-ready and synchronization controls (see Table 10)
	0x02 to 0x07		Reserved
RATEDATA	0x08	R	Gyroscope output, rate of rotation (see Figure 13)
TEMPDATA	0x0A	R	Temperature output (see Figure 13)
	0x10 to 0x22		Reserved
RATECS	0x28	R/W	Gyroscope channel setup (see Table 11)
TEMPCS	0x2A	R/W	Temperature channel setup (see Table 12)
RATECONV	0x30	R/W	Gyroscope conversion time control (see Table 13)
TEMPCONV	0x32	R/W	Temperature conversion time control (see Table 13)
	0x33 to 0x37		Reserved
MODE	0x38	R/W	Resolution mode control (see Table 14)

### CONTROL REGISTER DETAILS

**Table 9. COM Register Bit Assignments**

Bit	Description
[7]	0
[6]	1 = read; 0 = write
[5:0]	Register address

**Table 10. IOP Register Bit Assignments**

Bit	Description
[7:4]	0011
[3]	1 = data-ready signal low when unread data on all channels; 0 = data-ready signal low when unread data on one channel
[2:1]	00
[0]	0 = synchronization disabled; 1 = synchronization enabled

**Table 11. RATECS Register Bit Assignments**

Bit	Description
[7:4]	0000
[3]	1 = channel enable; 0 = channel disable
[2:0]	010

**Table 12. TEMPCS Register Bit Assignments**

Bit	Description
[7:4]	0000
[3]	1 = channel enable; 0 = channel disable
[2:0]	010

**Table 13. RATECONV/TEMPCONV Bit Assignments**

Bit	Description
[7:0]	00000101

**Table 14. MODE Register Bit Assignments**

Bit	Description
[7:2]	001000
[1]	1 = 24-bit resolution; 0 = 16-bit resolution
[0]	0

## APPLICATIONS INFORMATION

### ACHIEVING OPTIMAL NOISE PERFORMANCE

Several system-level considerations can have an impact on the noise and accuracy of the ADIS16130. Understanding and managing these factors can influence the behavior of any high performance system.

#### Supply and Common Considerations

The ADIS16130 provides approximately 1.8  $\mu\text{F}$  of decoupling capacitance. This capacitance is distributed throughout the device and should be taken into account when considering potential noise threats on the power supply lines.

#### Bandwidth Setting

If  $C_{OUT}$  is applied to reduce the bandwidth of the ADIS16130 response, it should be placed close to the device. Long cable leads and PCB traces increase the risk of introducing noise into the system.

## SECOND-LEVEL ASSEMBLY

The ADIS16130 package supports two mounting approaches: a bulkhead mount, where the interface is separate from the attachment surface, and a PCB mount, which provides the mechanical and electrical connections on the same surface.

Figure 16 provides a suggested design for the ADIS16130's mechanical attachment. The hole pattern shown in Figure 16 can support either mounting approach and enables the integration of the mating socket layout, which is illustrated in Figure 17.

The mating socket layout uses the Samtec CLM-112-02 family of connectors. The 24 holes that are inside the pad accommodate the pins on the ADIS16130, which can extend beyond the package body. The stress relief provided by these holes is important for maintaining reliability and optimal bias stability performance.

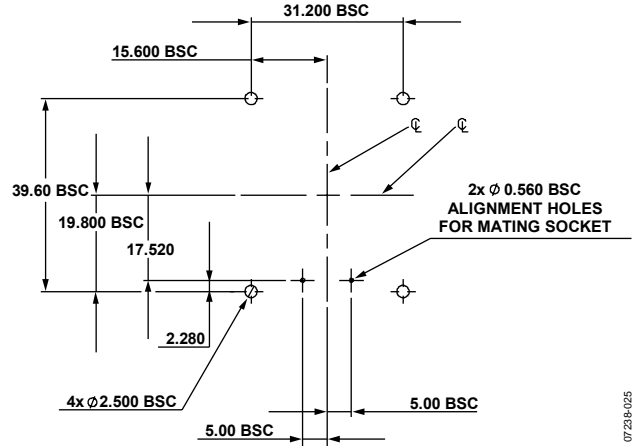

Figure 16. Suggested Hole Pattern for Mounting

0728-025

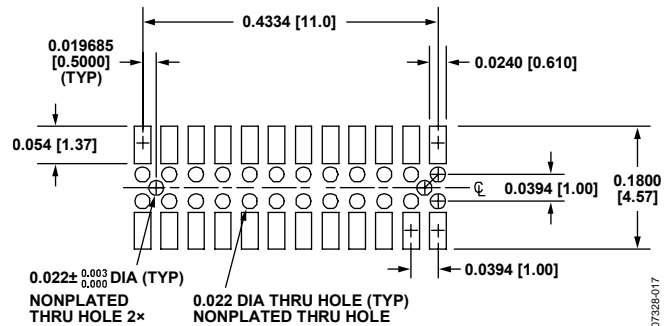

Figure 17. Mating Socket Recommended Pad Layout, with Dimensions Shown in Inches (Millimeters)

07328-017

OUTLINE DIMENSIONS

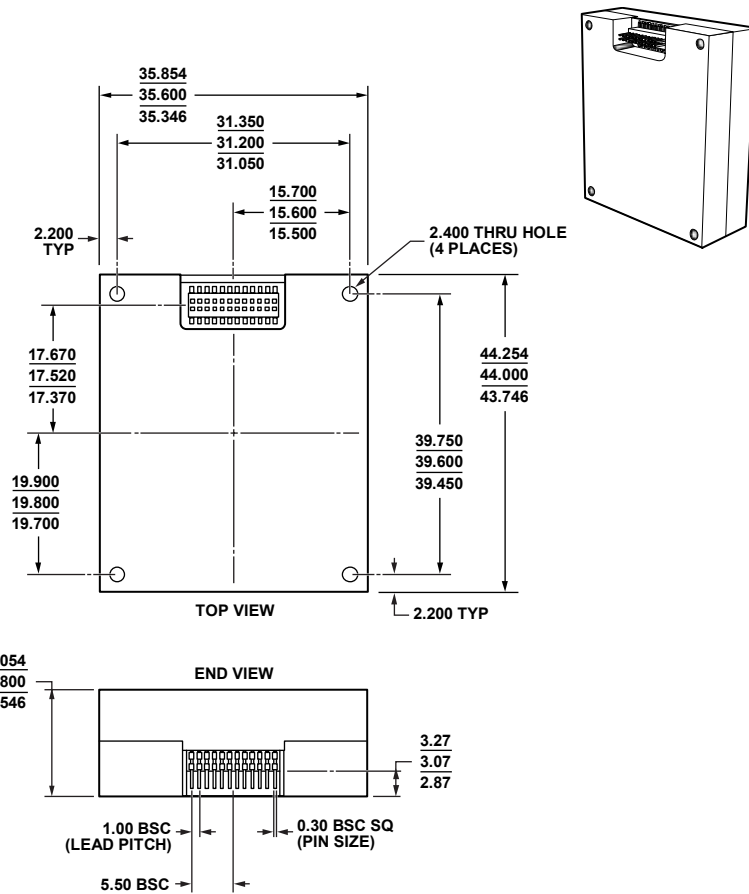

Figure 18. PCB Module with Connector Interface (ML-24-3)  
Dimensions shown in millimeters

010908-A

ORDERING GUIDE

Model	Temperature Range	Package Description	Package Option
ADIS16130AMLZ <sup>1</sup>	-40°C to +105°C	PCB Module with Connector Interface	ML-24-3

<sup>1</sup> Z = RoHS Compliant Part.

**ADIS16130**

**NOTES**

**NOTES**

**ADIS16130**

**NOTES**