

# SGM3157

# 4.5Ω Low Voltage SPDT Analog Switch in 6-pin SC70

## GENERAL DESCRIPTION

The SGM3157 is a single, bidirectional, single-pole/double-throw (SPDT) CMOS analog switches designed to operate from a single +1.8V to +5.5V supply. It features high-bandwidth (300MHz) and low ON-resistance (4.5Ω typ), Targeted applications for audio switching.

SGM3157 features guaranteed on-resistance matching (0.3Ω max) between switches and guaranteed on-resistance flatness over the signal range (2.3Ω TYP). This ensures excellent linearity and low distortion when switching audio signals.

SGM3157 is available in a SC70-6 package.

## APPLICATIONS

Portable Instrumentation  
Battery-Operated Equipment  
Computer Peripherals  
Cell Phones  
PDAs  
MP3s

## FUNCTION TABLE

LOGIC	NO	NC
0	OFF	ON
1	ON	OFF

Switches Shown For Logic "0" Input

## FEATURES

- Voltage Operation : 1.8 V to 5.5 V
- On-Resistance: 4.5Ω (typ) at 5.0V
- Fast Switching Time
  - ton 20 ns
  - toff 15 ns
- High Bandwidth: 300 MHz
- High Off-Isolation: 51dB at 10MHz
- Rail-to-Rail Operation
- TTL/CMOS Compatible
- Break-Before-Make Switching
- Extended Industrial Temperature Range:
  - 40°C to 85°C
- Lead (Pb) Free SC70-6 Package

## PIN CONFIGURATIONS (TOP VIEW)

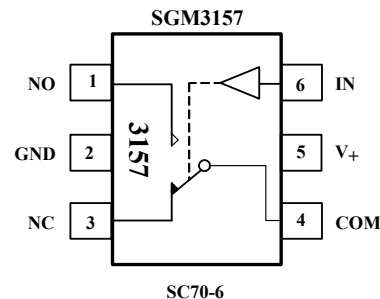

## PIN DESCRIPTION

NAME	PIN	FUNCTION
NO	1	Normally-open terminal
GND	2	ground
NC	3	Normally-closed terminal
COM	4	Common terminal
V+	5	Power supply
IN	6	Digital control pin to connect the COM terminal to the NO or NC terminals

Note: NO, NC and COM terminal may be an input or output.



# ELECTRICAL CHARACTERISTICS

( $V_+ = +2.7V$  to  $+3.6V$ ,  $V_{IH} = +1.4V$ ,  $V_{IL} = +0.5V$ ,  $T_A = -40^\circ C$  to  $+85^\circ C$ , Typical values are at  $V_+ = 3.0V$ ,  $T_A = +25^\circ C$ , unless otherwise noted.)

PARAMETER	SYMBOL	CONDITIONS	TEMP	MIN	TPY	MAX	UNITS
<b>ANALOG SWITCH</b>							
Analog Signal Range	$V_{NO}, V_{NC}, V_{COM}$		-40°C to +85°C	0		$V_+$	V
On-Resistance	$R_{ON}$	$V_+ = 2.7V, V_{NO}$ or $V_{NC} = 1.5V,$ $I_{COM} = -10mA, \text{Test Circuit 1}$	+25°C		7	10	$\Omega$
			-40°C to +85°C			10.5	$\Omega$
On-Resistance Match Between Channels	$\Delta R_{ON}$	$V_+ = 2.7V, V_{NO}$ or $V_{NC} = 1.5V,$ $I_{COM} = -10mA, \text{Test Circuit 1}$	+25°C		0.15	0.3	$\Omega$
			-40°C to +85°C			0.4	$\Omega$
On-Resistance Flatness	$R_{FLAT(ON)}$	$V_+ = 2.7V, V_{NO}$ or $V_{NC} = 1.0V, 1.5V,$ $2.0V, I_{COM} = -10mA, \text{Test Circuit 1}$	+25°C		3	4	$\Omega$
			-40°C to +85°C			4.3	$\Omega$
Source OFF Leakage current	$I_{NC(OFF)}, I_{NO(OFF)}$	$V_+ = 3.6V, V_{NO}$ or $V_{NC} = 0.3V, 3.3V,$ $V_{COM} = 0.3V, 3.3V,$	-40°C to +85°C			1	$\mu A$
Channel ON Leakage current	$I_{NC(ON)}, I_{NO(ON)},$ $I_{COM(ON)}$	$V_+ = 3.6V, V_{COM} = 0.3V, 3.3V,$ $V_{NO}$ or $V_{NC} = 0.3V, 3.3V,$ or floating	-40°C to +85°C			1	$\mu A$
<b>DIGITAL INPUTS</b>							
Input High Voltage	$V_{INH}$		-40°C to +85°C	1			V
Input Low Voltage	$V_{INL}$		-40°C to +85°C			0.5	V
Input Leakage Current	$I_{IN}$	$V_+ = +3.6V, V_{IN} = 0$ or $5.5V$	-40°C to +85°C			1	$\mu A$
<b>DYNAMIC CHARACTERISTICS</b>							
Turn-On Time	$t_{ON}$	$V_{NO}$ or $V_{NC} = 1.5V,$ $R_L = 300\Omega, C_L = 35pF, \text{Test Circuit 2};$ $V_{IH} = 1.5V, V_{IL} = 0V$	+25°C		30		ns
Turn-Off Time	$t_{OFF}$	$V_{NO}$ or $V_{NC} = 1.5V,$ $R_L = 300\Omega, C_L = 35pF, \text{Test Circuit 2};$ $V_{IH} = 1.5V, V_{IL} = 0V$	+25°C		25		ns
Break-Before-Make Time Delay	$t_D$	$V_{NO1}$ or $V_{NC1} = V_{NO2}$ or $V_{NC2} = 3V,$ $R_L = 300\Omega, C_L = 35pF, \text{Test Circuit 3}$	+25°C		8		ns
Skew	$t_{SKEW}$	$R_S = 39\Omega, C_L = 50pF, \text{Test Circuit 4}$	+25°C		2		ns
Off Isolation	$O_{ISO}$	$R_L = 50\Omega, C_L = 5pF,$ Signal = 0dBm, Test Circuit 5	f = 10MHz	+25°C		-51	dB
			f = 1MHz	+25°C		-72	dB
Bandwidth -3 dB	BW	Signal = 0dBm, $R_L = 50\Omega, C_L = 5pF,$ Test Circuit 6	+25°C		300		MHz
Source OFF Capacitance	$C_{NC(OFF)}, C_{NO(OFF)}$	f = 1MHz	+25°C		5.5		pF
Channel ON Capacitance	$C_{NC(ON)}, C_{NO(ON)},$ $C_{COM(ON)}$	f = 1MHz	+25°C		15.5		pF
<b>POWER REQUIREMENTS</b>							
Power Supply Range	$V_+$		-40°C to +85°C	1.8		5.5	V
Power Supply Current	$I_+$	$V_+ = +5.5V, V_{IN} = 0V$ or $V_+$	-40°C to +85°C			5	$\mu A$

Specifications subject to change without notice.

# ELECTRICAL CHARACTERISTICS

( $V_+ = +4.5V$  to  $+5.5V$ ,  $V_{IH} = +2.0V$ ,  $V_{IL} = +0.8V$ ,  $T_A = -40^\circ C$  to  $+85^\circ C$ , Typical values are at  $V_+ = 5.0V$ ,  $T_A = +25^\circ C$ , unless otherwise noted.)

PARAMETER	SYMBOL	CONDITIONS	TEMP	MIN	TPY	MAX	UNITS
<b>ANALOG SWITCH</b>							
Analog Signal Range	$V_{NO}, V_{NC}, V_{COM}$		-40°C to +85°C	0		$V_+$	V
On-Resistance	$R_{ON}$	$V_+ = 4.5V, V_{NO}$ or $V_{NC} = 3.5V,$ $I_{COM} = -10$ mA, Test Circuit 1	+25°C		4.5	8	$\Omega$
			-40°C to +85°C			8.5	$\Omega$
On-Resistance Match Between Channels	$\Delta R_{ON}$	$V_+ = 4.5V, V_{NO}$ or $V_{NC} = 3.5V,$ $I_{COM} = -10$ mA, Test Circuit 1	+25°C		0.15	0.3	$\Omega$
			-40°C to +85°C			0.4	$\Omega$
On-Resistance Flatness	$R_{FLAT(ON)}$	$V_+ = 4.5V, V_{NO}$ or $V_{NC} = 1.0V, 2.0V,$ $3.5V, I_{COM} = -10$ mA, Test Circuit 1	+25°C		2.3	3.3	$\Omega$
			-40°C to +85°C			3.7	$\Omega$
Source OFF Leakage current	$I_{NC(OFF)}, I_{NO(OFF)}$	$V_+ = 5.5V, V_{NO}$ or $V_{NC} = 1.0V, 4.5V,$ $V_{COM} = 1.0V, 4.5V,$	-40°C to +85°C			1	$\mu A$
Channel ON Leakage current	$I_{NC(ON)}, I_{NO(ON)},$ $I_{COM(ON)}$	$V_+ = 5.5V, V_{COM} = 1.0V, 4.5V,$ $V_{NO}$ or $V_{NC} = 1.0V, 4.5V,$ or floating	-40°C to +85°C			1	$\mu A$
<b>DIGITAL INPUTS</b>							
Input High Voltage	$V_{INH}$		-40°C to +85°C	1.5			V
Input Low Voltage	$V_{INL}$		-40°C to +85°C			0.6	V
Input Leakage Current	$I_{IN}$	$V_+ = +5.5V, V_{IN} = 0$ or $5.5V$	-40°C to +85°C			1	$\mu A$
<b>DYNAMIC CHARACTERISTICS</b>							
Turn-On Time	$t_{ON}$	$V_{NO}$ or $V_{NC} = 3.0V,$ $R_L = 300\Omega, C_L = 35pF,$ Test Circuit 2; $V_{IH} = 1.5V, V_{IL} = 0V$	+25°C		20		ns
Turn-Off Time	$t_{OFF}$	$V_{NO}$ or $V_{NC} = 3.0V,$ $R_L = 300\Omega, C_L = 35pF,$ Test Circuit 2; $V_{IH} = 1.5V, V_{IL} = 0V$	+25°C		15		ns
Break-Before-Make Time Delay	$t_d$	$V_{NO1}$ or $V_{NC1} = V_{NO2}$ or $V_{NC2} = 3V,$ $R_L = 300\Omega, C_L = 35pF,$ Test Circuit 3	+25°C		5		ns
Skew	$t_{SKEW}$	$R_S = 39\Omega, C_L = 50pF,$ Test Circuit 4	+25°C		5		ns
Off Isolation	$O_{ISO}$	$R_L = 50\Omega, C_L = 5pF,$ Signal = 0dBm, Test Circuit 5	$f = 10MHz$	+25°C		-51	dB
			$f = 1MHz$	+25°C		-72	dB
Bandwidth -3 dB	BW	Signal = 0dBm, $R_L = 50\Omega, C_L = 5pF,$ Test Circuit 6	+25°C		300		MHz
Source OFF Capacitance	$C_{NC(OFF)}, C_{NO(OFF)}$	$f = 1MHz$	+25°C		5.5		pF
Channel ON Capacitance	$C_{NC(ON)}, C_{NO(ON)},$ $C_{COM(ON)}$	$f = 1MHz$	+25°C		15.5		pF
<b>POWER REQUIREMENTS</b>							
Power Supply Range	$V_+$		-40°C to +85°C	1.8		5.5	V
Power Supply Current	$I_+$	$V_+ = +5.5V, V_{IN} = 0V$ or $V_+$	-40°C to +85°C			5	$\mu A$

Specifications subject to change without notice.

## ORDERING INFORMATION

MODEL	PIN-PACKAGE	SPECIFIED TEMPERATURE RANGE	ORDERING NUMBER	PACKAGE MARKING	PACKAGE OPTION
SGM3157	SC70-6	- 40°C to +85°C	SGM3157YC6/TR	3157	Tape and Reel, 3000

## ABSOLUTE MAXIMUM RATINGS

V <sub>+</sub> , IN to GND.....	- 0.3V to +6V	Junction Temperature.....	+150°C
Analog, Digital voltage range(1).....	- 0.3V to (V <sub>+</sub> + 0.3V)	Storage Temperature.....	- 65°C to +150°C
Continuous Current NO, NC, or COM.....	± 200mA	Lead Temperature (soldering, 10s).....	+260°C
Peak Current NO, NC, or COM.....	± 300mA	ESD (HBM).....	2000V
Operating Temperature Range.....	- 40°C to +85°C		

Stresses beyond those listed under “Absolute Maximum Ratings” may cause permanent damage to the device. These are stress ratings only, and functional operation of the device at these or any other conditions beyond those indicated in the operational sections of the specifications is not implied. Exposure to absolute maximum rating conditions for extended periods may affect device reliability.

(1) Signals on NC, NO, or COM or IN exceeding V<sub>+</sub> will be clamped by internal diodes. Limit forward diode current to maximum current ratings.

# TYPICAL PERFORMANCE CHARACTERISTICS

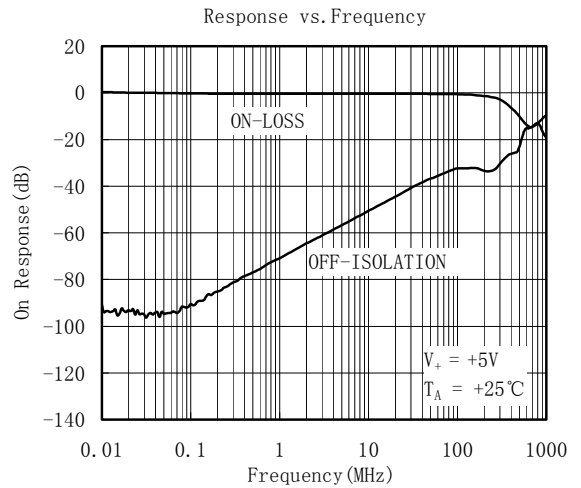
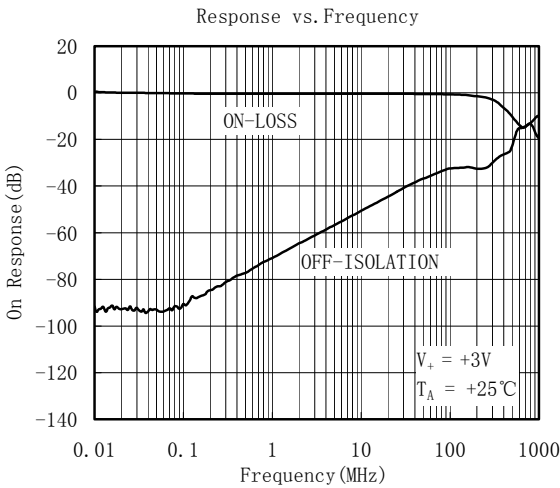
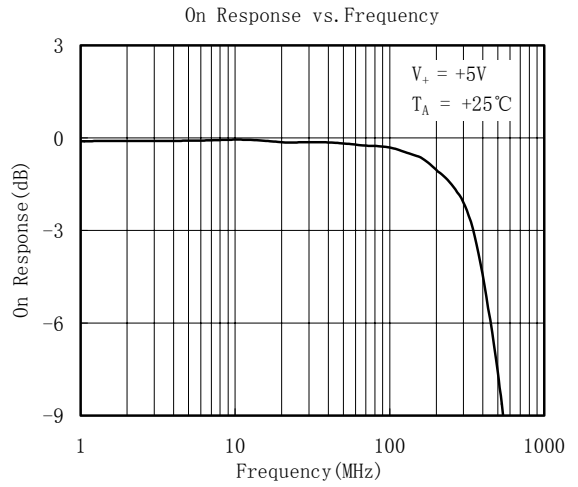
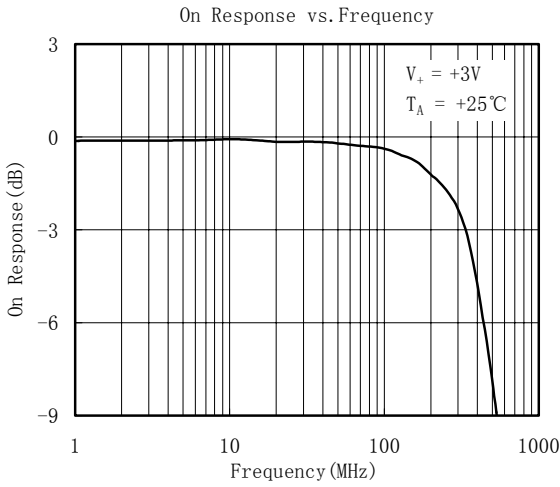

# TEST CIRCUITS

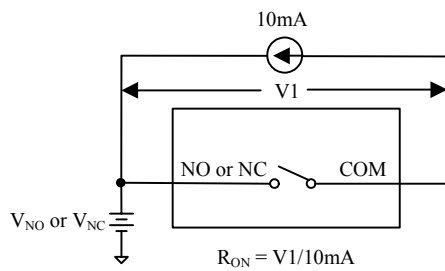

Test Circuit 1. On Resistance

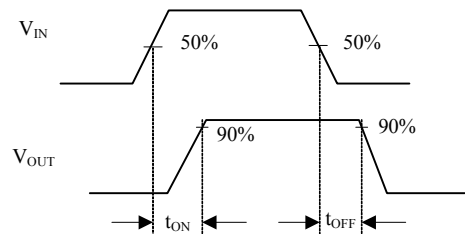
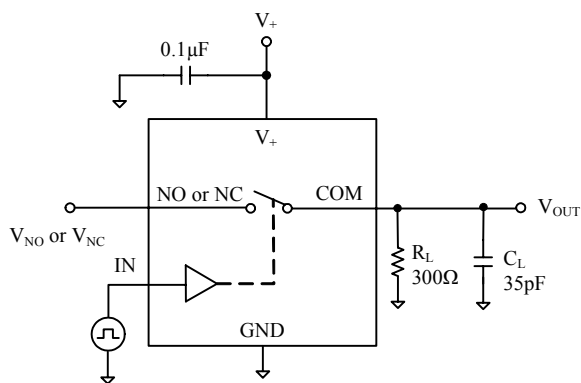

Test Circuit 2. Switching Times

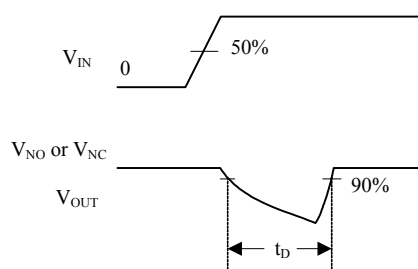
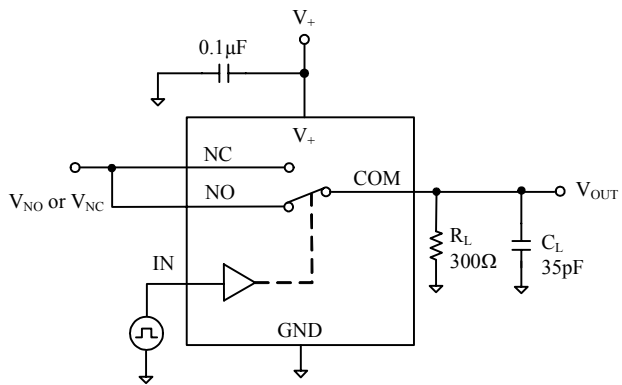

Test Circuit 3. Break-Before-Make Time Delay,  $t_D$

## TEST CIRCUITS (Cont.)

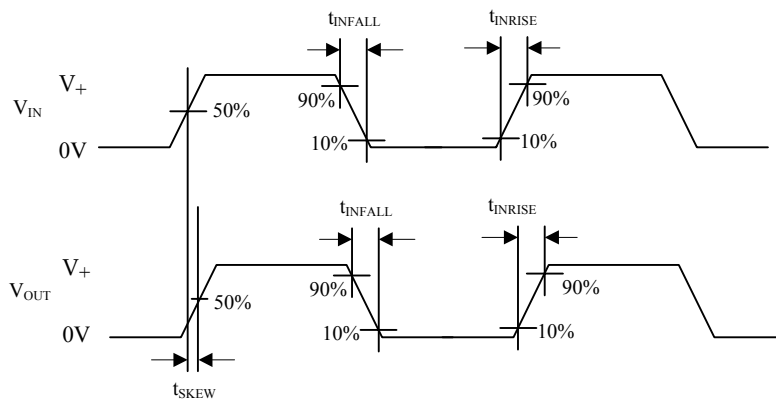
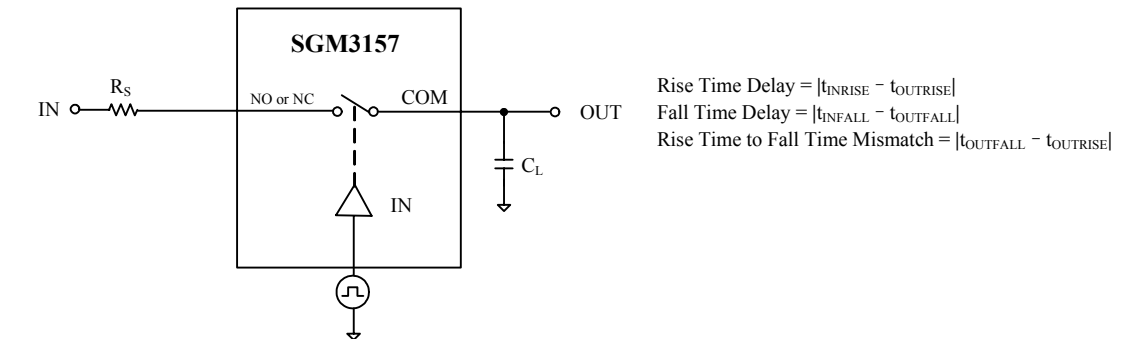

Test Circuit 4. Output Signal Skew

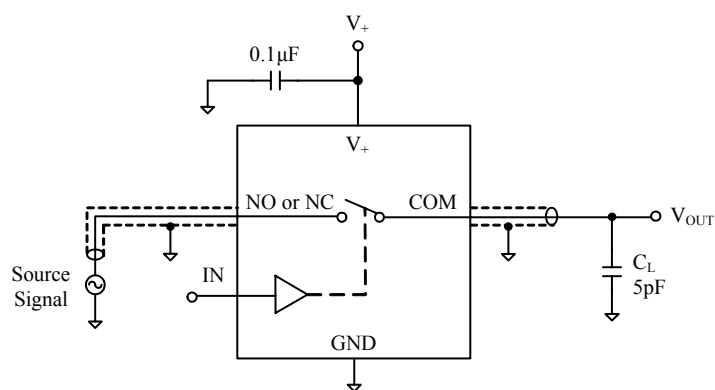

Test Circuit 5. Off Isolation

## TEST CIRCUITS (Cont.)

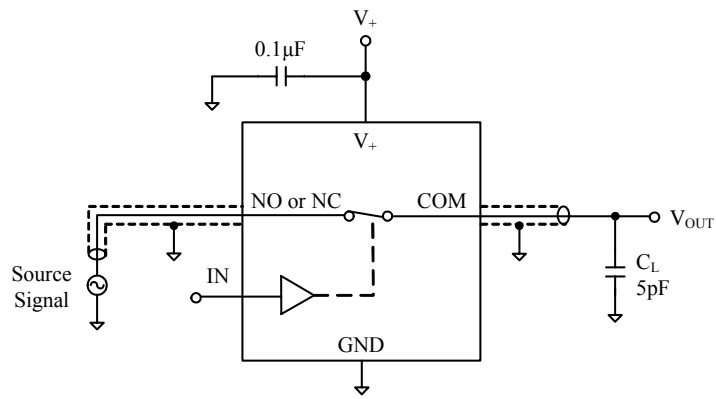

Test Circuit 6. Bandwidth



# PACKAGE OUTLINE DIMENSIONS

## SC70-6

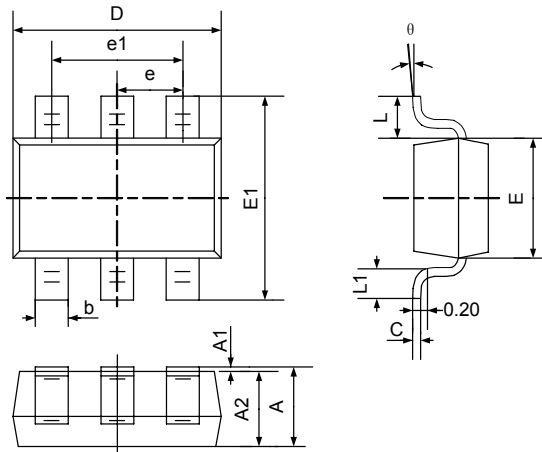

Symbol	Dimensions In Millimeters		Dimensions In Inches	
	Min	Max	Min	Max
A	0.900	1.100	0.035	0.043
A1	0.000	0.100	0.000	0.004
A2	0.900	1.000	0.035	0.039
b	0.150	0.350	0.006	0.014
c	0.080	0.150	0.003	0.006
D	2.000	2.200	0.079	0.087
E	1.150	1.350	0.045	0.053
E1	2.150	2.450	0.085	0.096
e	0.650TYP		0.026TYP	
e1	1.200	1.400	0.047	0.055
L	0.525REF		0.021REF	
L1	0.260	0.460	0.010	0.018
θ	0°	8°	0°	8°

# REVISION HISTORY

Location	Page
<b>08/07— Data Sheet REV.A</b>	
<b>10/07— Data Sheet changed from REV.A to REV.B</b>	
Changes to TYPICAL PERFORMANCE CHARACTERISTICS .....	5

## Shengbang Microelectronics Co, Ltd

Unit 3, ChuangYe Plaza  
No.5, TaiHu Northern Street, YingBin Road Centralized Industrial Park  
Harbin Development Zone  
Harbin, HeiLongJiang 150078  
P.R. China  
Tel.: 86-451-84348461  
Fax: 86-451-84308461  
[www.sg-micro.com](http://www.sg-micro.com)