

SCHOTTKY BARRIER RECTIFIER

VOLTAGE RANGE: 45 V
CURRENT: 25 A

FEATURES

- ◇ High surge capacity.
- ◇ For use in low voltage, high frequency inverters, free wheeling, and polarity protection applications.
- ◇ Metal silicon junction, majority carrier conduction.
- ◇ High current capacity, low forward voltage drop.
- ◇ Guard ring for over voltage protection.

MECHANICAL DATA

- ◇ Case: JEDEC D²PAK, molded plastic body
- ◇ Terminals: Leads, solderable per MIL-STD-750, Method 2026
- ◇ Polarity: As marked
- ◇ Position: Any
- ◇ Weight: 0.087 ounces, 2.2 grams

D²PAK

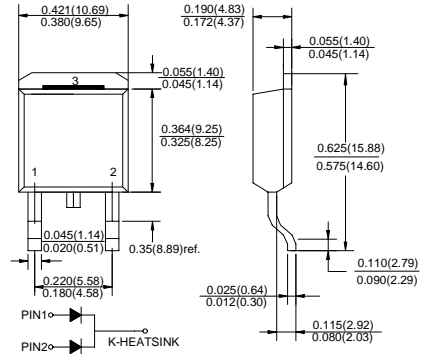

inch(mm)

MAXIMUM RATINGS AND ELECTRICAL CHARACTERISTICS

Ratings at 25°C ambient temperature unless otherwise specified.

Single phase, half wave, 60Hz, resistive or inductive load. For capacitive load, derate current by 20%.

		MBRB2545CT	UNITS
Maximum recurrent peak reverse voltage	V_{RRM}	45	V
Maximum RMS Voltage	V_{RMS}	32	V
Maximum DC blocking voltage	V_{DC}	45	V
Maximum average forward total device rectified current @ $T_c = 130^\circ\text{C}$	$I_{F(AV)}$	25	A
Peak forward surge current 8.3ms single half sine-wave superimposed on rated load	I_{FSM}	150	A
Maximum forward voltage (Note 1) ($I_F=30\text{A}, T_c=25^\circ\text{C}$)	V_F	0.82	V
($I_F=30\text{A}, T_c=125^\circ\text{C}$)		0.73	
Maximum reverse current @ $T_c=25^\circ\text{C}$	I_R	0.2	mA
at rated DC blocking voltage @ $T_c=125^\circ\text{C}$		40	
Maximum thermal resistance (Note2)	$R_{\theta JC}$	1.5	$^\circ\text{C/W}$
Operating junction temperature range	T_J	- 55 ---- + 150	$^\circ\text{C}$
Storage temperature range	T_{STG}	- 55 ---- + 150	$^\circ\text{C}$

NOTE: 1. Pulse test: 300µs pulse width, 1% duty cycle.

2. Thermal resistance from junction to case.

www.galaxyen.com

FIG.1 – PEAK FORWARD SURGE CURRENT

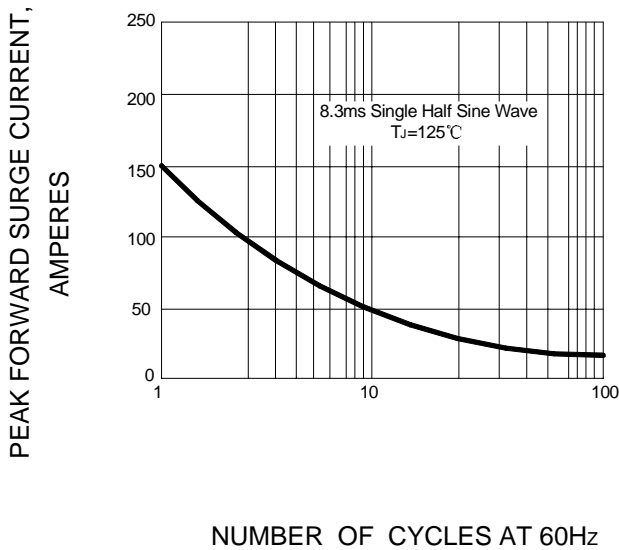

FIG.2 – FORWARD DERATING CURVE

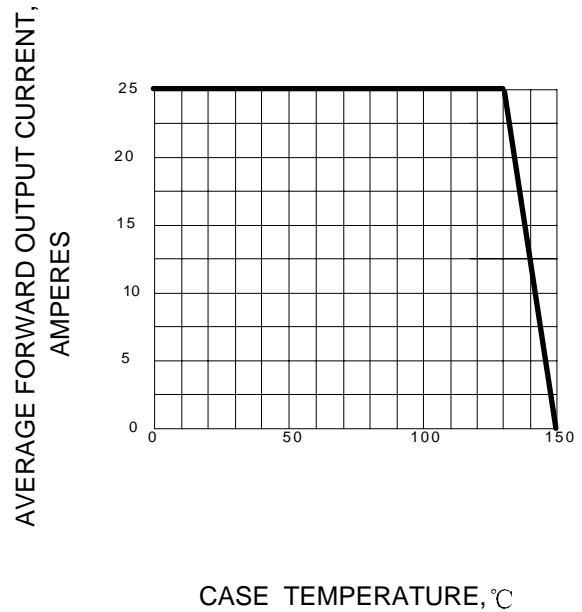

FIG.3 – TYPICAL FORWARD CHARACTERISTIC

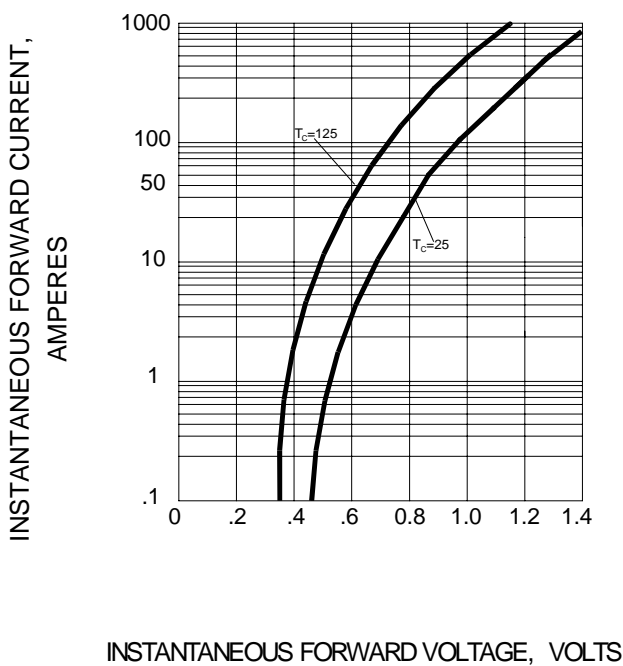

FIG.4 – TYPICAL REVERSE CHARACTERISTICS

