

HTS2030SMD Temperature and Relative Humidity Sensor

DESCRIPTION

Based on a unique capacitive cell for humidity measurement and a Negative Temperature Coefficient (NTC) thermistor for temperature measurement, this dual purpose relative humidity / temperature miniaturized sensor is designed for high volume, cost sensitive applications with tight space constraints. It is useful in all applications where dew point, absolute humidity measurements or humidity compensation are required.

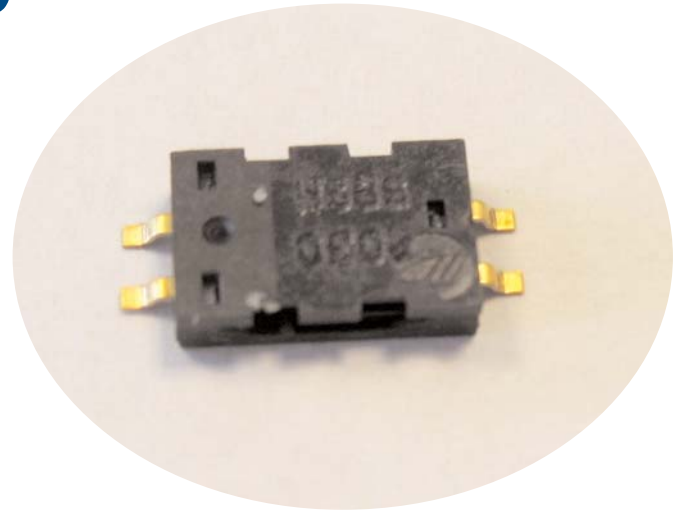

FEATURES

- ◆ Miniature Surface Mount SMD Package
- ◆ Lead Free Components
- ◆ Full Interchangeability with no calibration required in standard conditions
- ◆ Instantaneous desaturation after long periods in saturation phase
- ◆ Compatible with automatized assembly processes, including Pb free wave soldering and reflow processes ⁽¹⁾
- ◆ High Reliability and Long Term Stability
- ◆ Patented Solid Polymer Structure
- ◆ Suitable for linear voltage or frequency output circuitry
- ◆ Fast response time and very low temperature coefficient
- ◆ Part may be washed with distilled water
- ◆ Individual marking for compliance to stringent traceability requirements

(1) Soldering temperature profiles available upon request/contact us at application@humirel.com

maximum ratings

Ratings	Symbol	Value	Unit
Operating Temperature	Ta	-60 to 140	°C
Storage Temperature	Tstg	-60 to 140	°C
Supply Voltage (Peak)	Vs	10	Vac
Humidity Operating Range	RH	0 to 100	% RH

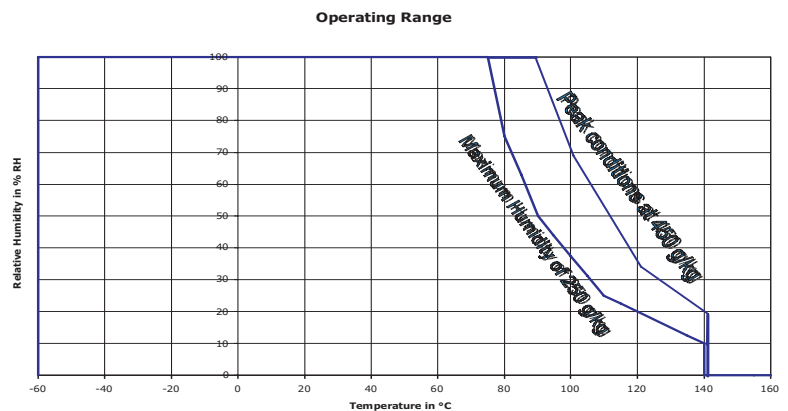

HTS2030SMD Temperature and Relative Humidity Sensor

Characteristics (Ta = 25°C, measurement frequency @ 10kHz unless otherwise stated)

Characteristics	Symbol	Min	Typ	Max	Unit
Humidity metrology range	RH	1		99	% RH
Voltage supply	Vs			10	V
Nominal capacitance @ 55% RH	C	177	180	183	pF
Temperature coefficient	Tcc			0.01	pF/°C
Averaged Sensitivity from 33% to 75% RH	$\Delta C / \% RH$		0.31		pf/% RH
Leakage current (Vcc=5 Volts)	I			1	nA
Recovery time after 150 hours of condensation	tr		10		s
Humidity Hysteresis				+/-1	% RH
Long term stability	t		+/-0.5		% RH/yr
Time constant (33 to 80% RH, still air, @ 63%)	$\tau\alpha$		3	5	s
Deviation to typical response curve (10% to 90% RH)			+/-2		% RH

Typical Response in Humidity

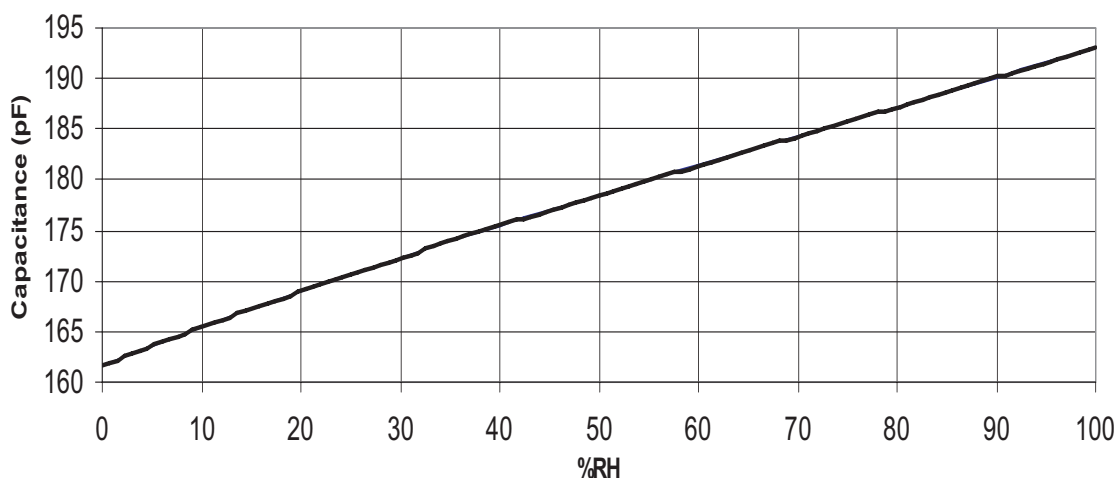

Polynomial response of HTS2030SMD:

$$C \text{ (pF)} = C@55\% * (3.903 \cdot 10^{-8} * RH^3 - 8.294 \cdot 10^{-6} * RH^2 + 2.188 \cdot 10^{-3} * RH + 0.898)$$

Reversed Polynomial response of HTS2030SMD:

$$RH \text{ (%) } = -3.4656 \cdot 10^{+3} * X^3 + 1.0732 \cdot 10^{-4} * X^2 - 1.0457 \cdot 10^{+4} * X + 3.2459 \cdot 10^{+3}$$

With X=C(read) / C@55%RH

Typical response look-up table (Polynomial Reference curve) 10kHz/1V

RH (%)	0	5	10	15	20	25	30	35	40	45	50
Cp (pF)	161.6	163.6	165.4	167.2	169.0	170.7	172.3	173.9	175.5	177.0	178.5
RH (%)	55	60	65	70	75	80	85	90	95	100	
Cp (pF)	180	181.4	182.9	184.3	185.7	187.2	188.6	190.1	191.6	193.1	

HTS2030SMD Temperature and Relative Humidity Sensor

Characteristics Temperature sensor (Ta = 25°C)

Characteristics	Symbol	Min	Typ	Max	Unit
Nominal resistance @ 25°C			10		kΩ
Beta value : B25/100	B	3600	3730	3800	
Temperature measuring range	Ta	- 60		140	°C
Nominal Resistance Tolerance at 25°C	Rn		2	3	%
B value tolerance	B		3		%
Response Time	τ		10		s

Typical temperature output

Depending on the needed temperature measurement range and associated accuracy, we suggest two methods to access to the NTC resistance values.

$$\textcircled{1} \quad R_T = R_{T_0} \cdot e^{B \left(\frac{1}{T} - \frac{1}{T_0} \right)}$$

R_T NTC resistance in Ωat temperature T in K

R_{T_0} NTC resistance in Ωat rated temperature in K

T, T_0 Temperature in K

B B value, material-specific constant of the NTC thermistor

e Base of natural logarithm ($e = 2.71828$)

The actual characteristic of an NTC thermistor can, however, only be roughly described by the exponential relation, as the material parameter B in reality also depends on temperature. So this approach is only suitable for describing a restricted range around the rated temperature or resistance with sufficient accuracy.

$\textcircled{2}$ For practical applications a more precise description of the real R/T curve may be required. Either more complicated approaches (e.g. the Steinhart-Hart equation) are used or the resistance/temperature relation as given in tabulated form. The below table has been experimentally determined with utmost accuracy for temperature increments of 1 degree.

HTS2030SMD Temperature and Relative Humidity Sensor

Temperature °C	Resistance (ohm)	Max. Deviation	Temperature °C	Resistance (ohm)	Max. Deviation	Temperature °C	Resistance (ohm)	Max. Deviation	Temperature °C	Resistance (ohm)	Max. Deviation
-40	262960	35403	-6	40247	2960	28	8853	299	62	2542	182
-39	247217	32777	-5	38279	2756	29	8506	297	63	2458	178
-38	232539	30358	-4	36455	2568	30	8178	296	64	2378	175
-37	218845	28130	-3	34731	2393	31	7866	294	65	2304	171
-36	206064	26075	-2	33100	2230	32	7568	292	66	2229	168
-35	194110	24178	-1	31557	2078	33	7283	290	67	2158	165
-34	182852	22416	0	30029	1932	34	7011	287	68	2089	161
-33	172332	20791	1	28627	1799	35	6734	284	69	2022	158
-32	162498	19290	2	27299	1675	36	6484	281	70	1960	155
-31	153299	17905	3	26042	1560	37	6244	278	71	1898	152
-30	144790	16636	4	24852	1452	38	6015	275	72	1839	149
-29	136664	15444	5	23773	1355	39	5796	271	73	1782	146
-28	129054	14343	6	22708	1261	40	5575	267	74	1727	143
-27	121925	13325	7	21698	1174	41	5373	264	75	1673	140
-26	115243	12383	8	20739	1093	42	5180	260	77	1573	135
-25	109030	11516	9	19829	1017	43	4995	257	79	1480	130
-24	103115	10705	10	18959	946	44	4817	253	81	1390	124
-23	97565	9953	11	18128	879	45	4636	248	83	1310	119
-22	92354	9257	12	17338	817	46	4473	245	85	1235	115
-21	87460	8612	13	16588	759	47	4316	241	86	1199	112
-20	82923	8020	14	15876	705	48	4166	237	87	1163	110
-19	78581	7463	15	15207	654	49	4021	233	88	1130	108
-18	74497	6947	16	14569	607	50	3874	229	89	1097	106
-17	70655	6468	17	13962	563	51	3737	225	90	1067	104
-16	67039	6023	18	13384	522	52	3606	221	91	1038	102
-15	63591	5606	19	12834	484	53	3481	217	92	1009	100
-14	60381	5222	20	12280	447	54	3360	213	93	982	98
-13	57356	4865	21	11777	413	55	3237	208	94	955	96
-12	54503	4533	22	11297	382	56	3126	204	95	927	94
-11	51813	4225	23	10840	353	57	3019	200	96	901	92
-10	49204	3932	24	10404	325	58	2917	197	97	877	90
-9	46767	3662	25	10000	300	59	2819	193	98	853	89
-8	44467	3411	26	9600	300	60	2720	189	99	830	87
-7	42296	3177	27	9218	300	61	2629	185			

Suggested Frequency Output Circuits

Note: R22=499kΩ /
R4=49.9kΩ / R1=1 kΩ /
RV1=50 kΩ potentiometer /
C1=10nF / C2=2.2nF / C3=100nF

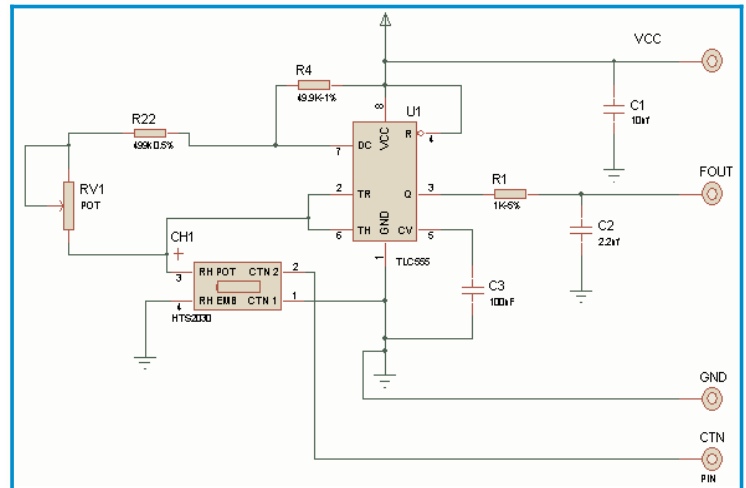

HTS2030SMD Temperature and Relative Humidity Sensor

Typical response look-up table (Humidity Output)

RH (%)	0	5	10	15	20	25	30	35	40	45	50
Fout (Hz)			7155	7080	7010	6945	6880	6820	6760	6705	6650
RH (%)	55	60	65	70	75	80	85	90	95	100	
Fout (Hz)	6600	6550	6500	6450	6400	6355	6305	6260	6210		

Qualification Process

HTS2030SMD sensors have been qualified through a complete qualification process taking in account many of the requirements of the JEDEC standard including:

- Solder heat and solderability including lead free process.
- Pb free wave soldering and reflow soldering process(260°C) + DI water clean at 45°C
- Mechanical shock JESD-22-B104-A
- Vibration - Variable frequency(20 to 2000Hz) JESD-22-B103-A
- Marking permanency
- ESD - Electrostatic Discharge –Air Gun +15kV(IEC 1000)
- Salt Atmosphere JESD22-A107-A
- Temperature Cycling - 40°C / +125°C
- High Temperature / Humidity Operating Life - 93%RH / 60°C for 1000 hours
- Low Humidity storage life - RH < 10%/23°C - 1000 hours
- Resistance to immersion in water at ambient temperature and 80°C
- High temperature storage 140°C for 168 hours.
- Resistance to many chemicals linked to home appliances/automotive or consumer applications.

ENVIRONMENTAL AND RECYCLING

HTS2030SMD sensors are lead free components and are compatible with Pb Free soldering processes. HTS2030SMD sensors are free from Cr (6+), Cd and Hg.

Package Outline HTS2030SMD

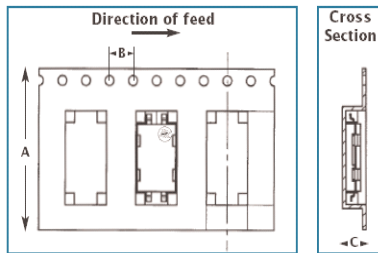
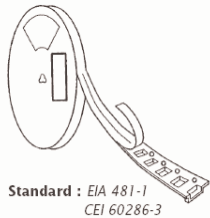
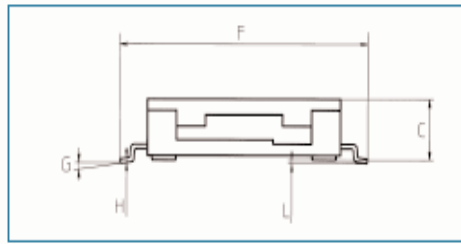
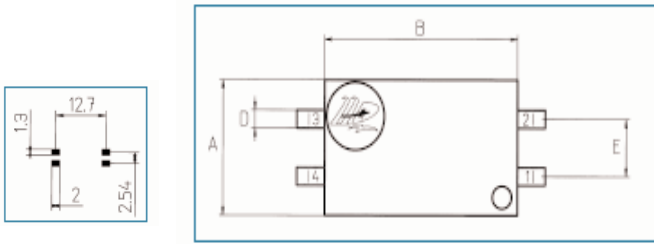

Dim	A	B	C	D	E	F	G	H	L
Min	6	10	2.7	0.8	2.54	12.8	0-7°	0.2	0.1
			A	B	C				
			Carrier	Carrier	Carrier				
Reel		Reel	Tape	Tape	Tape				
Diameter		Width		Pitch	Depth				
360 mm		30.4 mm	24 mm	4 mm	4 mm				

Dimensions in millimeters

Ordering Information: HTS2030SMD

- HPP804B130: TUBE M.P.Q. OF 78 PIECES.
 - HPP804B131: TAPE AND REEL M.P.Q. OF 1500 PIECES.
- TEMPERATURE AND RELATIVE HUMIDITY SENSORS.