



CONSTANT CURRENT CW LASER DRIVER

Description

This laser driver is for driving diode lasers with high stability and high power efficiency. It provides these functions: laser constant current control, laser current monitoring, control loop stability indications, and shut down. It provides a high stability and low noise 2.5V reference voltage which can be used for setting the output current, or for ADCs & DACs.

Main features: high efficiency, low noise, high reliability, zero EMI and small package.

Part number:	CWD-01-V2
Laser current control signal level:	0 to 2.5V
Control accuracy:	±0.2%
Laser current indication signal level:	0 to 2.5V
Indication accuracy:	±0.2%
Maximum output current:	2A
Current output noise:	0.05%
Laser driver efficiency:	≥90%
Power input DC voltage:	3.0V to 5.5V
Output reference voltage:	2.5V
Operating temperature:	-20°C to +85°C

Pin Descriptions

- Pin 1 SDNG**, shut down control, digital input. Negative logic, at the internal chip control input: >1.4V = enable, <0.95V = shut down, nominal threshold voltage = 1.2V. The input current is between 3μA and 8μA. There is a resistor, a Schottky diode, and a capacitor circuit in front of the internal input pin. See Figure 2. This circuit allows a slow start up and a quick shut down.
- Pin 2 LDGD**, laser diode good, digital output. When this pin is high, >1V, the control loop is working properly. When this pin is low, <1V, the laser diode is bad, or there is a short or open circuit at the laser diode. This pin comes from an open drain output and is pulled up by a 100KΩ resistor.
- Pin 3 GND**, signal ground. Connect ADC and DAC grounds to here.
- Pin 4 2.5V**, reference voltage, analog output. It can source 3mA max, with 5μVp-p noise @ 0.1 to 10 Hz and 25ppm/°C stability max.
- Pin 5 LCS**, laser current set-point voltage, analog input. There is an input resistor of 100K tied to GND. Setting it from 0V to 2.5V will set the laser current from 0A to 2A linearly.
- Pin 6 LCO**, laser current output indication, analog output. 0V to 2.5V indicates the laser current of from 0A to 2A linearly.
- Pin 7 GND**, the same as PIN 3.
- Pin 8 LCGD**, laser current good, control loop indication, analog output. When this pin is stabilized and the value is between 0.2V and 1.8V, the output voltage to the laser, Pin 9 LDA, will be 4.8V to 0V



linearly, the laser current is stabilized, and the control loop is stable. This pin has a similar function as Pin 2 LDGD, except that this pin is of an analog output and Pin 2 is of a digital output.

Pin 9 LDA, laser diode anode, analog output. Connect it to the anode of the laser diode.

Pin 10 PGND, power ground. Connect this pin directly to the cathode of the laser diode.

Pin 11 PGND, power ground. Connect this pin directly to power supply return pass.

Pin 12 VPS, power supply voltage, power input. The driver will work from VPS = 3.0V to 5.5V.

Figure 1 illustrates two typical connection schematics.

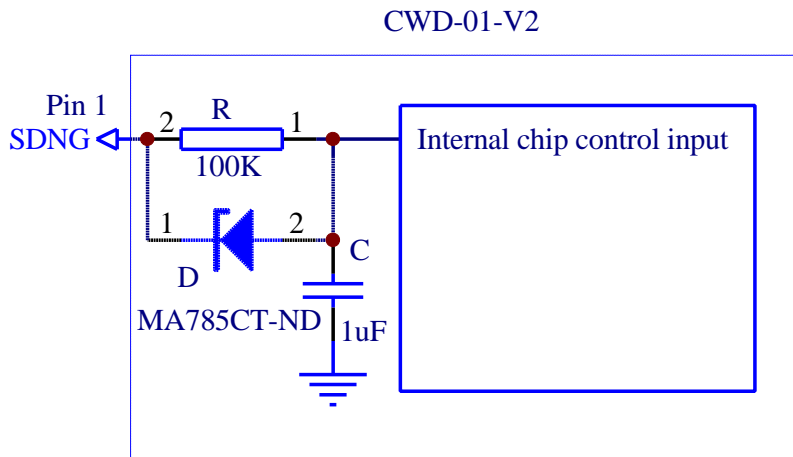

Figure 1

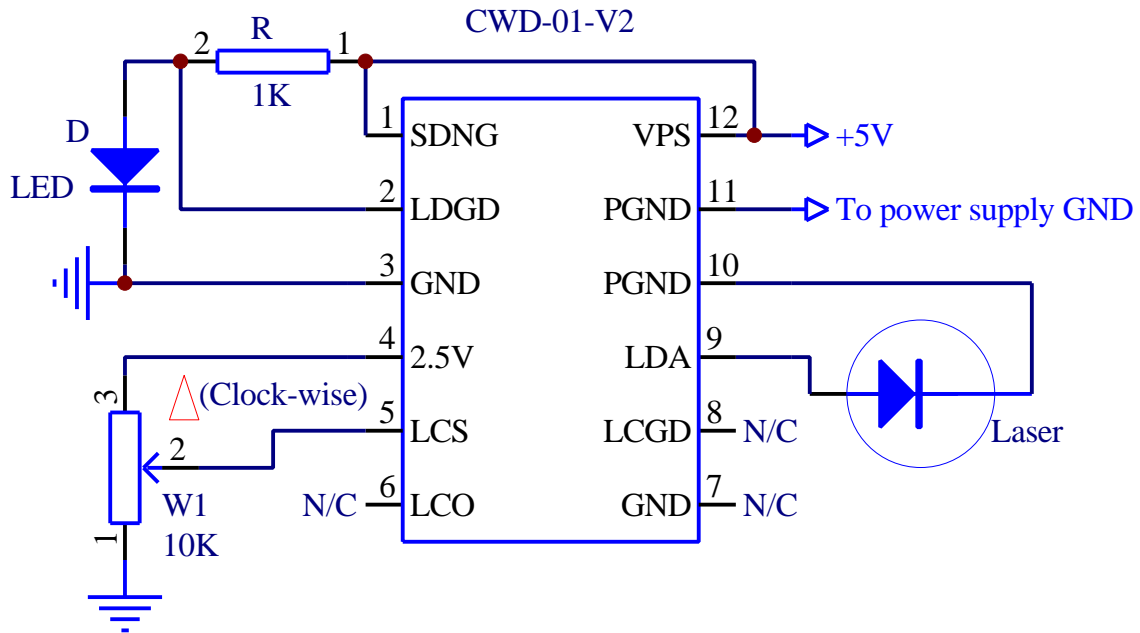

Figure 2A Self-contained

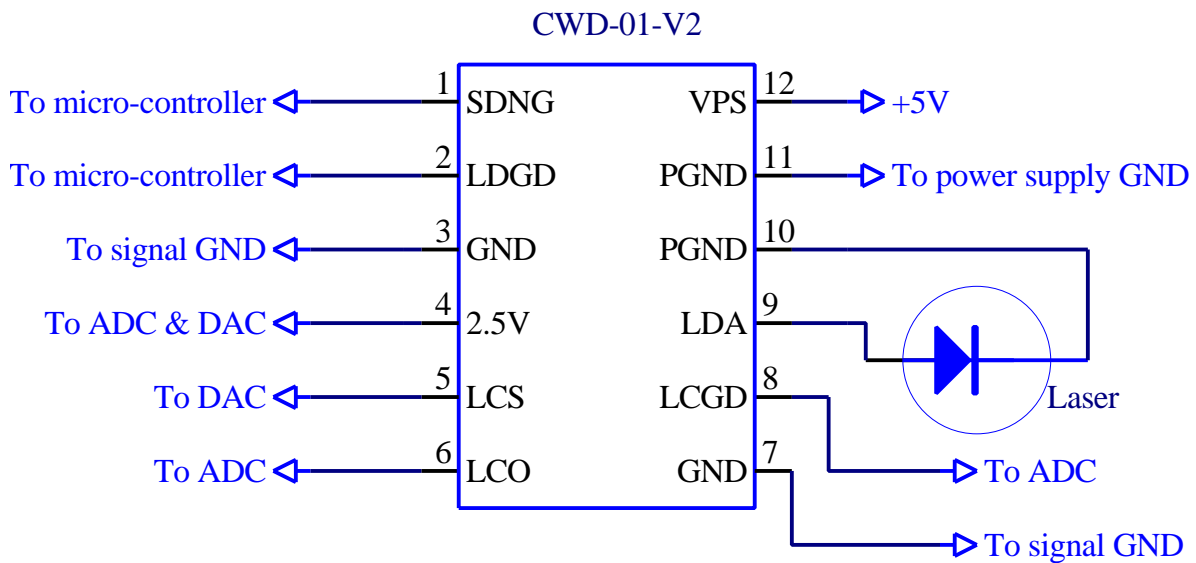

Figure 2B Micro-processor Based



Pin Configurations and Mechanical Dimensions

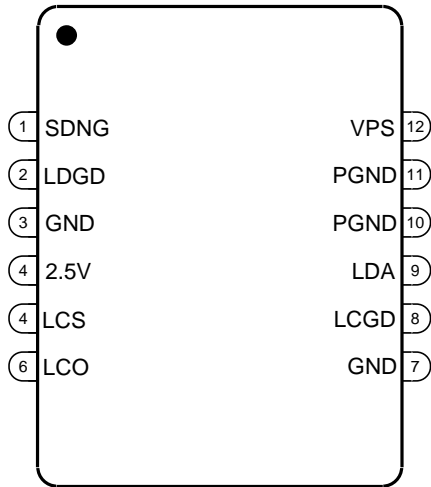

Figure 3 Top View of CWD-01-V2-S

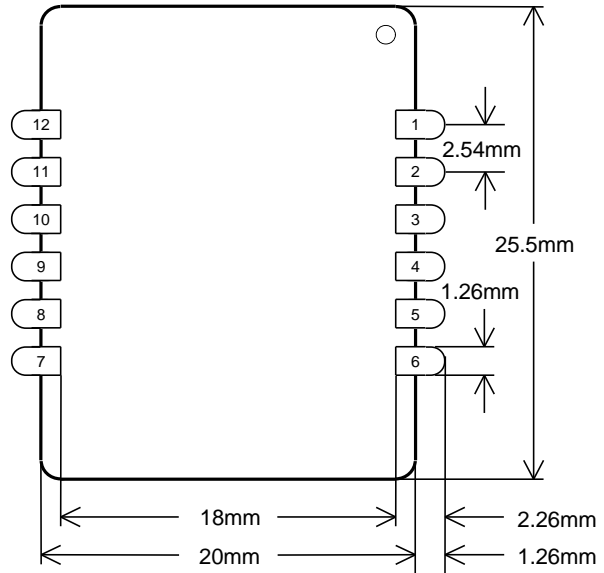

Figure 4 Bottom View of CWD-01-V2-S

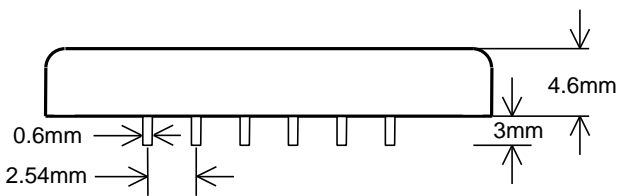

Figure 5 Side View of CWD-01-V2-D

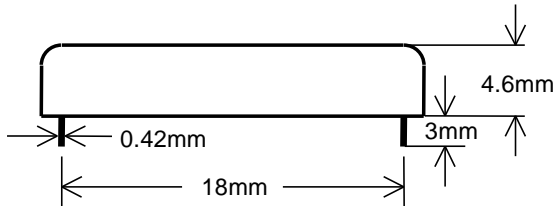

Figure 6 End View of CWD-01-V2-D

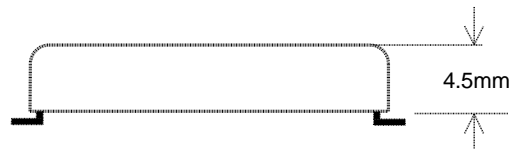

Figure 7 End View of CWD-01-V2-S

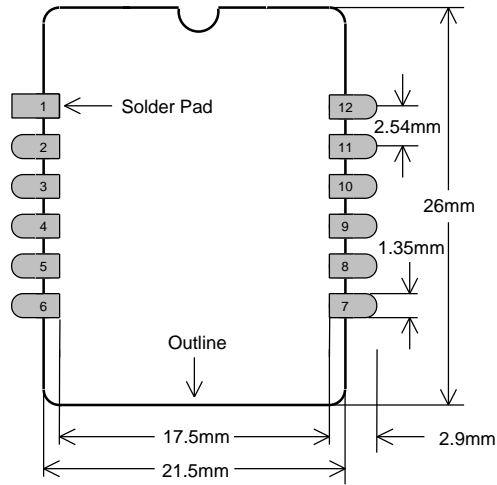

Figure 8 Recommended PCB footprint for surface mount package

Note: The Constant Current CW Laser Drivers come in two types of packages: surface mount and through hole. The surface mount package has to be soldered manually, not by reflow oven. The through hole package can be mounted in a socket, soldered manually, or by wave soldering machine. Package type is designated by suffixing D (through hole) or S (surface mount) to the part number.