

Incremental encoders

Mini series, with shaft

Resolution 5...2048 pulses

GI328



GI328 with shaft

Features

- Mini encoder with shaft $\varnothing 5$ mm
- Resolution max. 2048 ppr
- Housing $\varnothing 30$ mm
- High rotation speed max. 12000 rpm
- Operating temperature range -20...+85°C

Technical data - electrical ratings

Voltage supply	5 VDC ± 10 % 10...30 VDC
Reverse polarity protection	Yes (10...30 VDC)
Consumption w/o load	≤ 60 mA
Resolution (steps/turn)	5...2048
Reference signal	Zero pulse, width 90°
Sensing method	Optical
Output frequency	≤ 100 kHz
Output signals	A 90° B, N + inverted
Output circuit	Linedriver RS422 Push-pull short-circuit proof
Interference immunity	DIN EN 61000-6-2
Emitted interference	DIN EN 61000-6-4

Output signals

Clockwise rotating direction when looking at flange.

Output signal 5 VDC, linedriver

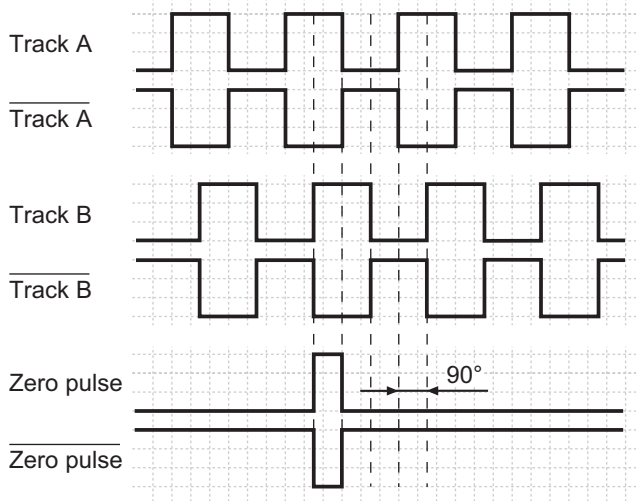

Technical data - mechanical design

Housing	$\varnothing 30$ mm
Shaft	$\varnothing 5$ mm
Flange	Synchro flange
Protection DIN EN 60529	IP 42 IP 65
Operating speed	≤ 6000 rpm IP 65 ≤ 12000 rpm IP 42
Admitted shaft load	≤ 10 N axial ≤ 10 N radial
Materials	Housing: polyamide black Flange: aluminium Shaft: stainless
Operating temperature	-20...+85 °C
Relative humidity	95 % non-condensing
Resistance	DIN EN 60068-2-6 Vibration 10 g, 16-200 Hz DIN EN 60068-2-27 Shock 50 g, 11 ms
Weight approx.	85 g
E-connection	Cable 1 m

Clockwise rotating direction when looking at flange.

Output signals 10...30 VDC, push-pull

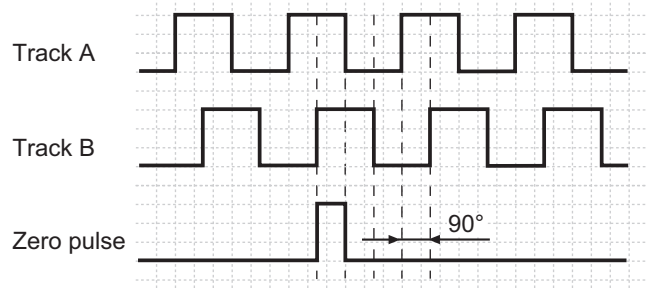

Incremental encoders

Mini series, with shaft
Resolution 5...2048 pulses

GI328

Part number

GI328.

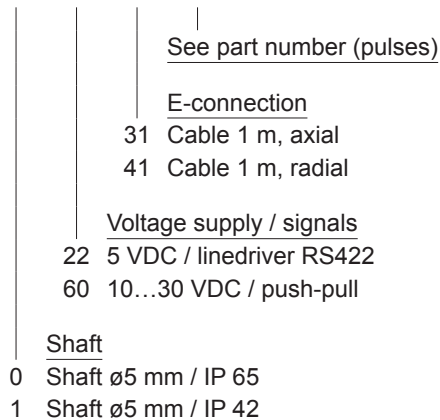

Part number (pulses)

49 (5)	06 (200)	15 (500)	29 (2048)
39 (50)	09 (250)	22 (1000)	
40 (60)	13 (360)	23 (1024)	
41 (100)	14 (400)	28 (2000)	

Other pulse numbers upon request.
Example: ordering key 23 = 1024 pulses

Terminal assignment

Linedriver

Core colour Assignment

brown UB

green Track A

red Track A inv.

yellow Track B

blue Track B inv.

pink Track N (zero pulse)

grey Track N inv. (zero pulse inv.)

white GND

Push-pull

Core colour Assignment

brown UB

green Track A

yellow Track B

pink Track N (zero pulse)

white GND

Please use cores twisted in pairs (for example track A / track A inv.) for extension cables of more than 10 m length.

Trigger level

Outputs

Linedriver RS422

Output level High >2.4 V (I = -20 mA)

Output level Low <0.4 V (I = 20 mA)

Load High <20 mA

Load Low <20 mA

Outputs

Push-pull circuit-proof

Output level High >UB -2.7 V (I = -10 mA)

Output level Low <0.2 V (I = 20 mA)

Load High <20 mA

Load Low <20 mA

Dimensions

