

Silicon PNP Power Transistors

2SB713

DESCRIPTION

- With TO-3PN package
- Wide area of safe operation
- Excellent good linearity of h_{FE}

APPLICATIONS

- For high power amplifier applications

PINNING

PIN	DESCRIPTION
1	Base
2	Collector;connected to mounting base
3	Emitter

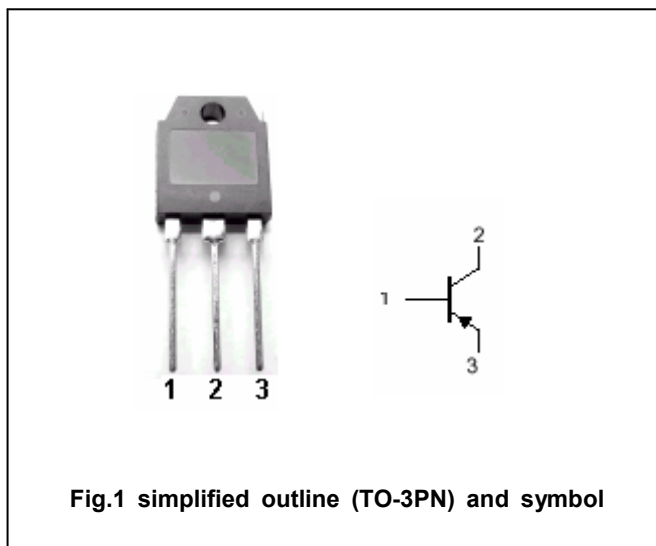

Fig.1 simplified outline (TO-3PN) and symbol

Absolute maximum ratings($T_c=25^\circ$)

SYMBOL	PARAMETER	CONDITIONS	VALUE	UNIT
V_{CBO}	Collector-base voltage	Open emitter	-200	V
V_{CEO}	Collector-emitter voltage	Open base	-140	V
V_{EBO}	Emitter-base voltage	Open collector	-5	V
I_C	Collector current (DC)		-9	A
I_{CP}	Collector current (Pulse)		-15	A
P_C	Collector power dissipation	$T_c=25^\circ$	100	W
T_j	Junction temperature		150	$^\circ$
T_{stg}	Storage temperature		-55~150	$^\circ$

Silicon PNP Power Transistors

2SB713

CHARACTERISTICS

T_j=25°C unless otherwise specified

SYMBOL	PARAMETER	CONDITIONS	MIN	TYP.	MAX	UNIT
V _{CEsat}	Collector-emitter saturation voltage	I _C =-7A; I _B =-0.7A			-2.0	V
V _{BE}	Base-emitter on voltage	I _C =-7A; V _{CE} =-5V			-1.8	V
I _{CBO}	Collector cut-off current	V _{CB} =-140V; I _E =0			-50	μA
I _{EBO}	Emitter cut-off current	V _{EB} =-3V; I _C =0			-50	μA
h _{FE-1}	DC current gain	I _C =-20mA; V _{CE} =-5V	20			
h _{FE-2}	DC current gain	I _C =-1A; V _{CE} =-5V	40		200	
h _{FE-3}	DC current gain	I _C =-7A; V _{CE} =-5V	15			
f _T	Transition frequency	I _C =-0.5A; V _{CE} =-5V		7		MHz
C _{OB}	Collector output capacitance	f=1MHz; V _{CB} =-10V		220		pF

◆ h_{FE-2} Classifications

R	Q	P
40-80	60-120	100-200

Silicon PNP Power Transistors

2SB713

PACKAGE OUTLINE

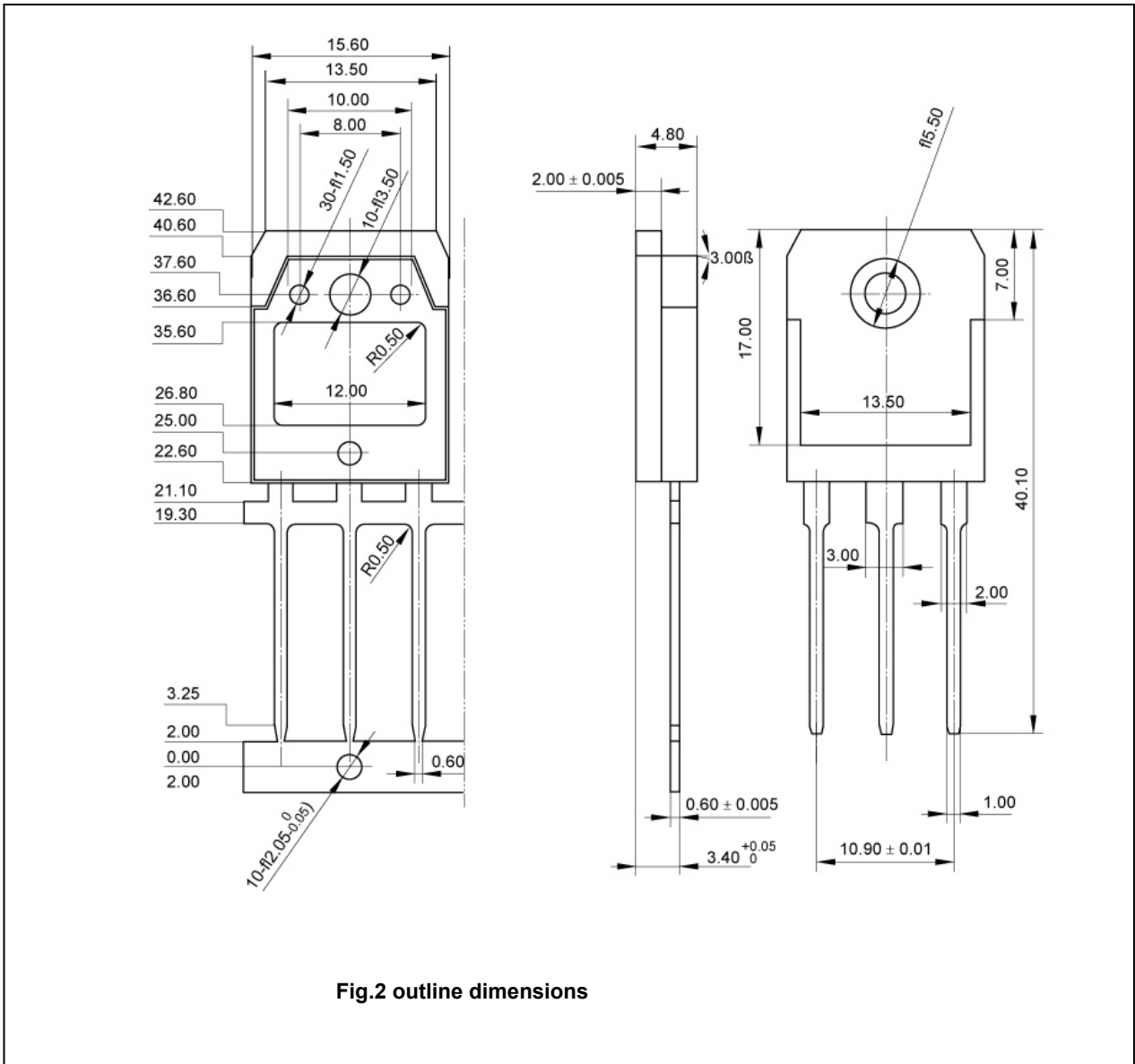

Fig.2 outline dimensions