

Silicon NPN Power Transistors

2SD350A

DESCRIPTION

- With TO-3 package
- High voltage ,high speed

APPLICATIONS

- For color TV horizontal deflection output applications

PINNING(see fig.2)

PIN	DESCRIPTION
1	Base
2	Emitter
3	Collector

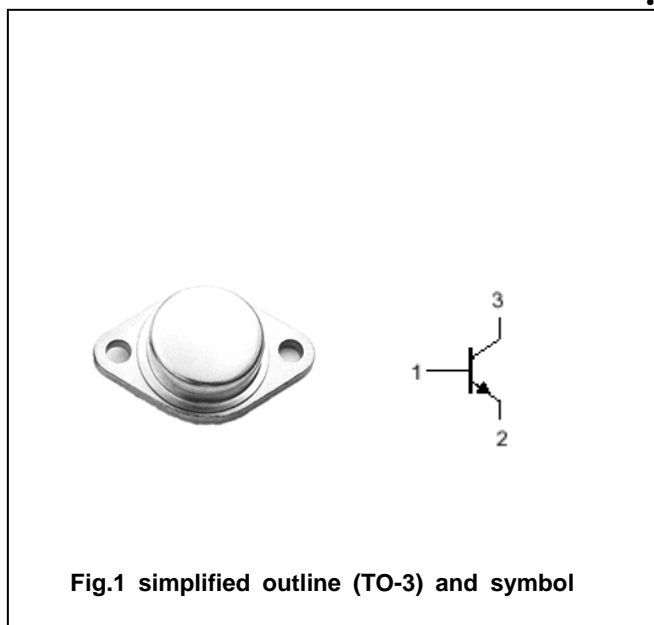
**Absolute maximum ratings(Ta=°C)**

SYMBOL	PARAMETER	CONDITIONS	VALUE	UNIT
V _{CBO}	Collector-base voltage	Open emitter	1500	V
V _{CEO}	Collector-emitter voltage	Open base	700	V
V _{EBO}	Emitter-base voltage	Open collector	5	V
I _C	Collector current		5	A
I _{CM}	Collector current-peak		7	A
P _T	Total power dissipation	T _C =90°C	22	W
T _j	Junction temperature		150	°C
T _{stg}	Storage temperature		-55~150	°C

Silicon NPN Power Transistors

2SD350A

CHARACTERISTICS

T_j=25°C unless otherwise specified

SYMBOL	PARAMETER	CONDITIONS	MIN	TYP.	MAX	UNIT
V _{CEO(SUS)}	Collector-emitter sustaining voltage	I _C =0.1A; I _B =0	700			V
V _{(BR)EBO}	Emitter-base breakdown voltage	I _E =10mA; I _C =0	5			V
V _{CEsat}	Collector-emitter saturation voltage	I _C =4.5 A; I _B =2A			1.0	V
V _{BEsat}	Base-emitter saturation voltage	I _C =4.5 A; I _B =2A			1.3	V
I _{CB0}	Collector cut-off current	V _{CB} =800V; I _E =0			10	μ A
h _{FE-1}	DC current gain	I _C =1A ; V _{CE} =5V	8			
h _{FE-2}	DC current gain	I _C =4A ; V _{CE} =10V	3			

PACKAGE OUTLINE

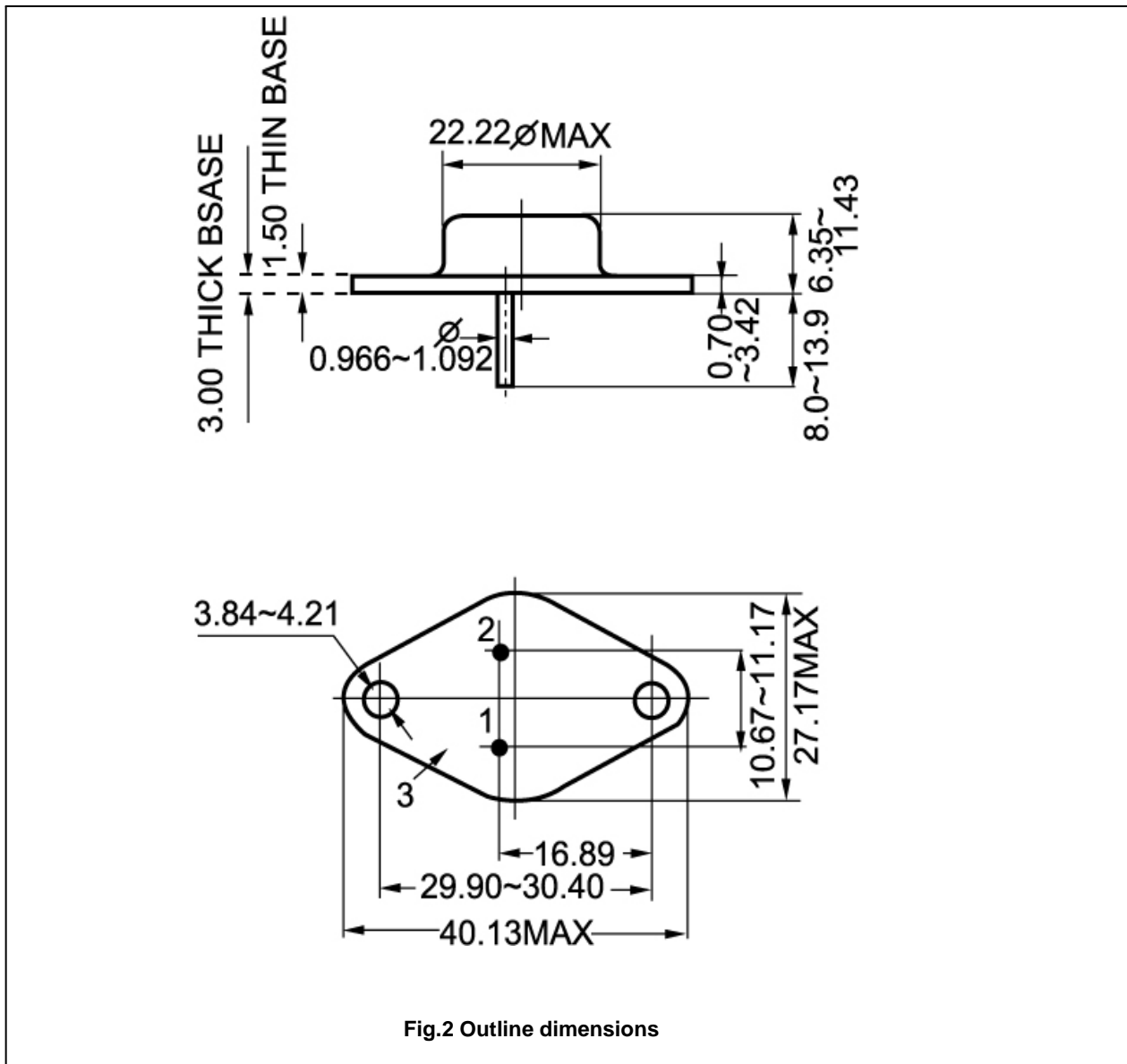

Fig.2 Outline dimensions