

Silicon PNP Power Transistors

2SB849A

DESCRIPTION

- With TO-3PFa package
- Complement to type 2SD1110A
- Wide area of safe operation

APPLICATIONS

- For use in low frequency power amplifier applications

PINNING

PIN	DESCRIPTION
1	Base
2	Collector
3	Emitter

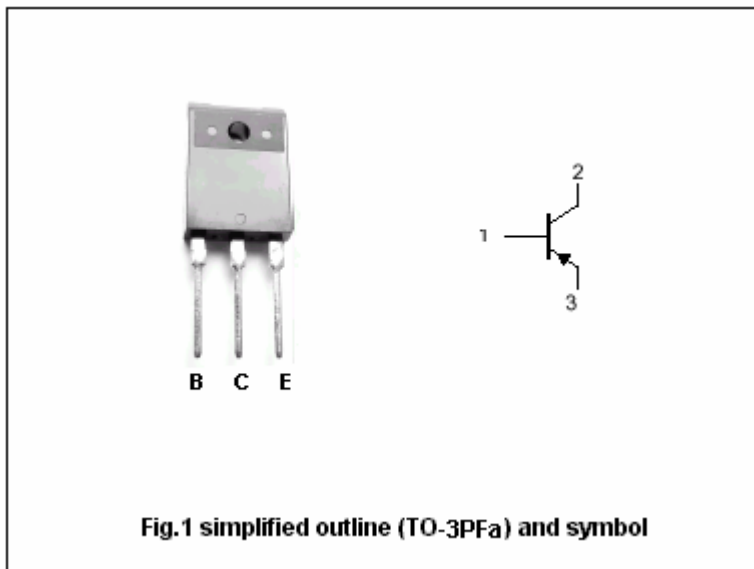

Absolute maximum ratings(Ta=25°C)

SYMBOL	PARAMETER	CONDITIONS	VALUE	UNIT
V _{CBO}	Collector-base voltage	Open emitter	-130	V
V _{CEO}	Collector-emitter voltage	Open base	-130	V
V _{EBO}	Emitter-base voltage	Open collector	-7	V
I _C	Collector current		-7	A
P _C	Collector power dissipation	T _C =25°C	80	W
T _j	Junction temperature		150	°C
T _{stg}	Storage temperature		-55~150	°C

Silicon PNP Power Transistors

2SB849A

CHARACTERISTICS

T_j=25 °C unless otherwise specified

SYMBOL	PARAMETER	CONDITIONS	MIN	TYP.	MAX	UNIT
V _{(BR)CEO}	Collector-emitter breakdown voltage	I _C =-10mA ; I _B =0	-130			V
V _{CEsat}	Collector-emitter saturation voltage	I _C =-5A ; I _B =-0.5A			-2.0	V
V _{BEsat}	Base-emitter saturation voltage	I _C =-5A ; I _B =-0.5A			-2.0	V
I _{CBO}	Collector cut-off current	V _{CB} =-120V; I _E =0			-50	μA
I _{EBO}	Emitter cut-off current	V _{EB} =-6V; I _C =0			-50	μA
h _{FE-1}	DC current gain	I _C =-20mA ; V _{CE} =-5V	20			
h _{FE-2}	DC current gain	I _C =-1A ; V _{CE} =-5V	40		200	
C _{OB}	Output capacitance	I _E =0 ; V _{CB} =-10V; f=1MHz		340		pF
f _T	Transition frequency	I _C =-0.2A ; V _{CE} =-5V		14		MHz

Silicon PNP Power Transistors

2SB849A

PACKAGE OUTLINE

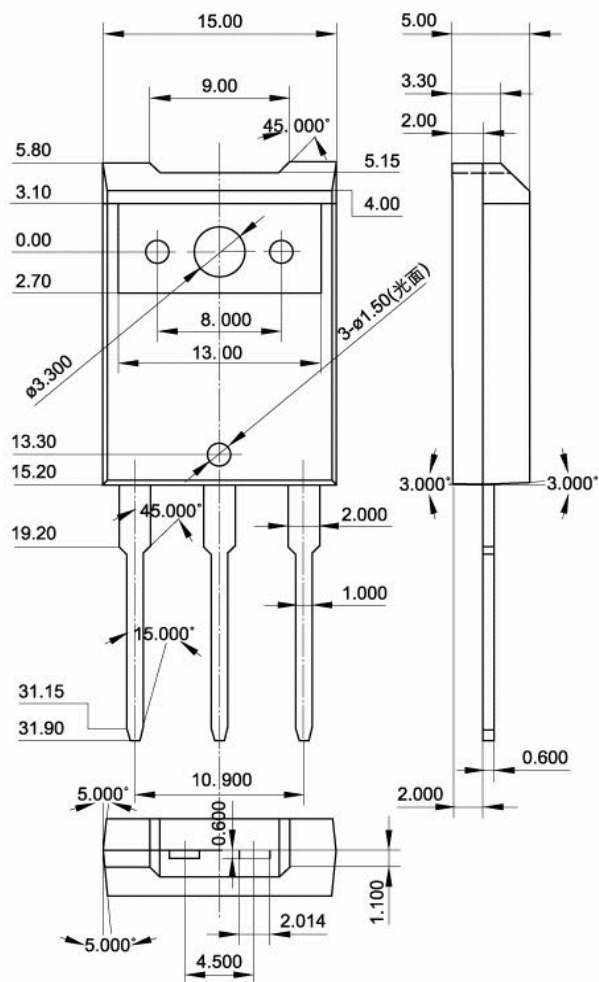

Fig.2 Outline dimensions (unindicated tolerance:±0.30mm)