

FEATURES

- 2 Operation Modes (Proximity and Barrier)
- External Synchronisation in the Barrier Mode
- Ambient Light Rejection
- Adjustable Threshold and Hysteresis
- Normally Open and Normally Closed Outputs
- Driver for PNP Output Transistors with Short Circuit Protection
- LED Output 8 mA (Source and Sink)
- Adjustable Detection Distance and Hysteresis
- Dirt Indication in the Barrier Mode
- Internal Zener Diode for Voltage Stabilisation (optional)
- Maximum Supply Voltage only Depending on External Elements

GENERAL DESCRIPTION

The AM 336 is a bipolar monolithic integrated circuit designed for optical detection applications.

By adding an external photodiode, an IR LED, two PNP power transistors and a minimum of other parts, the AM 336 will be a complete optoelectronic interface (proximity and barrier) for a reflective optical proximity switch or for a light barrier with external synchronisation.

APPLICATIONS

- Miniaturised One Way Light Barrier
- Miniaturised Reflection Light Barrier
- Frame Light Barrier

BLOCK DIAGRAM

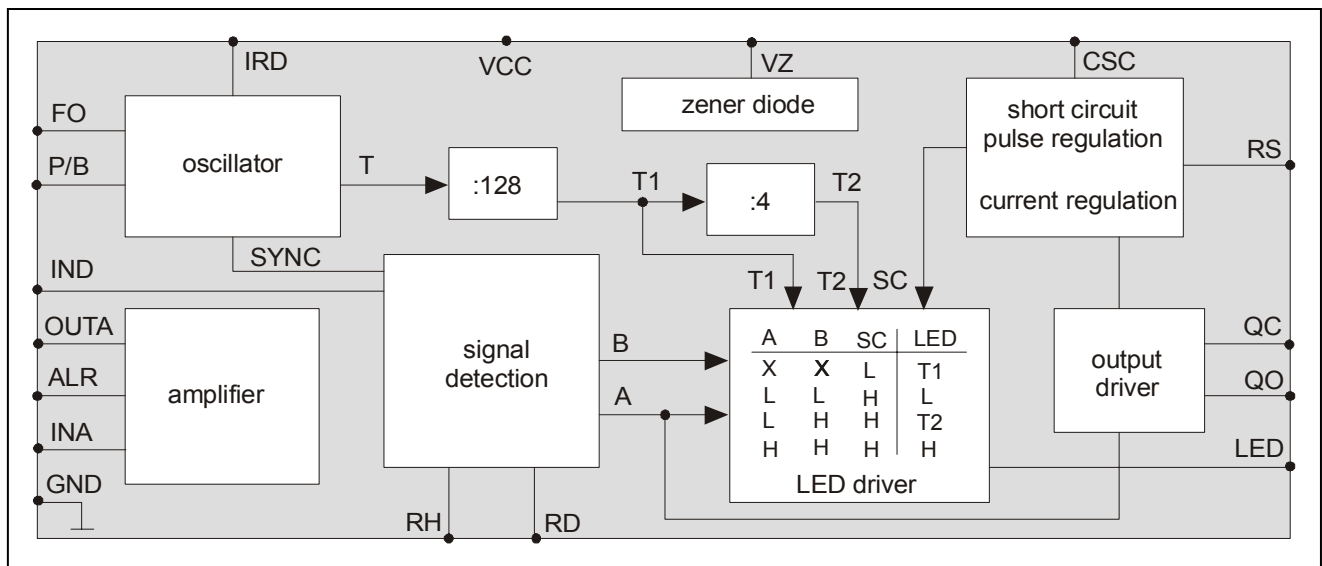

Figure 1: Block diagram of AM336

ABSOLUTE MAXIMUM RATINGS

DC Supply Voltage V_{CC}	6,7V
Current Zener Diode I_{ZD}	10mA
Junction Temperature T_J	150°C
Storage Temperature Range T_{st}	- 25...125°C
Operating Temperature Range T_{amb}	0...85°C

ELECTRICAL SPECIFICATIONS

$T_{amb} = 25^\circ\text{C}$, $V_{CC} = 6.5\text{V}$, $R_O = 560\text{k}\Omega$, $C_O = 4.7\text{nF}$ (unless otherwise noted)

Parameter	Symbol	Conditions	Min.	Typ.	Max.	Unit
Supply Voltage	V_{CC}		5.5	6.5	6.7	V
Supply Current	I_{CC}		6.0	8.0		mA
Oscillator						
Output current (low)	$I_{IRD\ low}$	$V_{IRD} = 0.8\text{V}$			8.0	mA
Output current (high)	$I_{IRD\ high}$	$V_{IRD} = 6.5\text{V}$		380		μA
Discharging resistor	R_E	internal	4.4	5.9	7.4	k Ω
Proximity (P/B = low):						
Emission pulse width	T_{IRD}	$0.4 \times R_E \times C_O$		11		μs
Emission frequency	f_{OP}	$2.5 / (R_O \times C_O)$, $R_O \gg R_E$		950		Hz
Barrier (P/B = high):						
Frequency oscillator freerun	f_{OB}	$1.25 / (R_O \times C_O)$, $R_O \gg R_E$		475		Hz
Synchronisation pulse width	T_{SYNC}	$0.6 \times R_E \times C_O$, $R_O \gg R_E$	25			μs
Synchronisation frequency	f_{SYNC}	$1.2 \times f_{OB} < f_{SYNC} < f_{OP}$	600		900	Hz
Amplifier						
Low frequency impedance	R_B	internal	8	10	12.5	k Ω
Signal detection stage						
Threshold comparator A	V_{TA}	$R_D = 30\text{k}\Omega$		900		mV
	V_{TA}	$R_D = 180\text{k}\Omega$		25		mV
Threshold comparator B	V_{TB}	$R_D = 30\text{k}\Omega$		1350		mV
	V_{TB}	$R_D = 180\text{k}\Omega$		25		mV
Hysteresis comparator A	V_{HA}	$R_H = 200\text{k}\Omega$, $R_D = 30\text{k}\Omega$		45		mV
	V_{HA}	$R_H = 200\text{k}\Omega$, $R_D = 180\text{k}\Omega$		2		mV
Filter resistor	R_{IN}	internal	15	19	24	k Ω

Parameter	Symbol	Conditions	Min.	Typ.	Max.	Unit
Output stages						
Output current (on)	$I_{Q\ on}$	$U_Q = V_{CC} - 1.5V$		1.2		mA
Output current (off)	$I_{Q\ off}$	$U_Q = V_{CC} - 1.5V$		-0.7		mA
Current limitation threshold	VS	internal		440		mV
LED driver ($R_o = 580k, C_o \approx 4.7nF$)						
LED current (low)	$I_{LED\ low}$	at $V_{LED} = 0.8V$			8.0	mA
LED current (high)	$I_{LED\ high}$	at $V_{LED} = V_{CC} - 1.8V$			-8.0	mA
Short circuit frequency	T1	$f_{OP} / 128$		7.4		Hz
		$f_{SYNC} / 128, f_{SYNC} = 768Hz$		6.0		Hz
IND window frequency	T2	$f_{OP} / 512$		1.8		Hz
Zener diode						
Zener voltage	VZ	$I_Z = 100\mu A$	6.7	6.9	7.1	V

Table 1: Electrical Specifications

BOUNDARY CONDITIONS

Parameter	Symbol	Min.	Max.	Unit
Oscillator pull up	R_{TD}	0.7	10	$k\Omega$
Amplifier DC input current	I_{INA}	0	200	μA
Distance resistor	R_D	30	200	$k\Omega$
Hysteresis resistor	R_H	22		$k\Omega$

Table 2: Boundary Conditions

FUNCTIONAL DIAGRAM

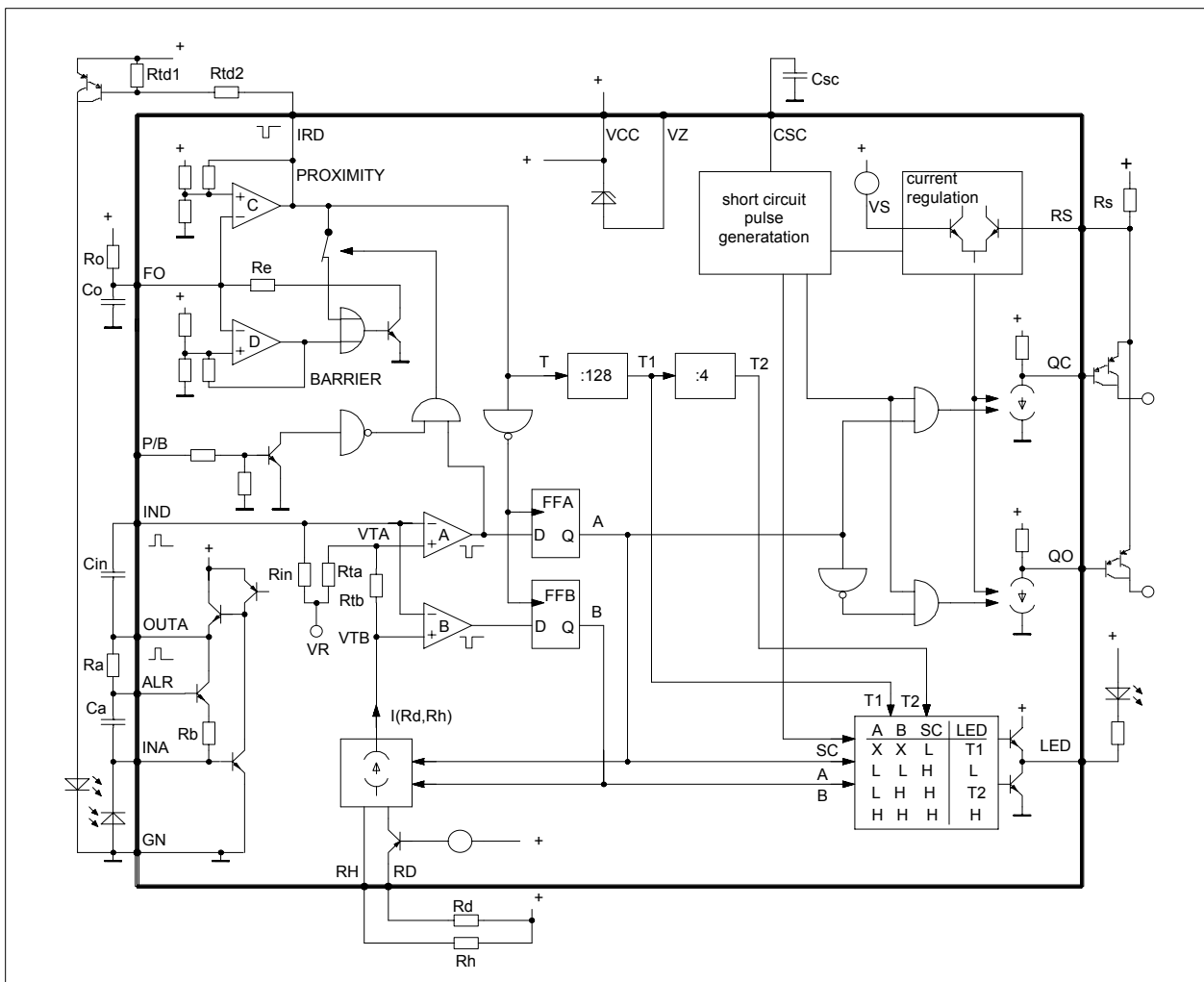

Figure 1: Functional circuit

FUNCTIONAL DESCRIPTION

GENERAL:

The AM 336 is designed for proximity and barrier applications with the possibility of external synchronisation (mode selection by Pin P/B).

The circuit contains different functional modules.

Oscillator:

Oscillator thresholds refer to $VCC/2$, driver output for IR-LED, emitting-pulse length and duty cycle adjusted by external components RO and CO.

Amplifier:

Current to voltage converter, ambient light rejection.

Signal detection stage:

Triggered window comparator, trigger at the end of emitting-pulse, "one pulse system" (no signal filtering).

Output stages:

Two antivalent outputs for external PNP Darlington transistors, short circuit protection with external resistor, periodically shutdown with a duty cycle of 1%.

LED driver:

Push-pull output, indicates state of the output stages.

Z-diode:

For supply voltage stabilisation with an external transistor, so the maximum system operating voltage depends only on external elements (wide voltage range possible).

Signal emission:

Emission pulses for applications with internal synchronisation are generated by the oscillator.

Signal detection:

Photodiode current at pin INA is converted by the amplifier. Amplifier output (pin OUTA) is connected via a capacitor (CIN) to the signal detection input (pin IND). The signal is applied to the comparators A and B. At the end of the emitting pulse the output state of the comparators is taken over to the flip-flop A and B. Flip-flop A controls the output stages QO and QC.

External synchronisation:

A valid received light pulse synchronises the at low frequency running oscillator, pulse length and period have to be appropriate.

OSCILLATOR:

The frequency f_0 of the on-chip oscillator is set by external resistor R_O and capacitor C_O (pin FO).

C_O is charged via R_O and discharged via R_E ($R_O \gg R_E$) controlled by internal thresholds. The oscillator frequency varies with the two operating modes by switching oscillator thresholds.

IRD drives an IR-LED via an external PNP transistor. If no external transistor is used, a pull-up resistor has to be connected.

Proximity mode (P/B = low):

When the ramp at pin FO reaches the upper threshold of comparator C, an emission pulse at pin IRD and the discharging of capacitor C_O is triggered. This negative pulse is determined by the discharging time of capacitor C_O . Comparator D is not affected (output stays at high level) because its thresholds are closer to the limits of the operating voltage than the thresholds of comparator C.

Barrier mode (P/B = high):

By setting the Pin A/B = high, the comparator C is disabled and the oscillator runs by means of comparator D at a lower frequency. If there is no light pulse or it is too low, the capacitor C_O is discharged when the upper threshold of comparator D is reached. A valid received light pulse starts the discharge of C_O earlier thus synchronising the oscillator. The synchronisation frequency has as an upper (proximity-frequency: f_{OP}) and a lower (barrier-frequency: $1.2 \times f_{OB}$) limit. If the

frequency it to high the signal detection is not triggered. In case of a too low frequency a pulsed signal could occur at the output stages.

Connection pins: FO, IRD, P/B

AMPLIFIER:

The input stage for the photo current is a transimpedance–amplifier. His impedance depends on the input frequency to reject ambient light.

The input current, coming from pin INA, appears multiplied by the impedance between INA and OUTA at pin OUTA. For low frequencies this impedance is approximately R_B (internal resistor) and for high frequencies R_A (external resistor).

Connection pins: INA, OUTA, ALR.

SIGNAL DETECTION STAGE:

The signal of the input stage is connected via a high–pass filter (C_{IN} between OUTA and IND, R_{IN} internal) to the inputs of comparator A and B (window comparator). The threshold voltages V_{TA} and V_{TB} and the hysteresis voltages V_{HA} and V_{HB} are generated by a constant current across the resistors R_{TA} and R_{TB} ($R_{TA} = 2 \times R_{TB}$). The hysteresis is switched by the output signals of the D–flip–flops. Threshold and hysteresis levels are determined by external resistors (R_D R_H) and temperature compensated by an internal voltage reference (VR). The resistors have to be located as

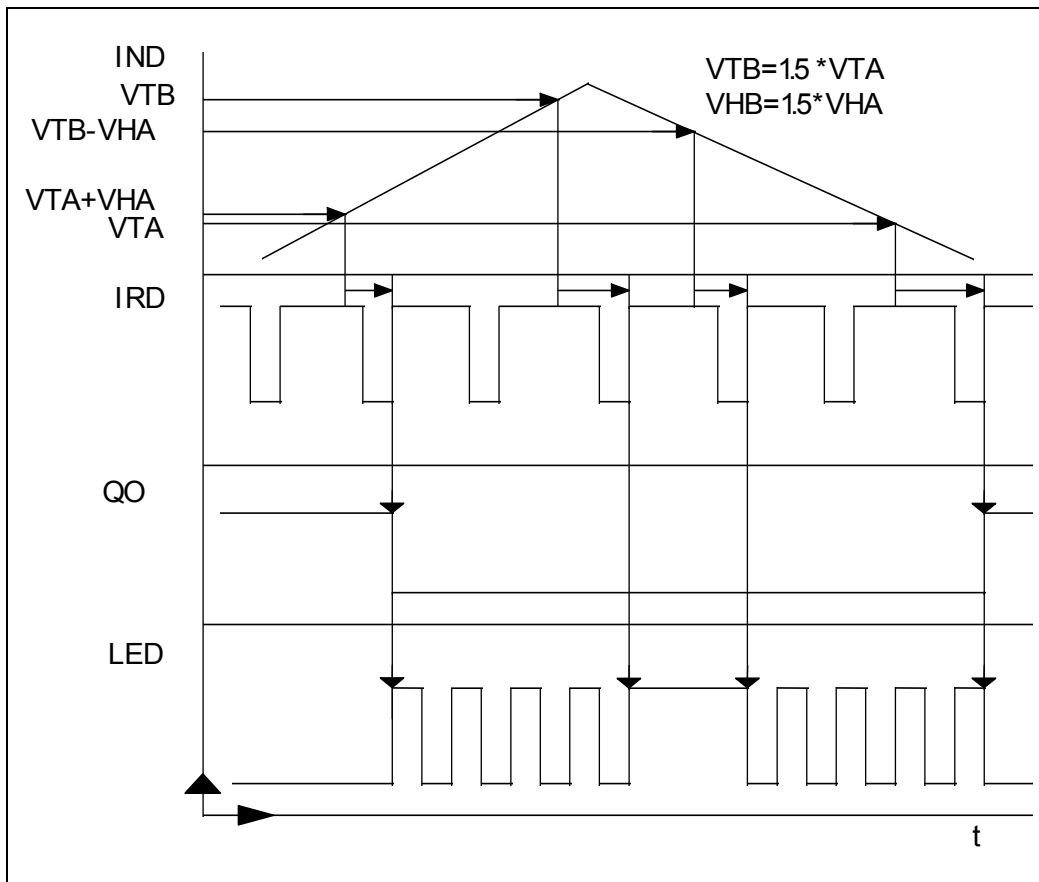

Figure 2: Functional diagram

close as possible to the pin to prevent noise. Also, in case of high emission-currents, blocking capacitors against V_{CC} are useful.

The comparator signals are taken over into the flip-flops with the positive slope of the IRD-signal.

Connections pins: IND, RD, RH

OUTPUT STAGES:

There are two antivalent output drivers for external PNP Darlington transistors with a current limitation and periodical shut down in case of overload (short circuit protection).

The output signal of the internal flip-flop A (depending on V_{TA}) controls the output drivers. They consist of current sources which are attached to an internal pull-up resistor. The voltage drop at the resistor R_S , produced by the loading current, is compared with an internal voltage and is used to limit the loading current. When limitation occurs, the external capacitor C_{SC} is discharged and by reaching the internal threshold both output drivers are switched off. After loading the capacitor C_{SC} is discharged and by reaching the threshold both output drivers are switched off. After charging the capacitor C_{SC} to the upper threshold the output stages are enabled again.

Unused outputs have to be attached to V_{CC} . External PNP Darlington transistors have to be used so that the necessary potential ($V_{CC} - 2 \times V_{BE}$) is available at the outputs in order to limit the loading current.

Connection pins : QO, QC, RS, CSC

LED DRIVER:

The push-pull driver for the LED indicates the different ranges of the window-comparator or short circuit of the output stages.

Following conditions are possible:

A	B	SC	LED	
X	X	L	T_1	short circuit, input voltage at IND has no effect
L	L	H	L	input voltage at IND is higher than V_{TA} and V_{TB}
L	H	H	T_2	input voltage is higher than V_{TA} , but smaller than V_{TB}
H	H	H	H	input voltage is smaller than V_{TA} and V_{TB}

Table 3: LED indications

Blinking frequencies for LED:

T_1 : oscillator frequency for divided by 128

T_2 : oscillator frequency for divided by 512

Connection pin: LED

PADOUT

PAD	NAME	DESIGNATION
1	LED	LED driver output
2	RD	Detection distance adjustment
3	VZ	Zener diode
4	RS	Sense input for current regulation and short circuit
5	QO	Output for PNP–Darlington, normally open
6	QC	Output for PNP–Darlington, normally close
7	VCC	Supply voltage
8	RH	Hysteresis of the detection distance
9	FO	Oscillator input
10	IND	Detection input
11	GND	Ground
12	INA	Amplifier input
13	ALR	Ambient light rejection
14	OUTA	Amplifier output
15	IRD	Output for PNP, IR–LED driver
16	P/B	Mode selection: low = proximity, high = barrier
17	CSC	Short circuit capacitor

Table 4: Padout

AVAILABLE PINOUTS

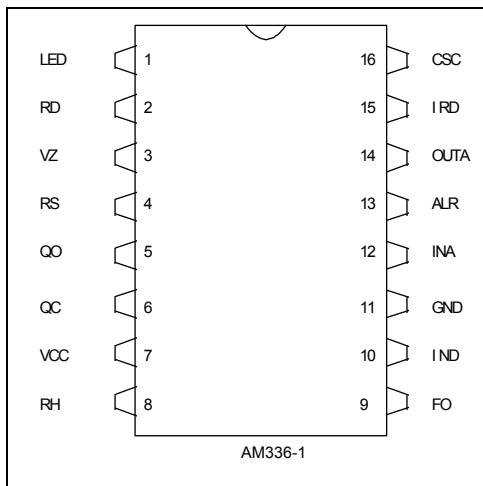

Figure 3: Internal synchronisation only
[Z-Diode (pin VZ) available]

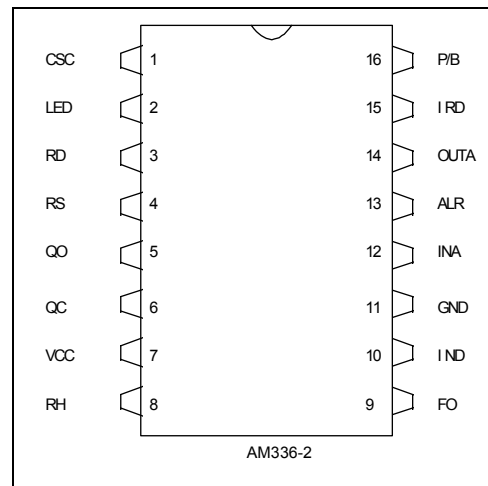

Figure 4: Internal/external synchronisation
[mode selection (pin P/B) available]

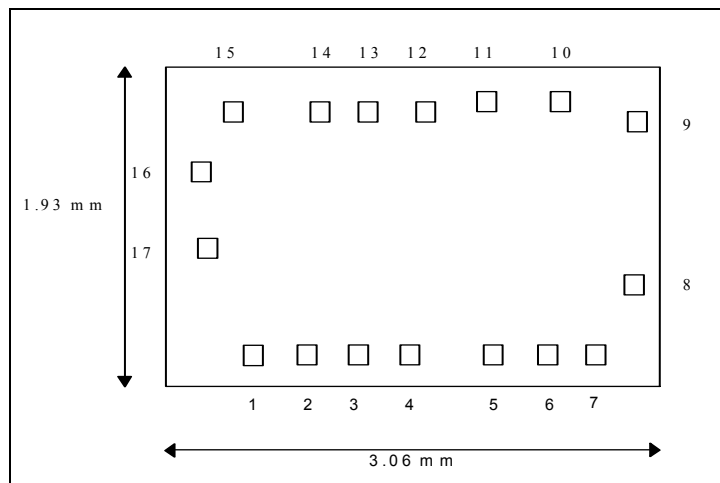

Figure 5: Chip Dimensions

DELIVERY

- SO16-packaging (standard)
- DIL16-package only for engineering samples
- dice on 5" blue foil

APPLICATION EXAMPLES

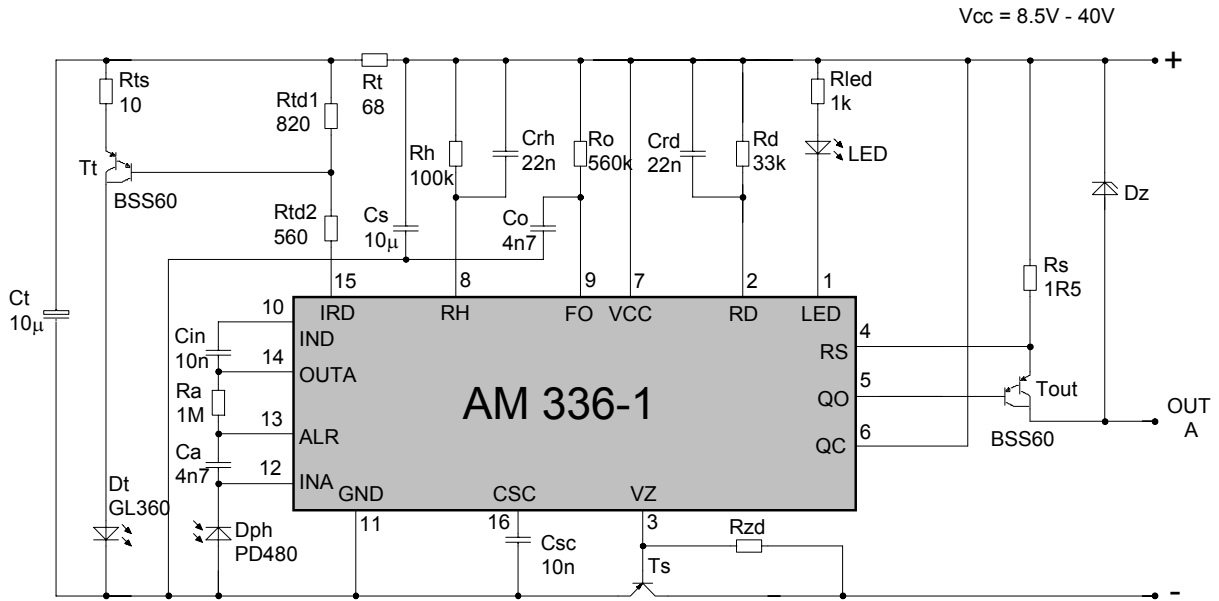

Figure 7: Proximity application

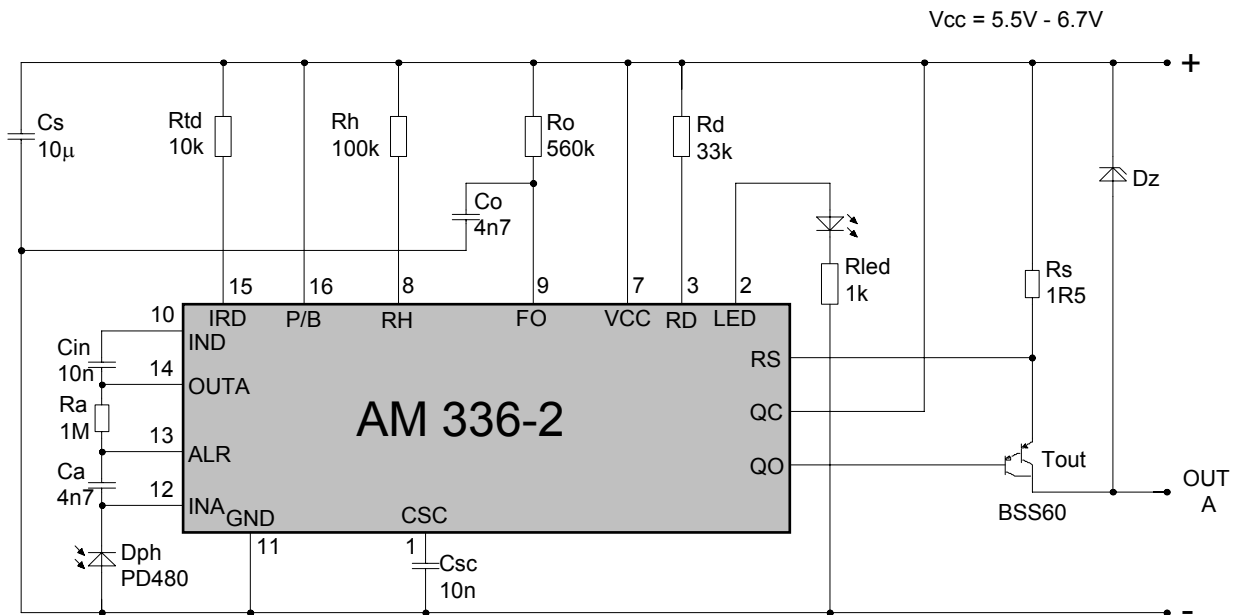

Figure 8: Barrier application (without voltage stabilisation)

TYPICAL VALUES

Symbol	Description	Value	Unit
D _T	SFH40x; SFH41x; SFH48x; Siemens or GL 360; Sharp		
D _{PH}	SHF21x ; SFH22x ; Siemens or PD 480; Sharp		
C _T , C _S	typical; depending on noise caused by emission current	10	μF
R _T		68	Ω
R _{TS}		10	Ω
R _{TD}		10	kΩ
R _{TD1}		820	Ω
R _{TD2}		560	Ω
R _O		560	kΩ
C _O		4.7	nF
C _A		4.7	nF
C _{IN}		10	nF
C _{SC}		10	nF
C _{th} , C _{td}	Blocking Capacitor against Perturbation, Noise 10–100nF		
R _{LED}		1	kΩ
R _{ZD}	depending on used supply voltage, I _{ZD} max. = 10 mA	4.7	kΩ
R _S		1.5	kΩ
T _t	BST60; Philips		
T _{OUT}	BST60; Philips		
T _S	BCX51–16; Philips		
D _Z	Zy47: ITT		
D _{ZD}	ZPD 6.8; ITT		
R _D , R _H	Threshold approximation: $VT_A [V] = 800 / (R_d [k\Omega])^2$ $VT_B = 1.5 VT_A$ $VH_A [V] = (10 \times VT_A [V] / R_h [k\Omega])$ $VH_B = 1.5 \times VH_A$		
R _A	depends on photodiode–pulse–current, R _A [min] = VT _A / I _{pulse} [max]		