

Features

- * Ultra brightness..
- * Versatile mounting on p.c. board or panel.
- * I.C. compatible/low current requirement.
- * Reliable and rugged.

Package Dimensions

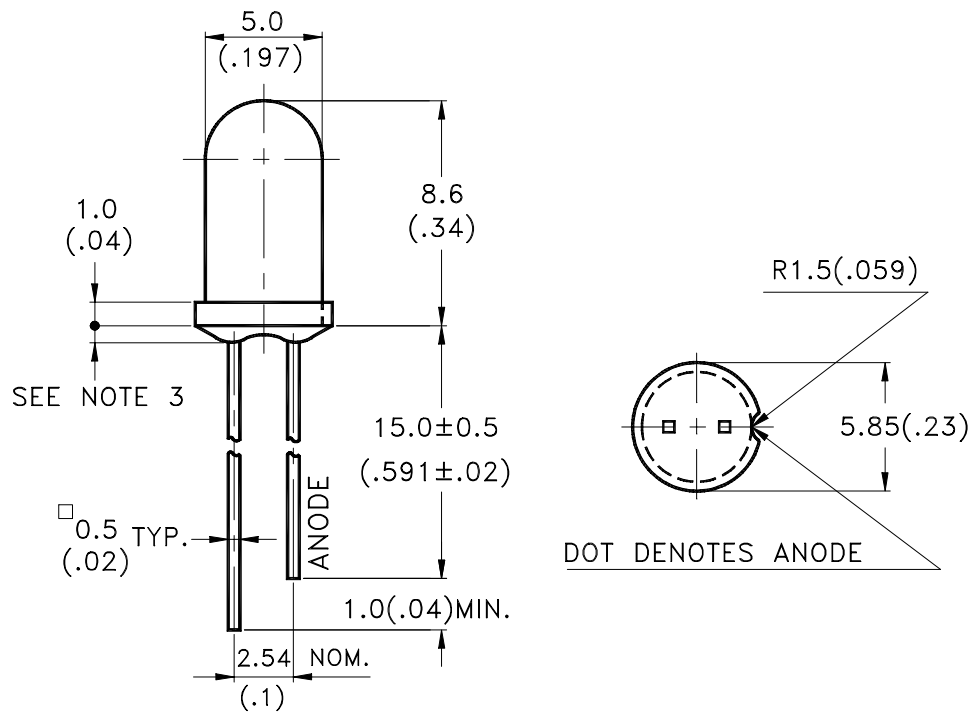

Part No.	Lens	Source Color
LTL-307CKAP	Water Clear	AlGaAs Red

Notes:

1. All dimensions are in millimeters (inches).
2. Tolerance is $\pm 0.25\text{mm}(.010\text{'})$ unless otherwise noted.
3. Protruded resin under flange is 1.0mm(.04") max.
4. Lead spacing is measured where the leads emerge from the package.
5. Specifications are subject to change without notice.



Absolute Maximum Ratings at TA=25°C

Parameter	Maximum Rating	Unit
Power Dissipation	100	mW
Peak Forward Current (1/10 Duty Cycle, 0.1ms Pulse Width)	200	mA
Continuous Forward Current	40	mA
Derating Linear From 50°C	0.5	mA/°C
Reverse Voltage	4	V
Operating Temperature Range	-40°C to + 100°C	
Storage Temperature Range	-55°C to + 100°C	
Lead Soldering Temperature [1.6mm(.063") From Body]	260°C for 5 Seconds	

Electrical / Optical Characteristics at TA=25°C

Parameter	Symbol		Min.	Typ.	Max.	Unit	Test Condition
Luminous Intensity	Iv	NP	100	220	360	mcd	IF = 20mA Note 1,4, 6
		PQ	100				
			180				
Viewing Angle	2 θ 1/2			35		deg	Note 2 (Fig.6)
Peak Emission Wavelength	λ P			660		nm	Measurement @Peak (Fig.1)
Dominant Wavelength	λ d			638		nm	Note 3
Spectral Line Half-Width	Δ λ			20		nm	
Forward Voltage	VF			1.8	2.4	V	IF = 20mA
Reverse Current	IR				100	μ A	VR = 4V
Capacitance	C			30		pF	VF = 0 , f = 1MHz

- Note: 1. Luminous intensity is measured with a light sensor and filter combination that approximates the CIE (Commission International De L'Eclairage) eye-response curve.
2. θ 1/2 is the off-axis angle at which the luminous intensity is half the axial luminous intensity.
3. The dominant wavelength, λ d is derived from the CIE chromaticity diagram and represents the single wavelength which defines the color of the device.
4. The Iv guarantee should be added ±15%.
5. Iv classification code is marked on each packing bag.
6. "N" class represents Iv min.= 100 mcd and max.= 200 mcd.
 "P" class represents Iv min.= 180 mcd and max.= 360 mcd.
 "Q" class represents Iv min.= 320 mcd and max.= 640 mcd.

Typical Electrical / Optical Characteristics Curves

(25°C Ambient Temperature Unless Otherwise Noted)

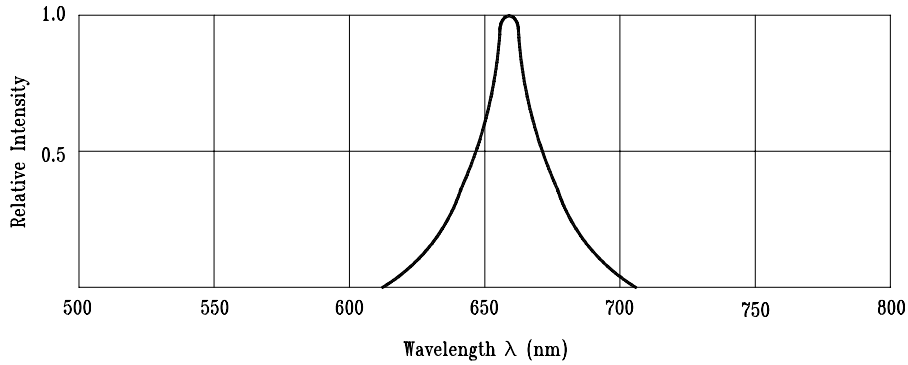

Fig.1 Relative Intensity vs. Wavelength

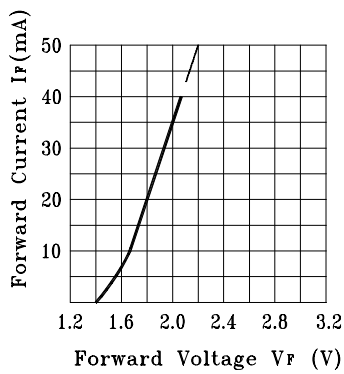

Fig.2 Forward Current vs. Forward Voltage

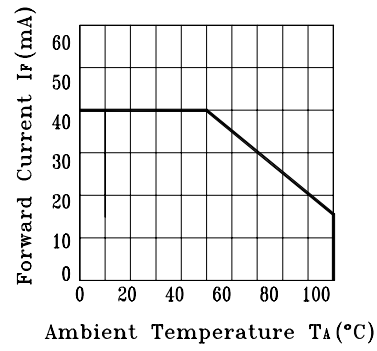

Fig.3 Forward Current Derating Curve

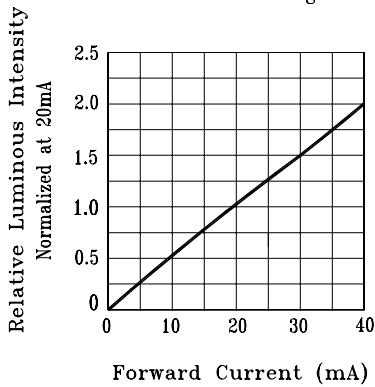

Fig.4 Relative Luminous Intensity vs. Forward Current

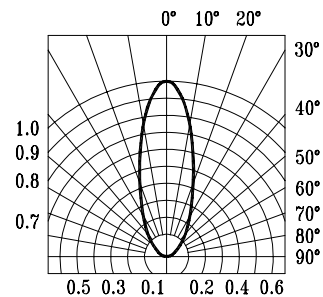

Fig.5 Spatial Distribution