

High-Speed Switching Applications

2SC4522

■ Features

- Large current capacity.
- Low collector-to-emitter saturation voltage.
- Fast switching speed.

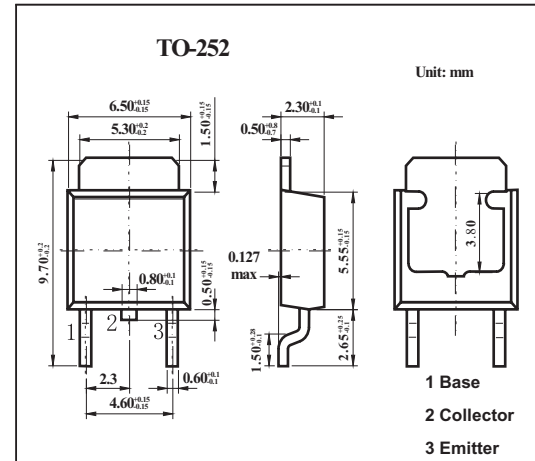

■ Absolute Maximum Ratings Ta = 25°C

Parameter	Symbol	Rating	Unit
Collector-base voltage	V _{CB0}	60	V
Collector-emitter voltage	V _{CEO}	45	V
Emitter-base voltage	V _{EBO}	5	V
Collector current	I _C	5	A
Collector current (pulse)	I _{CP}	8	A
Collector dissipation *	P _C	1	W
Junction temperature	T _J	150	°C
Storage temperature	T _{stg}	-55 to +150	°C

2SC4522

■ Electrical Characteristics Ta = 25°C

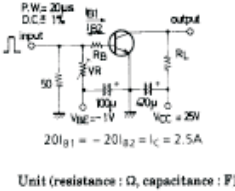
Parameter	Symbol	Testconditions	Min	Typ	Max	Unit	
Collector cutoff current	ICBO	V _{CB} = 45V, I _E =0			1	μA	
Emitter cutoff current	IEBO	V _{EB} = 2V, I _C =0			10	μA	
DC current gain	hFE	V _{CE} = 2V, I _C = 500mA	100		400		
		V _{CE} = 2V, I _C = 5A	40				
Gain bandwidth product	f _T	V _{CE} = 2V, I _C = 500mA		300		MHz	
Output capacitance	C _{ob}	V _{CB} = 10V, f = 1.0MHz		40		pF	
Collector-emitter saturation voltage	V _{CE(sat)}	I _C = 2.5A, I _B = 125mA		0.25	0.7	V	
Base-emitter saturation voltage	V _{BE(sat)}	I _C = 2.5A, I _B = 125mA		0.95	1.3	V	
Collector-base breakdown voltage	V _{(BR)CBO}	I _C = 100μA, I _E = 0	60			V	
Collector-emitter breakdown voltage	V _{(BR)CEO}	I _C = 1mA, R _{BE} = ∞	45			V	
Emitter-base breakdown voltage	V _{(BR)EBO}	I _E = 100μA, I _C = 0	5			V	
Turn-on time	t _{on}	 <p>Unit (resistance : Ω, capacitance : pF)</p>		50	100	ns	
Storage time	t _{stg}				150	270	ns
Fall time	t _f				180	350	ns

■ hFE Classification

Rank	R	S	T
hFE	100~200	140~280	200~400